

State of California
AIR RESOURCES BOARD

EXECUTIVE ORDER D-108
Relating to Exemptions under Section 27156
of the Vehicle Code

JAN 11 1981

THE MILEAGE CLINIC
THE BUBBLIZER VAPOR INJECTOR

Pursuant to the authority vested in the Air Resources Board by Section 27156 of the Vehicle Code; and

Pursuant to the authority vested in the undersigned by Sections 39515 and 39516 of the Health and Safety Code and Executive Order G-45-5;

IT IS ORDERED AND RESOLVED: That the installation of the Bubblizer Vapor Injector manufactured by The Mileage Clinic of Clearlake Highlands California has been found not to reduce the effectiveness of required motor vehicle pollution control devices and, therefore, is exempt from the prohibitions of Section 27156 of the Vehicle Code for installation on 1980 and older vehicles without closed loop feedback fuel systems.

This Executive Order is valid provided that installation instructions for this device will not recommend tuning the vehicle to specifications different from those submitted by the device manufacturer.

Changes made to the design or operating conditions of the device, as exempted by the Air Resources Board, that adversely affect the performance of a vehicle's pollution control system shall invalidate this Executive Order.

Marketing of this device using an identification other than that shown in this Executive Order or marketing of this device for an application other than those listed in this Executive Order shall be prohibited unless prior approval is obtained from the Air Resources Board. Exemption of a kit shall not be construed as an exemption to sell, offer for sale or advertise any component of a kit as an individual device.

This Executive Order does not constitute any opinion as to the effect that the use of this device may have on any warranty either expressed or implied by the vehicle manufacturer.

THIS EXECUTIVE ORDER DOES NOT CONSTITUTE A CERTIFICATION, ACCREDITATION, APPROVAL, OR ANY OTHER TYPE OF ENDORSEMENT BY THE AIR RESOURCES BOARD OF ANY CLAIMS OF THE APPLICANT CONCERNING ANTI-POLLUTION BENEFITS OR ANY ALLEGED BENEFITS OF THE BUBBLIZER.

No claim of any kind, such as "Approved by Air Resources Board" may be made with respect to the action taken herein in any advertising or other oral or written communication.

Section 17500 of the Business and Professions Code makes untrue or misleading advertising unlawful, and Section 17534 makes violation punishable as a misdemeanor.

Section 43644 of the Health and Safety Code provides as follows:

"43644. (a) No person shall install, sell, offer for sale, or advertise, or, except in an application to the state board for certification of a device, represent, any device as a motor vehicle pollution control device for use on any used motor vehicle unless that device has been certified by the state board. No person shall sell, offer for sale, advertise, or represent any motor vehicle pollution control device as a certified device which, in fact, is not a certified device. Any violation of this subdivision is a misdemeanor."

Any apparent violation of the conditions of this Executive Order will be submitted to the Attorney General of California for such action as he deems advisable.

Executed at El Monte, California, this 28th day of January, 1981.

K. D. Drachand
K. D. Drachand, Chief
Mobile Source Control Division

State of California
AIR RESOURCES BOARD

Staff Report

Evaluation of Bubblizer Vapor Injector System in Accordance with
Section 2222, Title 13 of the California Administration Code

I. INTRODUCTION

The Mileage Clinic Inc., P. O. Box 672 Clearlake Highlands, California has applied for an exemption from the prohibitions of Section 27156 of the California Vehicle Code for an add-on device known as the "Bubblizer Vapor Injection System."

II. DEVICE DESCRIPTION

The Bubblizer is a water vapor injection device. It is designed to allow a predetermined amount of air to pass through an air diffuser which is located near the bottom of a water container. The diffuser is said to produce many small air bubbles enabling more vapor to be mixed with the air. The vapor is then drawn into the carburetor and intake manifold through check valves and connecting tubings. The applicant intends to market the device through franchised and trained dealer installers.

The original application for exemption includes installation instructions for four distinct configurations; they were later simplified to include only two. One configuration involves tapping the secondary air system of the engine and blowing the vapor into the carburetor through a hole in the air filter housing. This configuration was later modified to include installations using an optional electric air pump where it is not practical to tap the secondary air system. The remaining configuration

involves combined intake manifold and carburetor venturi port bleeds. The water vapor is introduced into the engine through the distributor vacuum line which controls the spark advance. Figures A through C depict the installations.

III. MANUFACTURERS CLAIMS

The following claims were made by the applicant.

1. Adds octane
2. Stops octane related preignition/detonation
3. Increases power
4. Reduces carbon
5. Increases plug life
6. Increases engine life
7. Reduces emissions

The staff assumes that item 1 really means "reduces octane requirement". The applicant has agreed to delete claims of "reduces emissions".

IV. TEST RESULTS

The applicant has submitted data indicating that the installation of the device which draws air from the AIR system does not adversely affect the air pump discharge pressure. Total spark advance data obtained from a 1974 Ford Courier was also submitted. The data indicated that the installation of the Bubblizer caused the total spark timing to be retarded by up to 4 degrees. Since the timing of ignition affects the combustion process in the engine cylinder which in turn affects emissions, it was determined that the device would be subjected to cold start emissions tests on the combined manifold and venturi port bleed configuration.

Subsequently the applicant submitted emissions test data generated by the Automobile Club of Southern California. These were CVS-75 tests conducted upon a 1978 Datsun pickup truck belonging to the Auto Club. The vehicle was subjected to two baseline tests (one before and one after tune-up) prior to installation of the Bubblizer.

The total spark advance was checked before and after the installation of the Bubblizer. With the device installed the spark was retarded by up to 4°, confirming the condition found in the 1974 Courier. The maximum retardation was recorded at 3000 RPM. The test data on the Datsun are summarized belows:

CVS-75 Emissions 1978 Datsun Pickup 40,337 Miles				
Test Condition	HC g/mi	CO g/mi	NOx g/mi	Fuel Economy MPG
Baseline 1 (before tune-up)	1.76	8.89	1.42	20.6
Baseline 2 (after tune-up)	1.24	7.38	1.89	21.0
w/Bubblizer	1.25	7.54	.93	19.7
Change from Baseline	+0.8%	+2.2%	-53.0%	-6.2%

The percent changes in hydrocarbon and carbon monoxide emission are considered to be within the limits of laboratory test variability.

V. CONCLUSIONS AND RECOMMENDATION

The staff finds that the Bubblizer does not have an adverse effect upon the emission control system and recommends that Executive Order No. D-108 be adopted.

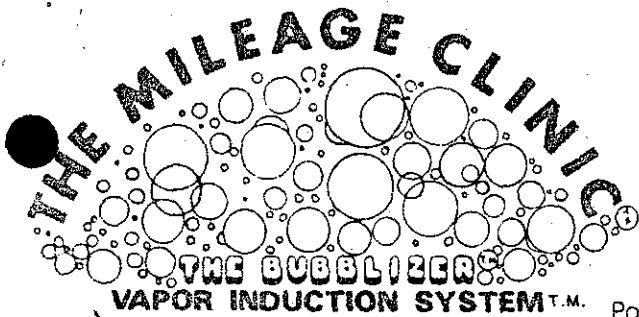

Figure A

Vapor injection upstream of the carburetor using AIR system

Post Office Box 672 • Clearlake Highlands, CA 95422 • (707) 994-8810

INSTALLATION INSTRUCTIONS

PREFERRED ALTERNATIVE INSTALLATION FOR VEHICLES EQUIPPED WITH "SMOG" AIR PUMP

© 1980 The Mileage Clinic. All rights reserved.

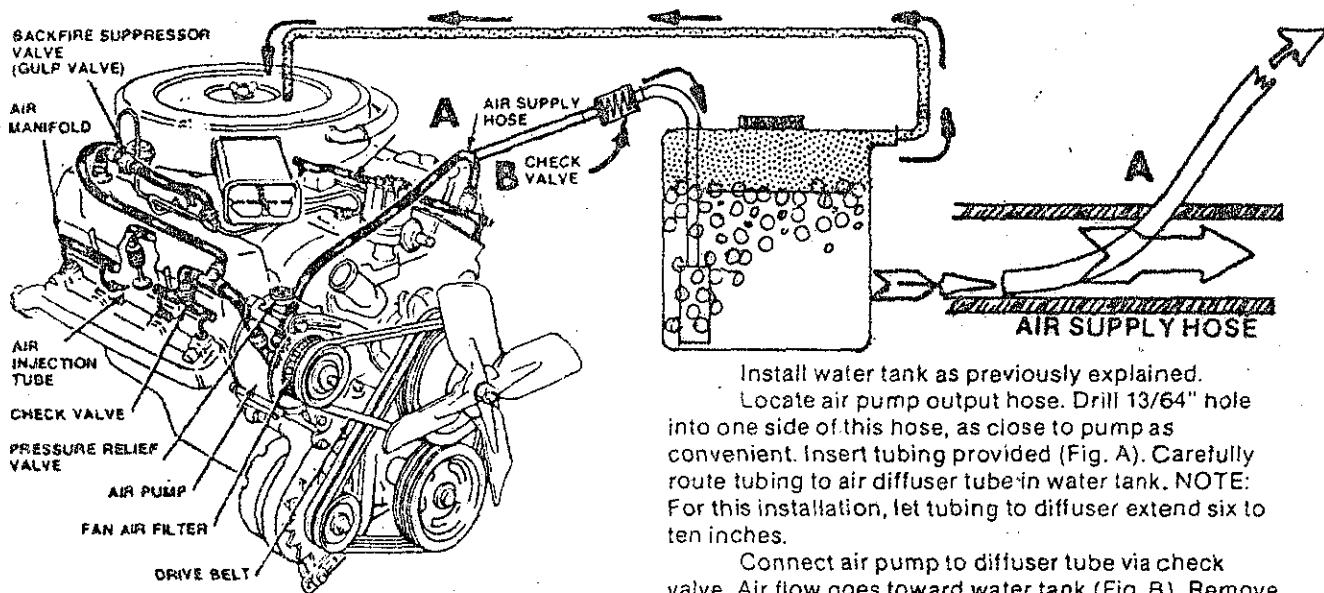

An early-model air injection system.

Install water tank as previously explained. Locate air pump output hose. Drill 13/64" hole into one side of this hose, as close to pump as convenient. Insert tubing provided (Fig. A). Carefully route tubing to air diffuser tube in water tank. NOTE: For this installation, let tubing to diffuser extend six to ten inches.

Connect air pump to diffuser tube via check valve. Air flow goes toward water tank (Fig. B). Remove air cleaner top and drill 15/16" hole in it as close to center as convenient (Fig. C). Insert tubing. Be careful tubing does not interfere with choke operation. Carefully, route this tubing to water tank output.

Save valve in case you sell vehicle and want to have unit installed on vehicle without air pump.

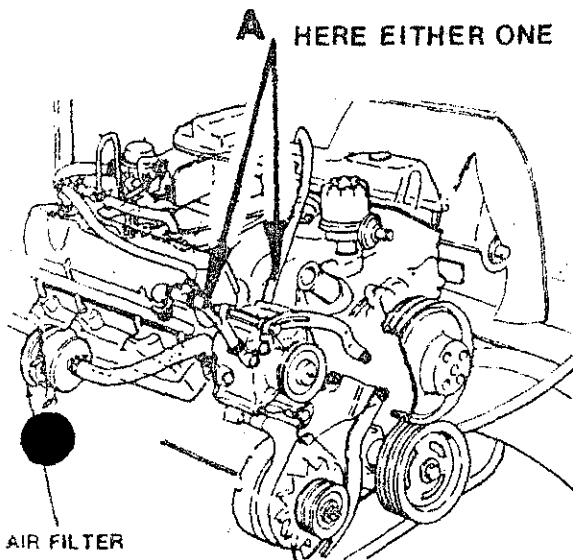

An external filter is used with air pumps in some older cars.

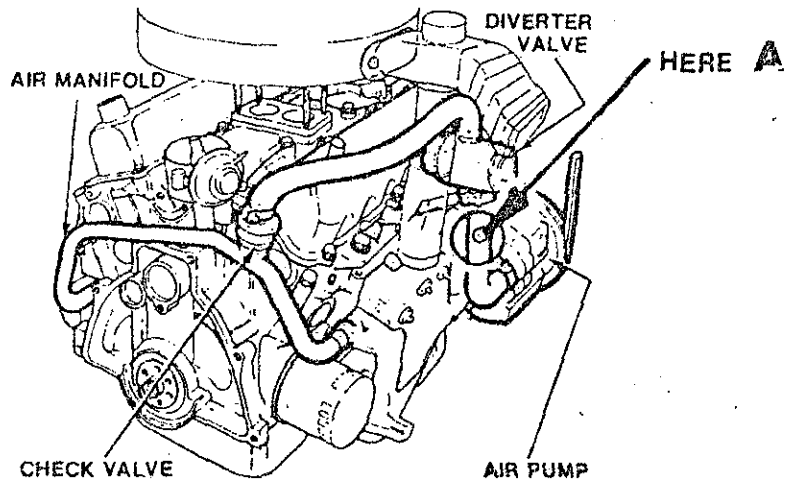

A late-model air injection system. It has fewer parts than the earlier systems. (Ford)

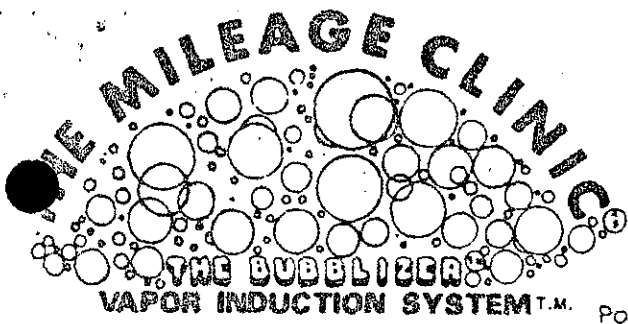

Figure B

Vapor injection through
PCV line or ported vacuum

Post Office Box 672 • Clearlake Highlands, CA 95422 • (707) 994-8810

INSTALLATION INSTRUCTIONS

COPYRIGHT 1980

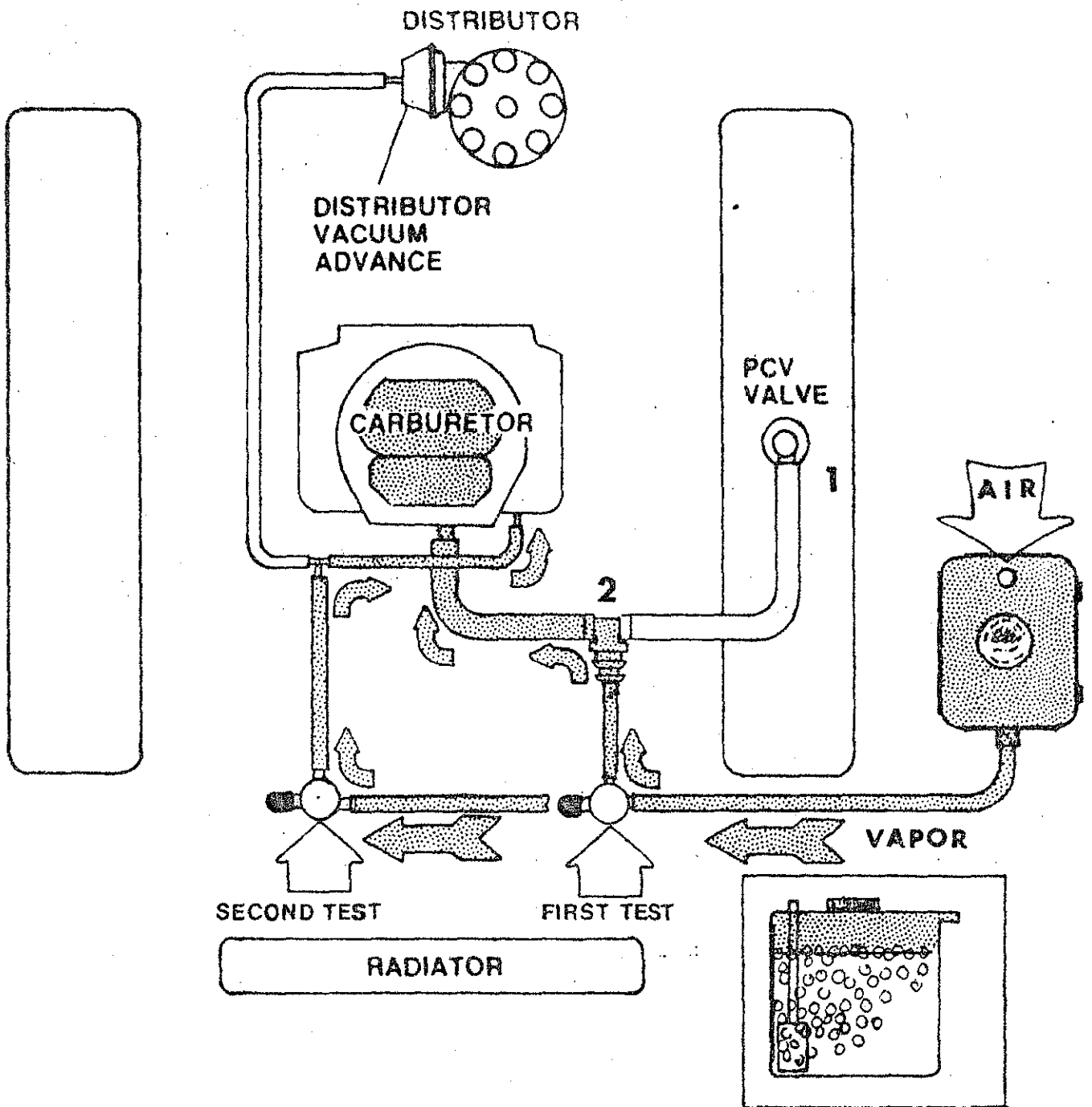

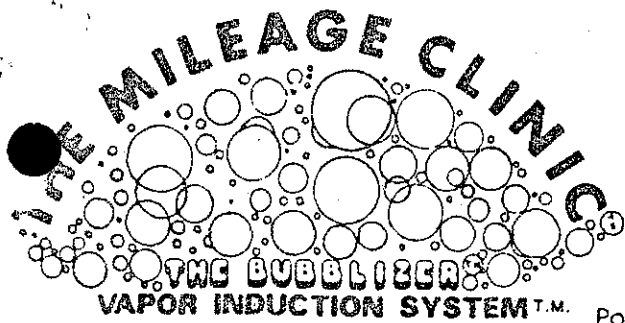

Figure C

Vapor injection through
PVC line and ported vacuum

Post Office Box 672 • Clearlake Highlands, CA 95422 • (707) 994-8810

INSTALLATION INSTRUCTIONS

COPYRIGHT 1980

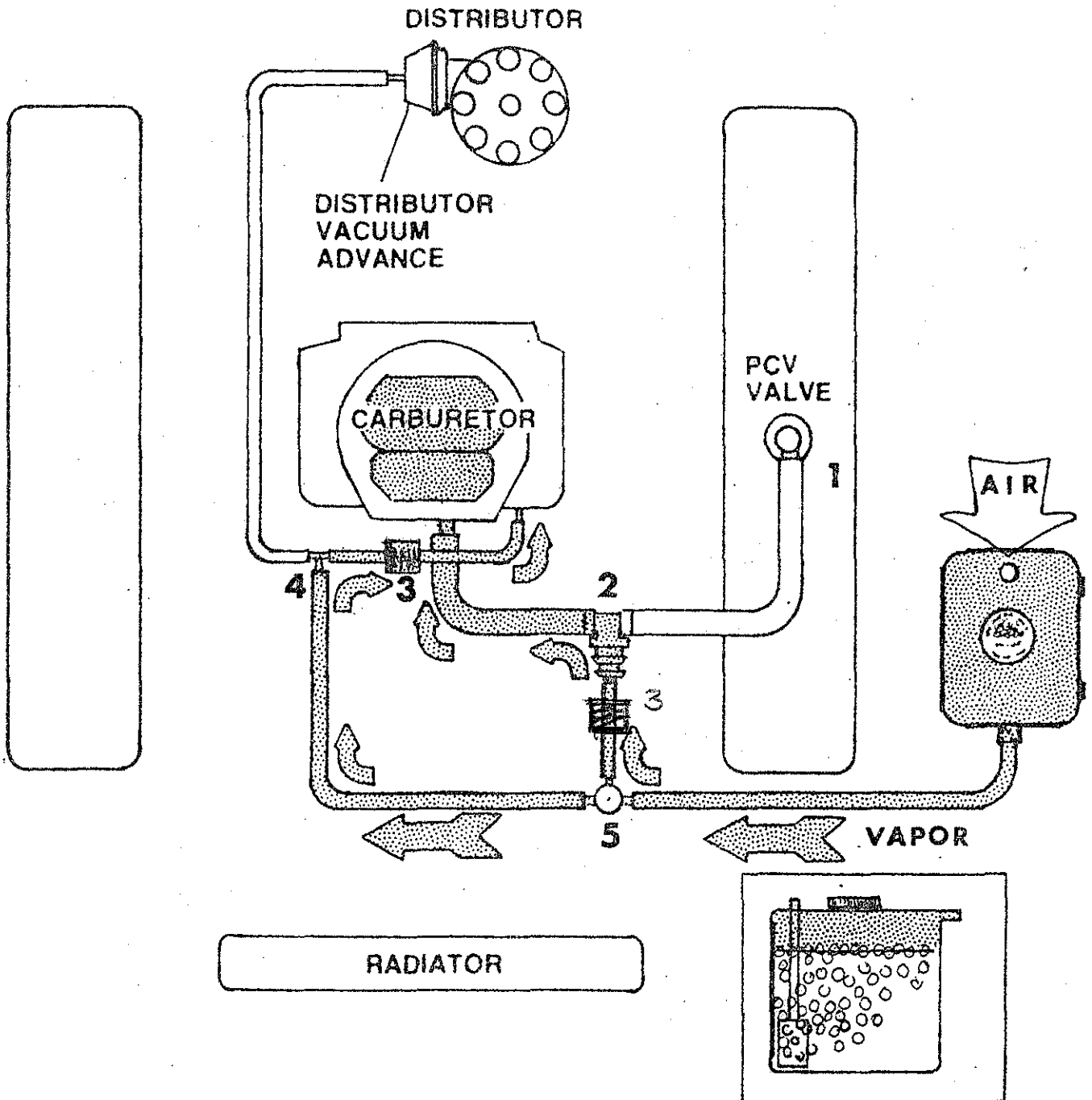

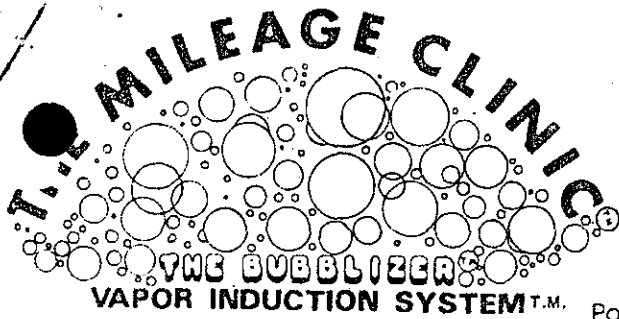

Post Office Box 672 • Clearlake Highlands, CA 95422 • (707) 994-8810

BUBBLIZER INSTALLATION INSTRUCTIONS

(Read completely before starting)

Before installation, be sure your vehicle is in good running order and you know your present miles per gallon.

The Bubblizer can be installed in any convenient place in the engine compartment. It should not be installed too near the exhaust manifold or where anything would rub against the water tank or tubing. It can be mounted facing either side or facing the front of the vehicle.

After deciding on the best location, mark the appropriate place for the mounting screws. The hanger rack may be bent as required. Punch a hole where your marks are, careful not to make too large a hole. Mount the water tank with the sheet metal screws and washers provided.

Locate the P.C.V. hose and valve (manifold vacuum, (Fig. 1)). (Make sure P.C.V. hose and valve are not clogged.) Cut hose as close to carburetor as convenient and insert universal tee, provided, as shown (Fig. 2). Trim off end of tee not used. You may need to replace hose or use hose clamps, if connection is not air tight.

The Bubblizer comes with a smaller 3-way tee for use in a convenient venturi or ported vacuum line. Usually, ported vacuum is the vacuum advance line, however, check to be sure.

Install the check valve in this hose with air flow toward the carburetor (Fig. 3). Now, install the smaller 3-way tee a few inches behind the check valve (Fig. 4). Run a length of the tubing provided from this tee to the P.C.V. tee. Cut this tube in a convenient place and install the control valve exactly as shown (Fig. 5).

Place Bubblizer tube into the top of the water tank. Then, pull the end of the tube out of the top of the tank and install the air diffuser in the tube. Put the tube and air diffuser back into the bottom of the water tank. Carefully, route the left over tubing from the water tank to the control valve (Fig. 5). Fill the tank with water to the full mark. Close cap tightly.

Close valve and start engine. Open valve very slowly and watch for the first sign of bubbles in the tank. This is where you leave the valve for your first test. In all cases, with all engines, start testing with the lowest amount of bubbles. If the valve is opened too much, you will see the sides of the water tank pull in and the water will churn violently. This churning will not produce as much vapor, and indicates the possibility of an overly lean mixture. This could cause a reduction in miles per gallon, which is the last thing you want. Adjust the valve to get the most bubbles, without churning. If there is not an increase in mileage, try opening the valve a little more. If no bubbles appear, be sure cap is tight and there are no vacuum leaks.

There are three important differences in the Bubblizer and other vapor systems. Although, the water tank is made in the same mold as a radiator overflow tank, it is a different material and much heavier. Secondly, the air diffuser is made of tiny glass beads, fused together. It is specially designed to produce more bubbles. The more bubbles bursting, the more vapor. Third, the unusual method of installation is designed to provide vapor under almost all driving conditions.

The P.C.V. hose is manifold vacuum, providing lots of vapor under low to medium load conditions. The ported or venturi vacuum line provides extra vapor under higher load conditions. To gain vapor under the higher load conditions, you generally tap into an existing ported or venturi line. ~~You must consider how the vacuum loss will effect whatever this hose was designed to rate (i.e., the ignition advance curve must meet the specifications of the NOx control retrofit device or manufacturers specifications, if no NOx control exists). If the addition of the Bubblizer changes the advance curve, this connection must either be eliminated or the distributor must be mechanically modified so the aforementioned specifications are met.~~

Another consideration is, certain of these hoses go to devices like the charcoal cannister, which creates an air leak. Any air leak will keep the Bubblizer from working. If there is no noticeable power difference or mileage improvement and the system uses no water, there is undoubtedly an air leak somewhere. In very rare cases, a new port must be drilled in the carburetor or installation may be limited to the P.C.V. hose (or other centrally located manifold vacuum port) ONLY.

The Mileage Clinic does not recommend installation by anyone other than a factory trained technician. If you should install a unit yourself, there is no guarantee of any improvement. If you bought a used Bubblizer, any Mileage Clinic Installation Center will install it for a reasonable fee.

The Bubblizer will help most cars by simply turning it on, however, if you desire maximum results, here are some recommendations.

1. Check all spark plugs for cleanliness and proper gap setting. Gap setting can be advanced 5 to 10 percent wider than manufacturer's recommendations when using the Bubblizer.
2. After installing the Bubblizer, check timing. Timing can, in most cases, be advanced without ping. (CAUTION: Check your state laws before advancing timing.)
3. Reset carburetor. Bubblizer cars can usually run 10% leaner without loss of power or ping.

Refill the Bubblizer every time you get gas. Add a small amount of alcohol to the water in winter to prevent freezing. Amount depends on temperature. If water gets slushy, add more alcohol. Denatured alcohol is available in most hardware and paint stores.

~~DELETIONS PER ATTACHED LETTER~~

ADDENDUM TO AIR PUMP INSTALLATION INSTRUCTIONS

If your vehicle is not equiped with a factory air pump, then, use the optional 12-volt air pump in its place. No check valve is necessary.

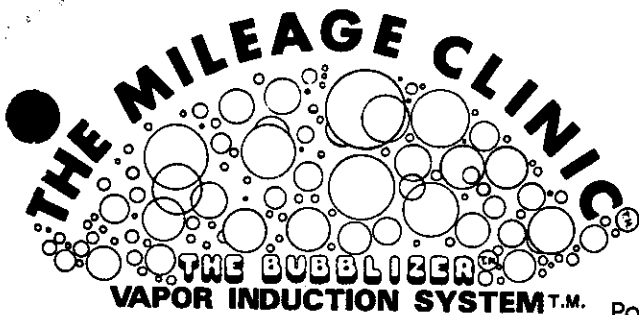

Post Office Box 672 • Clearlake Highlands, CA 95422 • (707) 994-8810

January 3, 1981

Air Resources Board
9528 Telstar Avenue
El Monte, CA. 91731

Attention: Mr. John Chao - Manager
Aftermarket Parts & Modification Evaluation Section

Dear Mr. Chao,

Pursuant to your letter for "Documentation Purposes", I believe you have already received the additional information you have requested.

To reaffirm our phone conversation of 12-30-80, we are only interested in two installation procedures.

Per your letter of 12-23-80, Section 1, A. An above carburetor pressure activated system powered by the AIR system; and, D. A combination of B + C above, there are changes in the installation instructions to cover ignition advance and the Bubblizer valve adjustment.

Since it is illegal to modify a vehicles ignition advance curve to achieve maximum efficiency, we prefer to omit the references to increasing advance. Any specific advance (i.e., 3°), across the board, would not be in the consumers best interest and therefore would be dishonest, in our opinion.

I have enclosed the universal tee you mentioned. If there is anything we have left out or overlooked, please call immediately. Thank you for your cooperation.

Sincerely,

Jason Allen Rothchild

1 enclosure

State of California
AIR RESOURCES BOARD

EXECUTIVE ORDER D-109
Relating to Exemptions under Section 27156
of the Vehicle Code

FREEDOM PRODUCTS, INC.
"AUTO JET HEATER"

Pursuant to the authority vested in the Air Resources Board by Section 27156 of the Vehicle Code; and

Pursuant to the authority vested in the undersigned by Sections 39515 and 39516 of the Health and Safety Code and Executive Order G-45-5;

IT IS ORDERED AND RESOLVED: That the installation of the "Auto Jet Heater" device manufactured by Freedom Products, Inc., P. O. Box 700, Freedom, California 95019 has been found not to reduce the effectiveness of required motor vehicle pollution control devices and, therefore, is exempt from the prohibitions of Section 27156 of the Vehicle Code for use on any 1978 and older model year gasoline powered motor vehicle equipped with 2 or 4 barrel carburetor, excluding the following:

1. Motor vehicles equipped with 3-way catalyst and/or;
2. Motor vehicles equipped with carburetors having sealed idle adjustment screw(s).

This Executive Order is valid provided that installation instructions for this device will not recommend tuning the vehicle to specifications different from those submitted by the device manufacturer.

Changes made to the design or operating conditions of the device, as exempted by the Air Resources Board, that adversely affect the performance of a vehicle's pollution control system shall invalidate this Executive Order.

Marketing of this device using an identification other than that shown in this Executive Order or marketing of this device for an application other than those listed in this Executive Order shall be prohibited unless prior approval is obtained from the Air Resources Board. Exemption of a kit shall not be construed as an exemption to sell, offer for sale or advertise any component of a kit as an individual device.

This Executive Order does not constitute any opinion as to the effect that the use of this device may have on any warranty either expressed or implied by the vehicle manufacturer.

THIS EXECUTIVE ORDER DOES NOT CONSTITUTE A CERTIFICATION, ACCREDITATION, APPROVAL, OR ANY OTHER TYPE OF ENDORSEMENT BY THE AIR RESOURCES BOARD OF ANY CLAIMS OF THE APPLICANT CONCERNING ANTI-POLLUTION BENEFITS OR ANY ALLEGED BENEFITS OF THE "AUTO JET HEATER" DEVICE.

No claim of any kind, such as "Approved by Air Resources Board" may be made with respect to the action taken herein in any advertising or other oral or written communication.

Section 17500 of the Business and Professions Code makes untrue or misleading advertising unlawful, and Section 17534 makes violation punishable as a misdemeanor.

Section 43644 of the Health and Safety Code provides as follows:

"43644. (a) No person shall install, sell, offer for sale, or advertise, or, except in an application to the state board for certification of a device, represent, any device as a motor vehicle pollution control device for use on any used motor vehicle unless that device has been certified by the state board. No person shall sell, offer for sale, advertise, or represent any motor vehicle pollution control device as a certified device which, in fact, is not a certified device. Any violation of this subdivision is a misdemeanor."

Any apparent violation of the conditions of this Executive Order will be submitted to the Attorney General of California for such action as he deems advisable.

Executed at El Monte, California, this 23rd day of February, 1981.

Bob Cross for

K. D. Drachand, Chief
Mobile Source Control Division

State of California
AIR RESOURCES BOARD

Staff Report

February 1, 1981

Evaluation of the Freedom Products, Inc. "Auto Jet Heater"
Device for Compliance with the Requirements of Section 27156
of the Vehicle Code.

I. INTRODUCTION

Freedom Products, Inc., of P. O. Box 700, Freedom, California 95019 has applied for exemption for an aftermarket device from the prohibitions of Section 27156 of the Vehicle Code. The device, known as the "Auto Jet Heater", is intended for use on any 1978 and older model year gasoline powered motor vehicle equipped with 2 or 4 barrel carburetor, excluding for the following:

1. Motor vehicles equipped with 3-way catalyst and/or;
2. Motor vehicles equipped with carburetors having sealed idle adjustment screw(s).

Section 27156 of the Vehicle Code prohibits the installation, sale or advertisement of any device which alters the performance of the vehicle's emission control system. The Air Resources Board is empowered to exempt any device from this prohibition if it can be shown that the installation of the device will not reduce the effectiveness of the existing emission control system.

II. SYSTEM DESCRIPTION AND OPERATION

The "Auto Jet Heater" consists of an elongated idle mixture needle, a heating element inside an insulated metal housing which forms the body of the device, and a wiring harness. The longitudinal sectional view of the device is shown in Figure 1.

For 2 barrel carburetors, two needles and two heating elements are used in conjunction with a single wiring harness. For 4 barrel carburetors, four needles and four heating elements are used in conjunction with a single wiring harness.

The elongated idle mixture needle has a threaded body (metric threads for imported carburetors and standard threads for domestically manufactured carburetors) which securely fits the carburetor and replaces the existing idle adjustment screw. The needle has a tapered tip. When installed, this tip is located inside the discharge port of the idle circuit. The other end of the needle is a projecting stud which is beveled for easy connection with the electrical heating element.

The heating element is enclosed inside a cylindrical metal housing. The needle is secured to and becomes an integral part of the housing. At the other end of the housing, there is a conventional snap-on terminal for connection to the wiring harness which is linked to a 12 volt power source through the ignition system in the vehicle's fuse box (see Attachment A "Installation Instructions" for device installation). When the ignition switch is "ON", the heating element is energized thus heating the needle of the "Auto Jet Heater". When the ignition switch is "OFF", the heating element is not energized and the heater is not functioning.

The purported objective of the device is to heat the fuel that passes through the idle discharge port. This heated fuel when accelerated into the main stream of the air/fuel mixture passing through the carburetor causes the main stream of fuel to be vaporized but without overheating.

III. APPLICANT'S TECHNICAL DATA

The company presented the following technical data of the "Auto Jet Heater" device: Each heating element will consume 2.5 amps of electricity from the vehicle's 12 volt battery during operation. The heat conducted to the tip of the needle of the device will cause the tip to reach a maximum temperature of approximately 130°F.

IV. DEVICE EVALUATION

The applicant submitted test data on a 1963 Volkswagen. The test was performed in February 1964. Since the data is too old, it is not used for ARB's evaluation.

The ARB laboratory bench-tested the device. The device was installed on a conventional 2 barrel carburetor. The elongated idle mixture needles and heating elements were connected to the wiring harness and linked to a 12 volt D.C. power supply as shown in Figure II. Temperature at the tip of one needle is recorded at 10-second intervals. The ARB's test results are as follows:

1. Initial temperature, also ambient temperature, was 70°F.
2. After 2 minutes of energizing the device, the tip temperature reached 100°F.
3. Thereafter, the tip temperature rose at a constant rate of 5°F/minute until a maximum temperature of 120°F was reached.
4. Maximum temperature was attained after 6 minutes from start-up of the device.
5. The second needle's maximum tip temperature was 130°F in 6 minutes.

A graphical interpretation is shown in Figure III.

The ARB also made an engineering evaluation of the device. The staff noted that:

1. Since after installation the needles are adjusted to vehicle manufacturer's recommended idle tune-up parameters, the device will not affect the vehicle's emissions during idle;
2. During off idle operation modes (as in cruising, acceleration, and deceleration), the idle circuit will not contribute significantly to exhaust emissions;
3. The small portion of heated fuel that passes through the idling port does not significantly raise the temperature of the main body or volume of the air fuel mixture that passes through the carburetor throat;
4. The physical design of the tapered tip of the elongated idle mixture needle is similar to that of the original idle adjustment screw in the vehicle's carburetor.

V. CONCLUSION AND RECOMMENDATION

Based on the above, the staff concluded that the installation of the "Auto Jet Heater" will not have adverse effect on vehicle exhaust emissions. The staff recommends that Freedom Products, Inc. be granted an exemption from the prohibitions of the Vehicle Code Section 27156 for its "Auto Jet Heater" device for use on any 1978 and older model year gasoline powered motor vehicle equipped with 2 or 4 barrel carburetor, excluding 3-way catalyst and/or sealed idle adjustment screw equipped vehicles. The staff, therefore, recommends that Executive Order D-109 be adopted.

Figure I: Longitudinal Sectional View of "Auto Jet Heater"

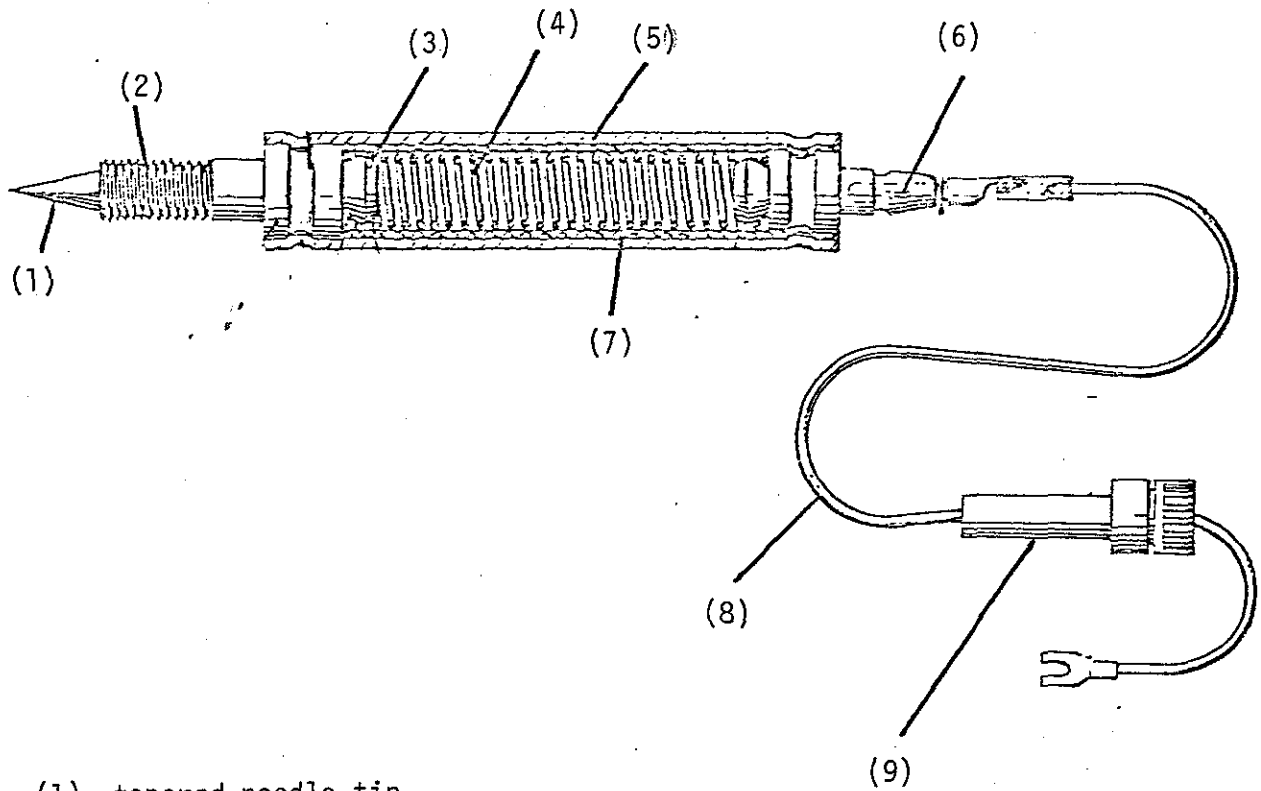

- (1) tapered needle tip
- (2) idle mixture needle
- (3) projecting stud
- (4) heating element
- (5) metallic housing
- (6) snap-on electrical connector
- (7) insulating material
- (8) wiring harness
- (9) 9 amp fuse and fuse holder

Figure II: Bench Test Set-up
(Auto Jet Heater)

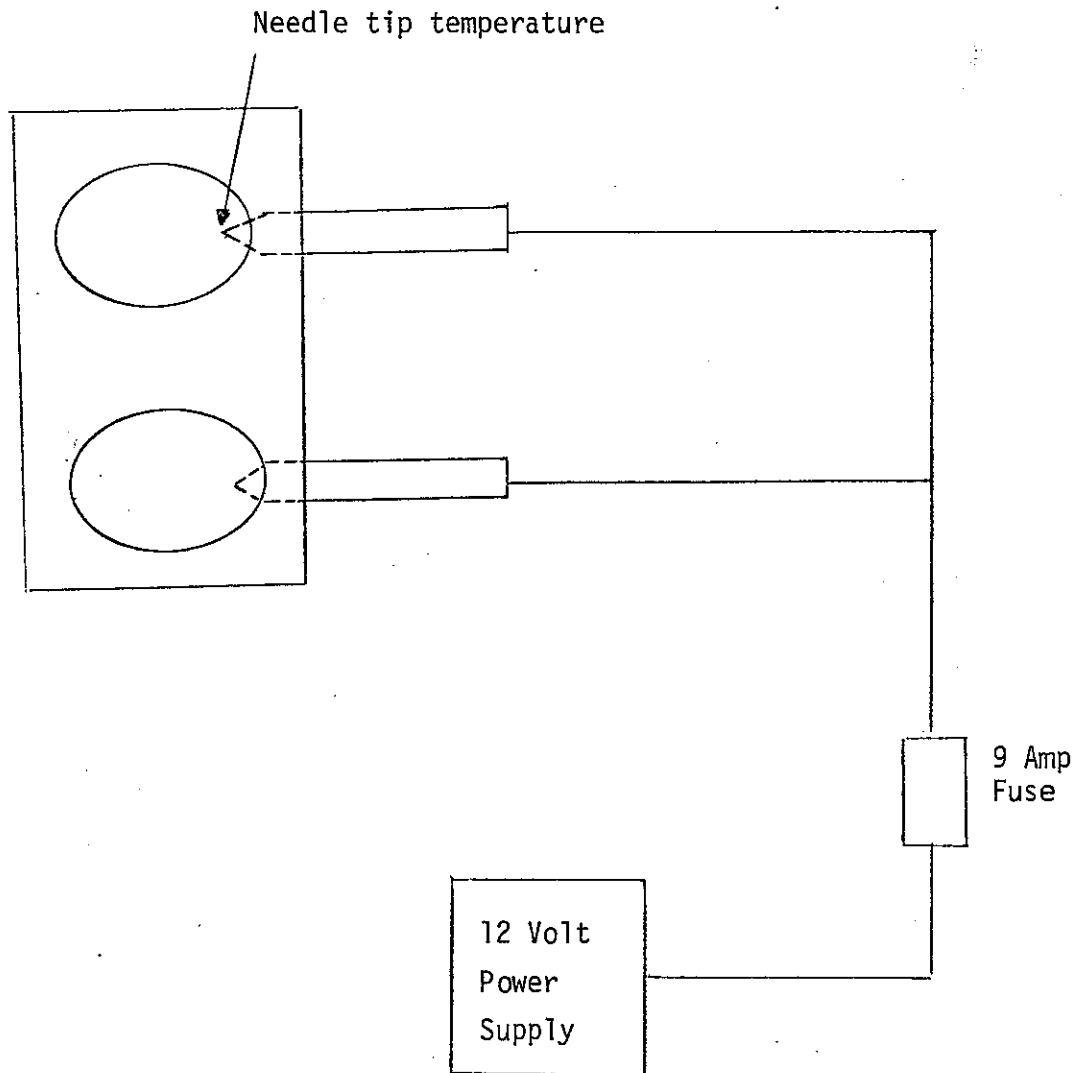
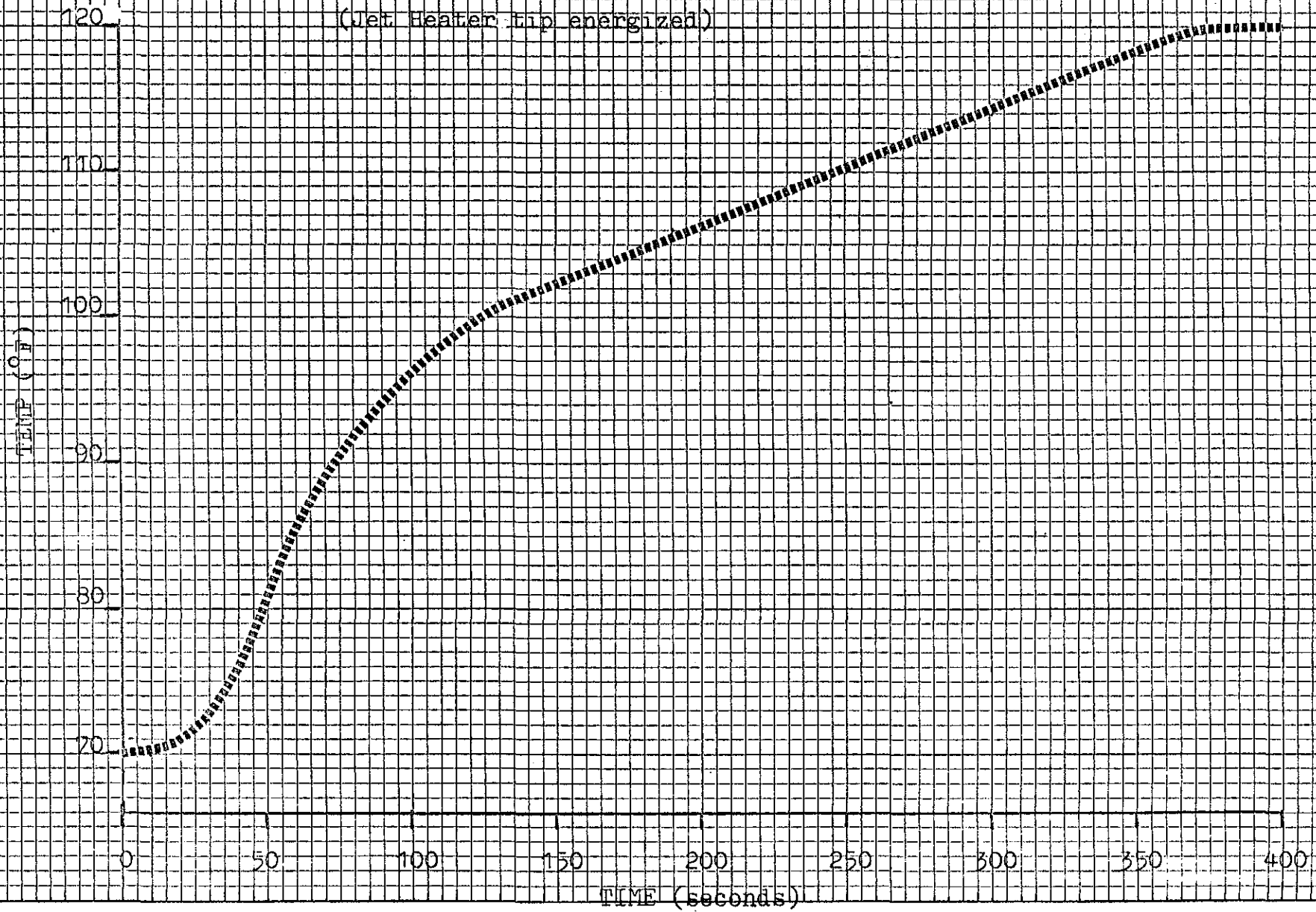

FIGURE III
TIME vs. TEMPERATURE
(Jet Heater tip energized)



ATTACHMENT A:

JET HEATER INSTALLATION INSTRUCTIONS:

The Auto Jet Heater, with the brass needle attached, replaces the existing carburetor idle adjustment screw. The needle is scientifically perfect for most all american carburetors. Should the needle fail to mate with your carburetor, return it to Freedom Products, Inc., P. O. Box 700, Freedom, CA., 95019, stating your carburetor type for a free replacement.

Step 1: Before taking out your carburetor's idle adjustment screw, turn it all the way into its closed position, very carefully counting the turns and parts of turns to do so. It can then be taken out.

Step 2. Next, screw the brass needle into the female end of the heater to approximately the length of the idle adjustment screw you just took from your carburetor. Now tighten jamb nut firmly to heater barrel. **IMPORTANT: GRIP BARREL ONLY ON CRIMPED ENDS.**

Step 3: Heater unit can now be installed in carburetor, after first placing the coil tension spring you took from the idle screw onto the brass needle. If you find the needle is too long, either stretch the tension spring or trim the needle at thread end. Turn heater to full closed position, before backing off the same number of turns and parts of turns counted before you took out the idle screw.

ATTACHMENT A: (cont.)

Page 2

JET HEATER INSTALLATION INSTRUCTIONS:

Step 4: Heater is now ready to set. With engine warmed up and at idle with choke off, adjust needle in until engine nearly dies, then back off slowly until engine barely smooths, then stop. IMPORTANT: DO NOT RESET NEEDLE AFTER ENERGIZING.

Note: With two barrel carburetors, which require two Jet Heaters, it is best to install and set each heater in turn before proceeding to next step.

Step ⁶ 5: Hook up must be made through ignition circuit in your car's fuse box, so that heater operates only when key is on and all the time the engine is running. Most cars have a spare spade fitting in the fuse box, which is located under the dash. If one is not available attach a brass spade to the wire and fit under the metal end of a fuse. IMPORTANT: BEFORE HARNESS HOOK UP REMOVE FUSE FROM HARNESS LINE, REMEMBERING TO REPLACE IT AFTER HOOK UP HAS BEEN MADE.

IMPORTANT: ALL VACUUM LEAKS MUST BE ELIMINATED FROM THE VEHICLE TO INSURE PROPER OPERATION.

STEP 6

INSERT SUPPLIED WIRE IN HOLES IN FORWARD END OF BOTH BARRELS DRAW WIRE TIGHT AND CLAMP SO BARREL IS SECURE ATTACH SEAL FIRMLY OVER WIRE AND CLAMP ATTACH DECAL TO AREA NEAR CARBURATOR