

State of California
AIR RESOURCES BOARD

EXECUTIVE ORDER D-745
Relating to Exemptions under Section 27156
of the Vehicle Code

SWEDEPARTS, INC.
WEBER 32/36 DGV CARBURETOR KIT

Pursuant to the authority vested in the Air Resources Board by Section 27156 of the Vehicle Code; and

Pursuant to the authority vested in the undersigned by Sections 39515 and 39516 of the Health and Safety Code and Executive Order G-45-5;

IT IS ORDERED AND RESOLVED: That the installation of the Weber 32/36 DGV carburetor, distributed by Swedeparts, Inc., San Diego, CA 92110, has been found not to reduce the effectiveness of required motor vehicle pollution control devices and, therefore, is exempt from the prohibitions of Section 27156 of the Vehicle Code for limited 1962-1972 Volvo vehicles with 1.8L or 2.0L displacement engines equipped with either S. U. or Stromberg type original equipment carburetors.

This Executive Order is valid provided that installation instructions for this device will not recommend tuning the vehicle to specifications different from those submitted by the device manufacturer.

Changes made to the design or operating conditions of the device, as exempted by the Air Resources Board, that adversely affect the performance of a vehicle's pollution control system shall invalidate this Executive Order.

Marketing of this device using an identification other than that shown in this Executive Order or marketing of this device for an application other than those listed in this Executive Order shall be prohibited unless prior approval is obtained from the Air Resources Board. Exemption of a kit shall not be construed as an exemption to sell, offer for sale, or advertise any component of a kit as an individual device.

This Executive Order does not constitute any opinion as to the effect that the use of this device may have on any warranty either expressed or implied by the vehicle manufacturer.

THIS EXECUTIVE ORDER DOES NOT CONSTITUTE A CERTIFICATION, ACCREDITATION, APPROVAL, OR ANY OTHER TYPE OF ENDORSEMENT BY THE AIR RESOURCES BOARD OF ANY CLAIMS OF THE APPLICANT CONCERNING ANTI-POLLUTION BENEFITS OR ANY ALLEGED BENEFITS OF THE WEBER 32/36 DGV CARBURETOR.

No claim of any kind, such as "Approved by Air Resources Board" may be made with respect to the action taken herein in any advertising or other oral or written communication.

Section 17500 of the Business and Professions Code makes untrue or misleading advertising unlawful, and Section 17534 makes violation punishable as a misdemeanor.

Section 43644 of the Health and Safety Code provides as follows:

"43644. (a) No person shall install, sell, offer for sale, or advertise, or, except in an application to the state board for certification of a device, represent, any device as a motor vehicle pollution control device for use on any used motor vehicle unless that device has been certified by the state board. No person shall sell, offer for sale, advertise, or represent any motor vehicle pollution control device as a certified device which, in fact, is not a certified device. Any violation of this subdivision is a misdemeanor."

Any apparent violation of the conditions of this Executive Order will be submitted to the Attorney General of California for such action as he deems advisable.

Executed at El Monte, California, this 23rd day of January, 1984.

K. D. Drachand, Chief
Mobile Source Division

State of California
AIR RESOURCES BOARD

EVALUATION OF SWEDEPARTS, INC.'S WEBER 32/36 DGV AFTERMARKET REPLACEMENT
CARBURETOR KIT FOR EXEMPTION FROM THE PROHIBITIONS IN VEHICLE CODE SECTION
27156, IN ACCORDANCE WITH SECTION 2222, TITLE 13, OF THE CALIFORNIA
ADMINISTRATIVE CODE

December, 1983

State of California
AIR RESOURCES BOARD

EVALUATION OF SWEDEPARTS, INC.'S WEBER 32/36 DGV AFTERMARKET REPLACEMENT
CARBURETOR KIT FOR EXEMPTION FROM THE PROHIBITIONS IN VEHICLE CODE SECTION
27156, IN ACCORDANCE WITH SECTION 2222, TITLE 13, OF THE CALIFORNIA
ADMINISTRATIVE CODE

by

Mobile Source Division

State of California
Air Resources Board
9528 Telstar Avenue
El Monte, CA 91731

(This report has been reviewed by the staff of the California Air Resources Board and approved for publication. Approval does not signify that the contents necessarily reflect the views and policies of the Air Resources Board, nor does mention of trade names or commercial products constitute endorsement or recommendation for use.)

SUMMARY

Swedeparts, Inc. has requested exemption from the prohibitions in Vehicle Code Section 27156 for an aftermarket replacement carburetor kit for limited 1962-1972 model-year Volvos. The replacement kit is designed to replace the stock dual side-draft carburetors with an aftermarket, single, two-venturi Weber 32/36 DGV carburetor.

The applicant performed comparative exhaust emissions tests which revealed that:

- i) old (1962-1972) Volvos, even well maintained, are high emitters; and
- ii) the aftermarket carburetor kit corrects the over-rich operating condition of the O.E. carburetors on these vehicles.

Based on the above, the staff recommends that Swedeparts, Inc.'s aftermarket replacement carburetor kit be exempted and that Executive Order D-145 be issued.

CONTENTS

	<u>PAGE</u>
SUMMARY	i
CONTENTS	ii
I. <u>INTRODUCTION</u>	1
II. <u>CONCLUSIONS</u>	1
III. <u>RECOMMENDATIONS</u>	2
IV. <u>DEVICE DESCRIPTION</u>	2
V. <u>DEVICE EVALUATION</u>	4
VI. <u>DISCUSSION</u>	6

State of California
AIR RESOURCES BOARD

Evaluation of Swedeparts, Inc.'s Weber 32/36 DGV Aftermarket Replacement Carburetor Kit For Exemption From the Prohibitions in Vehicle Code Section 27156, in Accordance with Section 2222, Title 13, of the California Administrative Code

I. INTRODUCTION

Swedeparts, Inc., ^{3403 Hancock St.} San Diego, California 92110, has requested exemption from the prohibitions in Vehicle Code Section 27156 for an aftermarket replacement carburetor kit. The kit contains a progressive two-venturi Weber model 32/36 DGV carburetor, a Canon intake manifold, an air cleaner housing with element, a PCV valve, carburetor linkage, and installation/adjustment instructions. The kit is intended to replace the original equipment (O.E.) carburetors and intake manifold found on limited 1962-1972 Volvos with 1.8L and 2.0L four-cylinder engines originally equipped with either S.U. or Stromberg carburetors. The purported reason for the aftermarket replacement carburetor kit is that O.E. carburetors and parts are becoming obsolescent and, due to aging and deterioration, have contributed to increased vehicular emissions. The applicant, in order to demonstrate that the Weber kit corrects the over-rich operating condition of the O.E. carburetors, performed comparative emission tests.

This report describes the evaluation of Swedeparts, Inc.'s carburetor kit and discusses the findings.

II. CONCLUSIONS

Based on the results of the applicant's comparative emission tests and on an engineering evaluation of the replacement components found within the kit, the staff has concluded that:

i) older model-year Volvos with OE carburetors are high emitters, even after extensive repairs have been performed;

ii) the aftermarket replacement carburetor kit corrects the over-rich operating condition of the O.E. carburetors;

iii) the aftermarket replacement carburetor kit does not upset the operation of emission controlling components found on the applicable engines; and

iv) the aftermarket replacement carburetor kit contains a superior PCV system to replace the fixed orifice type normally found on these engines.

III. RECOMMENDATIONS

Contingent upon the above conclusions, the staff recommends that Swedeparts, Inc. be granted exemption from the prohibitions in Vehicle Code Section 27156 for the aftermarket Weber 32/36 DGV carburetor kit for limited 1962-1972 Volvos with 1.8L or 2.0L four-cylinder engines originally equipped with S.U. or Stromberg carburetors, and that Executive Order D-145 be issued.

IV. DEVICE DESCRIPTION

The Swedeparts, Inc.'s aftermarket carburetor kit contains the following:

i) a Weber model 32/36 DGV carburetor with modifications;

ii) a Canon model 2844 aluminum intake manifold;

iii) a SAC Model I air cleaner housing and element;

iv) a CV-584C PCV valve;

v) carburetor linkage; and

vi) installation and adjustment instructions.

The Weber model 32/36 DGV is an Italian made carburetor imported by Redline, Inc. in Torrance, California, and packaged by Swedeparts, Inc. It is a down-draft dual venturi progressive type carburetor with a manual choke. It has individual accelerator, float, power, idle, main and manual choke circuits. The Weber carburetor replaces either twin single-venturi S.U. or twin single-venturi Stromberg side-draft type carburetors also equipped with manual chokes.

The Weber model 32/36 DGV receives several modifications made by Swedeparts, Inc. prior to being put into their kit. The modifications include changing of certain jets to tailor the carburetor to the vehicle and the addition of an electronic fuel shut-off solenoid to prevent dieseling when the vehicle is shut off. Table 1 identifies the modifications performed to each carburetor.

Table 1
Carburetor Modification Performed to the Weber 32/36 DGV
by Swedeparts, Inc.

	Main Jet (MM)		Air Corrector Jet (MM)		Idle Jet (MM)		Emulsion Tube		Electric Idle Sol.	
	<u>Prm.</u>	<u>Sec.</u>	<u>Prm.</u>	<u>Sec.</u>	<u>Prm.</u>	<u>Sec.</u>	<u>Prm.</u>	<u>Sec.</u>	<u>Prm.</u>	<u>Sec.</u>
<u>Stock Weber</u>	1.35- 1.45	1.30- 1.40	1.65	1.60	0.50- 0.60	0.50- 0.55	F-5	F-5	No	No
<u>Swedeparts Weber</u>										
<u>Manual Transmission</u>	1.40	1.35	1.65	1.60	0.55	0.50	F-5	F-5	Yes	No
<u>Automatic Transmission</u>	1.40	1.35	1.65	1.60	0.60	0.50	F-5	F-5	Yes	No

Since the Weber 32/36 DGV is of a totally different design from the O.E. carburetors, a new intake manifold with the proper mounting flange is needed. The applicant provides a Canon #2844 aluminum intake manifold with the kit. To prevent fuel in the carburetor bowl from percolating during the soak period, an insulator gasket is installed between the carburetor and intake manifold inlet. The kit also contains a new SAC model 1 air cleaner housing and element.

The crankcase ventilation system is altered with the replacement carburetor kit since the fixed orifice vacuum source on the O.E. manifold is removed and not replaced with the Canon manifold. In place of the fixed orifice a conventional PCV valve (CV-584C) is used.

New throttle linkage is supplied to remotely connect the accelerator pedal to the new carburetor's throttle shafts.

The applicant also provides installation and adjustment instructions to properly install the replacement carburetor kit.

VI. DEVICE EVALUATION

The applicant, in order to demonstrate the merit of the aftermarket carburetor kit, performed comparative emission tests at International Testing Laboratories in Santa Ana, California. A representative test vehicle was used which was purported not to have been modified and to be in good working order. A baseline test (with stock S.U. carburetors) was performed and then the aftermarket carburetor replacement kit was installed and device tested in the same manner. The vehicle tested is described in Table 2 and the comparative emission test results are found in Table 3.

Table 2

Test Vehicle Description

Year	1969
Make	Volvo
Model	145S
Engine Size	1.8L
Carb. Type	S.U.
Emission Controls	E.M., PCV(1)
Mileage	200,000*
Condition	Good

(1) E.M. = Engine Modification; PCV = Positive Crankcase Ventilation
 *Engine was rebuilt 5,000 miles prior.

Table 3

Comparative Exhaust Emissions Results
(CVS-72)

<u>Condition</u>	<u>Exhaust Emissions gm/mi</u>			<u>City Fuel Economy in mi/gal</u>
	<u>HC</u>	<u>CO</u>	<u>NOx</u>	
Baseline	3.2	127.5	2.1	14.9
Device	2.6	59.8	2.9	15.7
1973 Calif. Std.	3.2	39.0	3.0	-

A newer model-year test vehicle was obtained by the applicant for the evaluation but was found to be a gross emitter. This problem is common with vehicles approaching obsolescence. The vehicle as tested had an engine overhaul 5,000 miles prior to testing and no modifications from the stock condition were made.

The test vehicle's O.E. carburetors were first adjusted to specifications before testing was initiated. However, subsequent rechecking revealed erratic operation which resulted in their overhaul. Parts to overhaul the O.E. carburetors were generally not available in the United States and had to be special-ordered from Europe. After overhaul, the O.E. carburetors were adjusted to specifications and found to be operating consistently.

The ARB did not perform confirmatory testing of the conversion kit due to the unavailability of a properly maintained test vehicle.

VI. DISCUSSION

The baseline emissions of the 1969 test vehicle and a newer model-year Volvo show that these used cars are gross emitters of carbon monoxide.

A review of the applicant's test data revealed that during cold operation the stock carburetors ran 50% richer than the aftermarket carburetor even though during cold operation the same choking procedure was used for both carburetors since each was equipped with a manual choke. During hot operation they ran 270% richer than the aftermarket carburetor; this was found consistent during both the low speed and high speed portions of the test. The Weber 32/36 DGV aftermarket replacement carburetor kit successfully corrected the over-rich operating condition of the O.E. carburetors thus drastically cutting down the CO emissions of the test vehicle and, on the whole, reduced the number of high emitters from the vehicle population.

In exchanging the two separate single-venturi O.E. carburetors to a single Weber two-venturi carburetor, a new intake manifold is necessitated. The Canon aftermarket aluminum manifold, used in the kit, contains features not found on the O.E. manifold. Two modes of heat transfer, radiation from the exhaust manifold and conduction from the engine coolant, are used to enhance vaporization of the fuel and to prevent condensation from occurring within its internal passages.

In some cases, depending upon the year-model to be converted, the conversion requires the stock exhaust and intake manifolds to be separated by cutting. The O.E. intake manifold is then discarded and the O.E. exhaust manifold is retained after being sealed by welding the cut area.

The conversion kit contains a new PCV valve to replace the existing fixed orifice crankcase ventilation system. Fixed orifice systems are prone to plugging due to improper care. Modern PCV valves are superior since they continuously clean the internal orifice due to their giggle-pin design.

The replacement air cleaner housing found within the kit does not change the thermostatic operation of the heated air intake (on vehicles so equipped) since the O.E. controller is external from the housing and ducted to the replacement air cleaner housing's single air inlet. A tube fitting is also provided on the replacement housing to allow filtered fresh air to enter the crankcase due to the suction created by the PCV system.

The adjustment instructions of the replacement Weber conversion kit recommend an idle CO setting of 2.0% which is below that of the maximum allowable emission inspection limit.

The distributor vacuum signal retains the same source (manifold vacuum) with the conversion kit.

Since the Weber aftermarket replacement carburetor kit is able to remedy the over-rich operating condition of the O.E. carburetors on some old (1962-1972) Volvos, the staff recommends that the kit be exempted from the prohibitions in Vehicle Code Section 27156 and that Executive Order D-145 be issued.

Volvo vehicles (1968-1970 model-years) with their dual carburetors were exempt from the mandated retrofit add-on NOx device program. Since only a limited number of these vehicles will be affected, the staff recommends that these vehicles continue to retain their exempt status with the Weber conversion kit.

S.U. Carburetors

HIF6 TYPE 1-BARREL

Volvo 140 B20B Engine (1971-72)

NOTE - In 1972 B20B engine was sold in Canada only.

DESCRIPTION

Carburetor is a side draft emission control type. The vacuum chamber has a piston which moves up and down, depending upon manifold vacuum. This piston controls air flow through the carburetor, and therefore controls acceleration. Piston is damped by oil filled chamber; which prevents piston from rising too rapidly on acceleration and yet allows mixture to increase in richness for sudden acceleration. For cold starts, a cold start valve provides an extra amount of air/fuel mixture and a fast idle cam increases engine RPM. Carburetor is also equipped with a temperature controlled fuel jet, overrun poppet valve (in throttle butterfly), and a hot start valve. Temperature controlled fuel jet, thermostatically controls air/fuel ratio over a wide range of operating temperatures. Overrun valve prevents overrich mixtures when throttle is closed suddenly (deceleration). Hot start valve vents hot fuel vapor from float chamber to prevent hard starting when engine is hot.

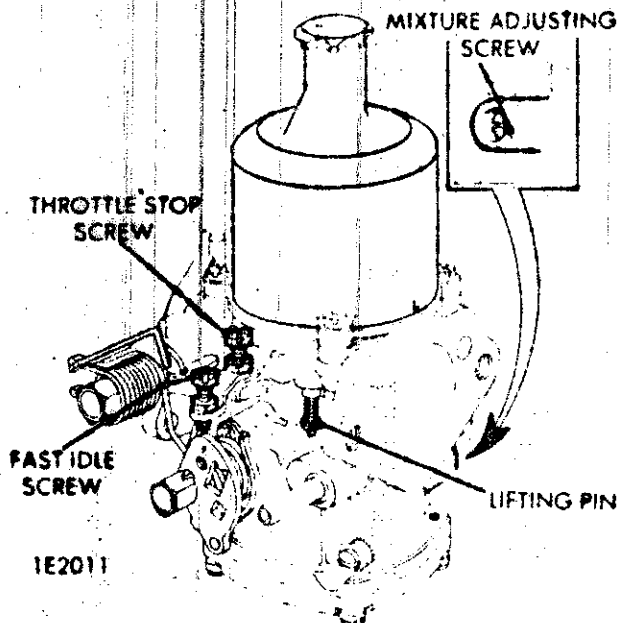

S.U. HIF6 TYPE 1-BARREL CARBURETOR

OPERATION

COLD STARTING

When choke is pulled, a cold start valve and a fast idle cam are actuated on front carburetor. Cold start valve spindle is hollow and has a V-slot linked to a transverse hole. As spindle is rotated, fuel flows from float chamber through spindle to venturi. The V-slot in spindle regulates amount of fuel passing through spindle, until spindle reaches a limit of rotation, at which time transverse hole aligns with passage to venturi allowing maximum flow of system. Also as spindle is rotated, a fast idle cam increases engine RPM.

HOT START VALVE

The purpose of hot start valve is to regulate an outlet from a passage in float chamber. When engine is hot or during high ambient temperatures, fuel vapors form in float chamber. With throttle set at idle, hot start valve is opened to allow fuel vapors to be vented from float chamber. When throttle is opened, hot start valve is closed to external venting and a passage is opened running to air cleaner. Fuel vapors are drawn into air cleaner and mixed with incoming air. By venting float chamber, hard starts are avoided when engine is hot.

NORMAL OPERATIONS

Air entering carburetor intake increases in speed when it crosses a constrictive area called the bridge. Fuel from jet is supplied at this point. Movement of piston is determined by amount of vacuum in intake system. As vacuum increases, piston rises, allowing greater fuel from jet, and air from intake to be admitted to engine.

ACCELERATION

Movement of the piston in vacuum chamber is damped by a plunger in an oil filled cylinder at top of carburetor. This damper prevents piston from rising too rapidly. This delay or dampening allows fuel from jet to be mixed with a smaller amount of air than usual, and enriches mixture. This enriched state is necessary for sudden throttle increase.

IDLING

There is no separate idling system, as this is accomplished through normal running of carburetor. Due to up and down movement of piston in vacuum chamber, air volume is varied continuously. When engine is at idle, only a small amount of air/fuel mixture passes through carburetors. Throttle valves are held in a slightly open position by the idle stop screws. Idling of multiple carburetor systems is adjusted independently. Air/fuel mixture is adjusted by adjusting screws. These are located on front, right-hand side of carburetor. The air/fuel mixture screws are preset at factory to maintain a CO level of 2-3%. Screws are covered by plastic plugs and should not need adjustment.

AUTOMATIC MIXTURE CONTROL

A bi-metal spring located in float chamber controls height of fuel jet. As fuel temperature varies in float chamber, the bi-metal spring bends automatically varying fuel mixture ratio to compensate for different viscosities of fuel.

OVERRUN VALVE (POPPET VALVE)

This small air-operated spring-loaded valve is set in throttle valve (see illustration). At high intake manifold vacuum (such as engine overrun or coasting with throttle closed), vacuum

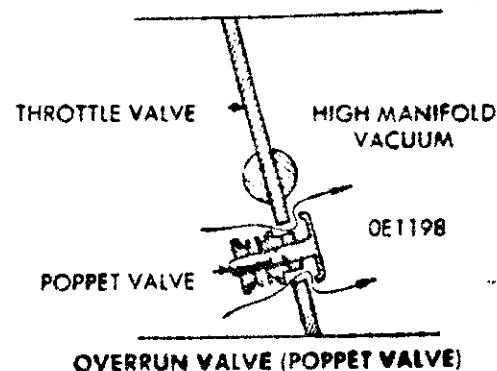

OVERRUN VALVE (POPPET VALVE)

HIF6 TYPE 1-BARREL (Cont.)

overcomes valve spring to open valve. With valve open normal volume of air/fuel mixture is supplemented, and with a retarded ignition timing setting, correct combustion is obtained.

ADJUSTMENTS

IDLE ADJUSTMENT

NOTE - Check visually that both air valves have the same amount of lift after doing basic idle adjustment on Volvo 140. A more accurate synchronization is not required because of balance tube in intake manifold.

NOTE - Since carburetors are equipped with temperature controlled jets, floatchambers should be about the same temperature before starting adjustment. Prolong idling will cause loss of temperature regulation.

- 1) Remove air cleaner.
- 2) Lift air valve and screw in mixture adjusting screw until fuel jet is level with bridge in venturi. Then lower jet by turning mixture adjusting screw 2 1/2 turns clockwise. **NOTE** - This is basic setting for a carburetor at 68°F (20°C). If temperature is above 68°F (20°) turn screw less than 2 1/2 turns and if lower turn more than 2 1/2 turns.

- 3) Connect a tachometer and a CO meter. Run engine until water thermostat opens.

Adjust idle speed to 800 RPM (Man. Trans.), 700 RPM (Auto. Trans.) using throttle stop screws.

- 5) With CO meter, screw mixture adjusting screws in equally, until a CO value of 2-3% is reached. Before each adjustment briefly accelerate engine so that air valves are in their proper position.

- 6) Without CO meter, screw mixture adjusting screws in equally until maximum idling speed is obtained. Then unscrew until engine speed just begins to drop. Replace plastic plugs over mixture adjusting screws.

HOT START VALVE

With control rods pressed down to their bottom position, distance measured between rod and adjusting screw should be a maximum of .04" (1.0 mm) (see illustration).

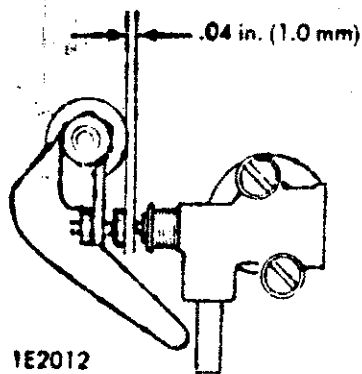

1E2012

HOT START VALVE ADJUSTMENT

FAST IDLE

Pull choke knob out 1" (25 mm) from dash. Adjust fast idle to 1400 RPM (adjust on each carburetor equally).

FLOAT LEVEL

Invert carburetor and remove float chamber screws. Distance between float and flange is 1/64-1/16" (.5-1.5 mm) (see illustration).

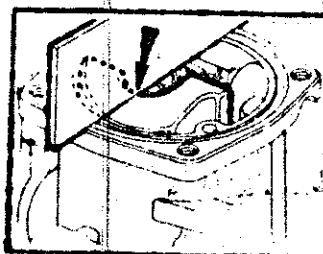

1/64-1/16 in.
(.5-1.5 mm)

1E2013

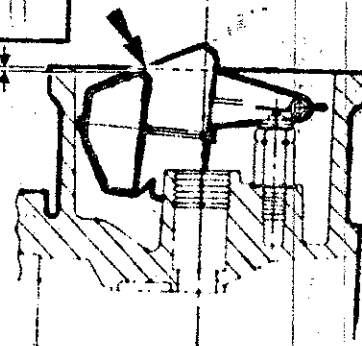

FLOAT LEVEL ADJUSTMENT

METERING NEEDLE

Place needle in air valve with etched mark pointing away from holes in air valve (see illustration). Place guide bushing over needle and set flush with air valve. Take care not to over tighten setscrew.

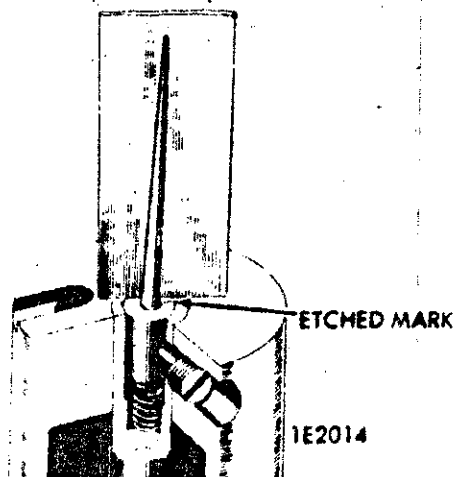

ETCHED MARK

1E2014

METERING NEEDLE ADJUSTMENT

S.U. Carburetors

HIF6 TYPE 1-BARREL (Cont.)

OVERHAUL

DISASSEMBLY

- 1) Remove air cleaner and rod ball joints from carburetors. Remove all hoses and choke cable. Remove nuts and washers from mounting studs and take off carburetors.
- 2) Remove piston damper and its washer.
- 3) Unscrew piston suction chamber retaining screws and remove identification tag.
- 4) Lift chamber vertically from body without tilting it. Remove piston spring and piston assembly.
- 5) Unscrew needle guide locking screw. Withdraw needle guide and spring.
- 6) Mark bottom cover plate and body to ensure correct reassembly. Remove screws and cover plate complete with sealing ring.
- 7) Remove mixture adjusting screw and "O" ring.
- 8) Remove jet adjusting lever retaining screw and spring.

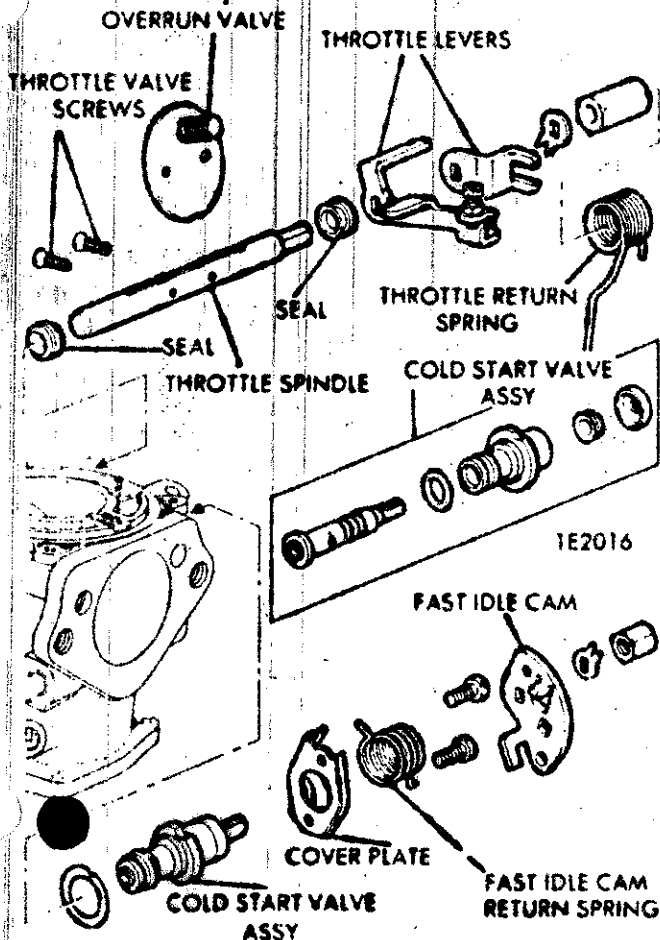

S.U. HIF6 CARBURETOR DISASSEMBLY

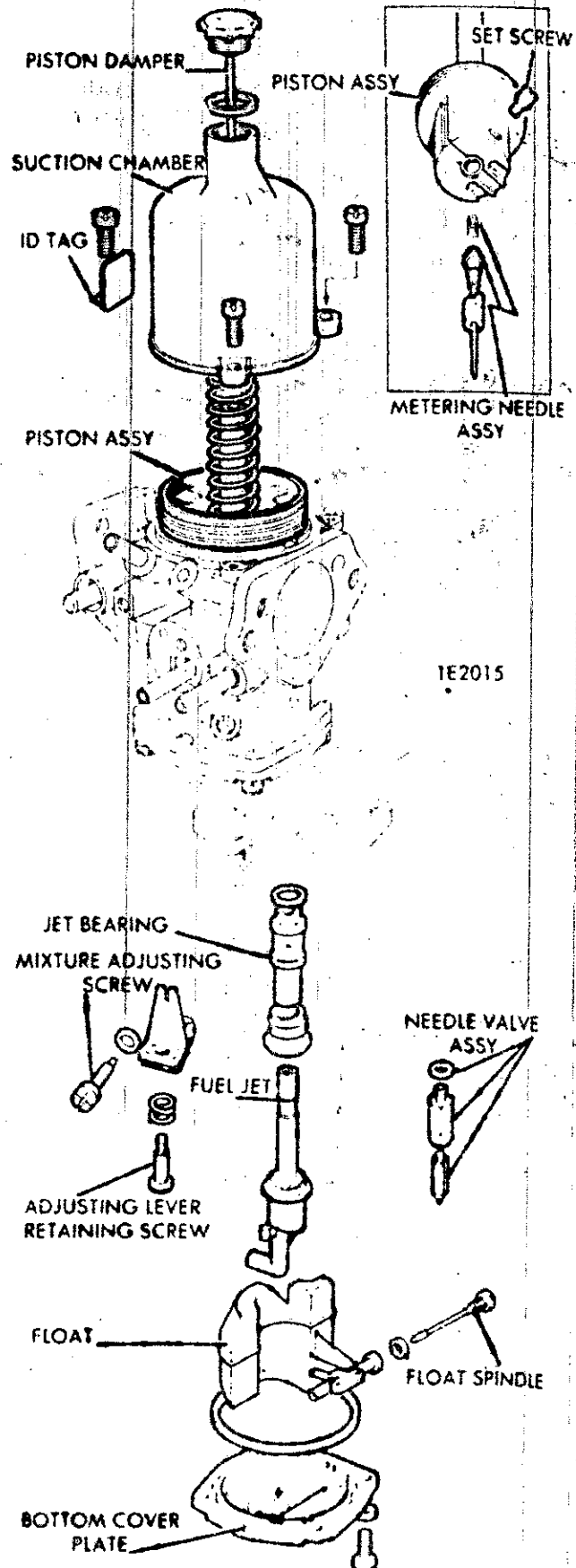

S.U. HIF6 CARBURETOR DISASSEMBLY

HIF6 TYPE 1-BARREL (Cont.)

- 9) Withdraw jet complete with adjusting lever. Disengage lever and disengage bi-metal temperature control spring (Valve 140) using core not to bend spring.
- 10) Remove float spindle and fiber washer. Then remove float and unscrew float needle and valve.
- 11) Unscrew jet bearing lock nut and withdraw bearing complete with fiber washer.
- 12) Remove fast idle cam retaining nut and washer. Note position of cam and lever.
- 13) With return spring held towards carburetor body, pry off cam lever and remove return spring.
- 14) Remove screws from cover of cold start valve and withdraw cold start valve assembly. Pull out valve spindle, "O" ring, seals and dust cap.
- 15) Note location and loading of ends of throttle lever return spring and remove spring. Remove nut and tab washer retaining throttle levers.
- 16) Remove throttle lever and throttle actuating lever.
- 17) Remove throttle valve retaining screws. Withdraw throttle valve taking care not to damage throttle overrun poppet valve. **NOTE** - New throttle valve retaining screws must be used on reassembly.
- 18) Withdraw throttle spindle and seals.

TROUBLE SHOOTING & TESTING

PISTON STICKING

The suction disc, piston, and needle all have suitable clearances to prevent sticking. If sticking does occur, the whole assembly should be carefully cleaned and piston rod should be lubricated with a spot of thin oil. **NOTE** - Do not apply oil to any part except piston rod. To test for a sticking piston, remove piston damper and lift piston with a pencil or similar instrument. The piston should come up freely and fall freely back on bridge when released. Piston return spring should not be stretched or increased in tension to improve the rate of piston return. To check for proper function of air valve, remove suction chamber and air valve. Remove air valve spring and plug holes in bottom of air valve. Return air valve to chamber. Using a nut, screw and flat washer (see illustration), place flat washer so that it goes over edge of suction chamber to prevent air valve from being dropped. Raise air valve up against flat washer and then release. It should take 5-7 seconds for air valve to fall the full extent of its travel. If after thorough cleaning and checking for damage, timing doesn't fall within 5-7 seconds replace air valve and suction chamber.

CARBURETOR FLOODING

If flooding occurs check float needle and float needle seat. Clean thoroughly and inspect for any signs of wear. If wear is found replace needle and needle seat. Recheck float level setting when replacing float needle assembly.

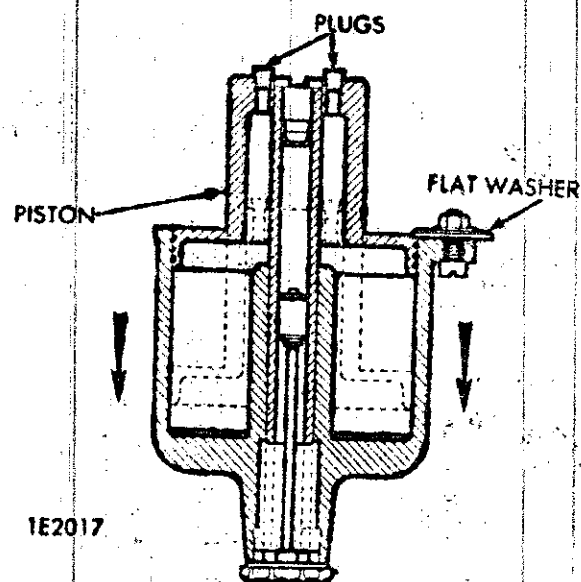

AIR VALVE TIMING CHECK

MAINTENANCE

CARBURETOR LUBRICATION

The reservoir on each carburetor must be filled periodically with automatic transmission fluid (Type A). Under no circumstances should a heavy oil be used. Unscrew reservoir cap, withdraw damper, add oil until oil level is 1/4" (7 mm) above top of hollow piston rod.

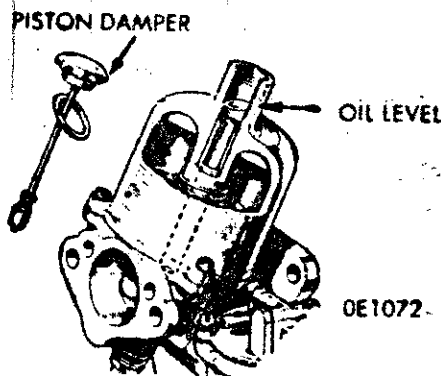

CARBURETOR LUBRICATION

MULTIPLE CARBURETOR LINKAGE LUBRICATION

Periodically lubricate moving parts of linkage with a light viscosity oil (engine oil of same weight as used to lubricate carburetor damper reservoir).

AIR CLEANERS

Follow vehicle manufacturers recommendations for proper mileage intervals for cleaning or replacing air cleaner.

S.U. Carburetors

H.S. & H.D. TYPE 1-BARREL

in America (1968-70)
 Austin Healey 3000 (1962-67)
 Austin Healey Sprite (1962-69)
 Jaguar (1962-70)
 MG 1100 (1968-70)
 MGB (1962-70)
 MGC (1969)
 MG Midget (1968-70)
 Rover 2000 (1963-69)
 Rover 3500S (1970)
 Triumph Spitfire (1963-69)
 Triumph TR4 (1962-69)
 Volvo 818 & 20 Engines (1962-70)

DESCRIPTION

Carburetors are of side draft design. Vacuum chamber has a piston which slides up and down, depending on manifold vacuum. Piston is damped by oil filled chamber, which prevents piston from fluctuating too rapidly. Enrichment for cold starting is accomplished by manual choke, which lowers the jet away from its needle to provide richer air/fuel mixture ratio.

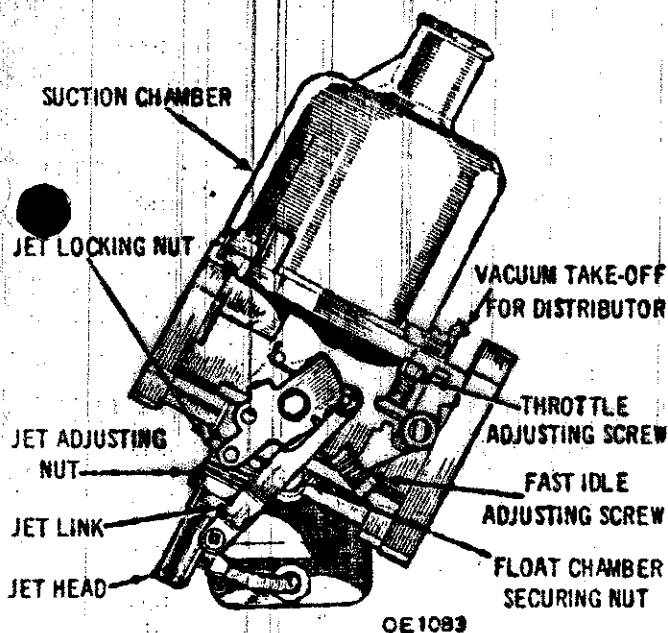

S.U. NON EMISSION TYPE H.S. 4 (OTHERS SIMILAR)

OPERATION

Cold Starting

The jet of each carburetor, located at the bottom of the unit, is lowered through a link system. This system is activated by a choke control on the instrument panel. The fuel needle is tapered, and lowering the jet increases the fuel flow area. The fast idle screw is also contacted by a cam on the carburetor choke lever.

Normal Operation

As the carburetor intake increases in speed when it crosses a constrictive area called the bridge. Fuel from the jet is supplied at this point. Movement of the piston is determined by the amount of vacuum in the intake system. As vacuum increases, the piston rises, allowing greater fuel from the jet, and air from the intake to be admitted to the engine.

Acceleration

The movement of the piston in the suction chamber is damped by a plunger in an oil filled cylinder at the top of the carburetor. This damper prevents the piston from rising too rapidly. This delay or dampening allows fuel from the jet to be mixed with a smaller amount of air than usual, and enriches the mixture. This enriched state is necessary for sudden throttle increase.

Idling

There is no separate idling system as this is accomplished through the normal running system of the carburetor. Due to the up and down movement of the piston in the suction chamber, the air volume is varied continuously. When the engine is at idle, only a small amount of fuel/air mixture passes through the carburetors. The throttle valves are held in a slightly open position by the idle stop screws. The idling of multiple carburetor systems is adjusted independently. The fuel/air mixture is adjusted by adjusting nuts on the jets. These are located at the bottom of the carburetor.

Fast Idle

When the choke lever is pulled out, a lever acts on the jet. This causes the mixture to be enriched. The throttle valve is also influenced by a cam which presses against a fast idle screw. This allows a higher idling RPM as well as a richer mixture. The further the choke control is pulled out, the more rich the mixture, and the higher the idle speed.

Auxiliary Enrichment Carburetor

On some installations of the S.U. Carburetor, an electrical thermostatic carburetor is incorporated. It may be controlled by either a thermostatic or manually operated switch.

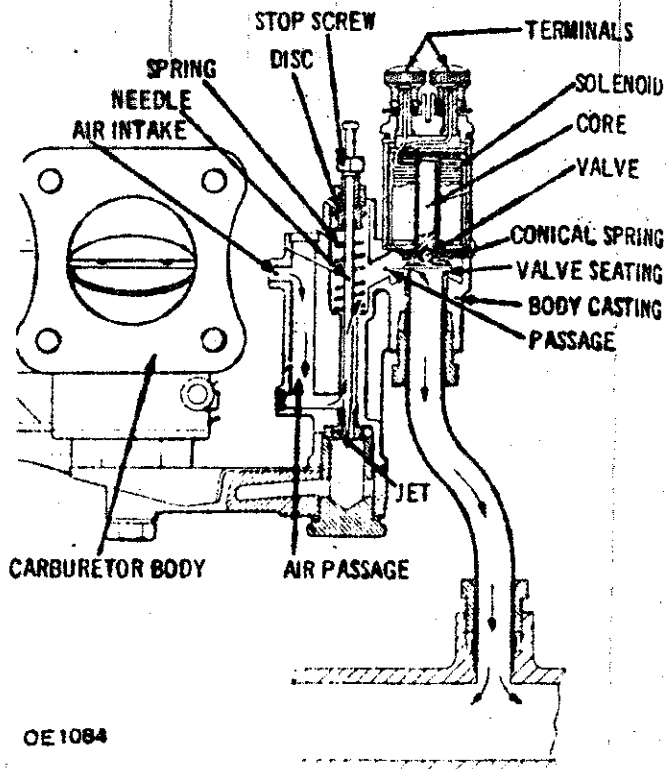

AUXILIARY ENRICHMENT CARBURETOR

H.S. & H.D. TYPE 1-BARREL (Cont.)

When this device is incorporated, the manual choke operation is omitted. Fuel from the float chamber is supplied to the jet and the flow is controlled by a tapered needle in the carburetor. Air is drawn in and mixed with fuel as it passes this jet. The mixture is then carried through a passage past a solenoid operated valve. From here it passes directly to the intake manifold. The device is brought into action by the energizing of a solenoid. When activated, the solenoid opens a disc valve against spring pressure. This uncovers the passage to the intake manifold, and allows the mixture to pass to the engine.

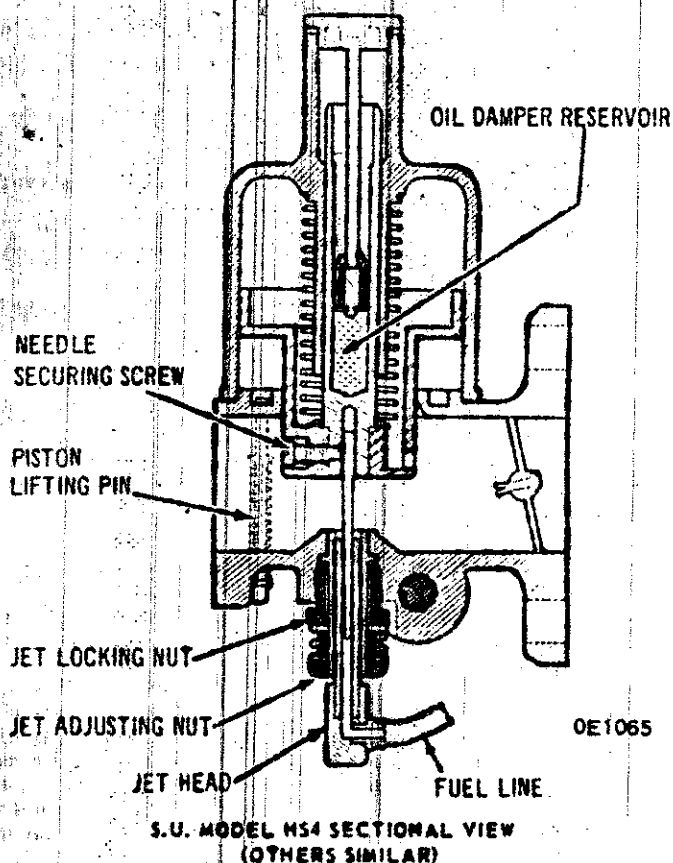

OVERHAUL

Disassembly

Remove carburetors from engine. Remove damper plungers, suction chambers and pistons. Unscrew the float bowl cover and lift it up, remove housing. Loosen screws which retain choke lever and fast idle cam, remove levers and jet. Remove jet adjusting nut, locknut, and jet sleeve. Wash all parts in suitable cleaner and blow dry with compressed air.

Replacing Float Valve

Remove float bowl cover, turn upside down and remove float lever pin and float. Screw out the valve and fit a new valve. Replace float and pin. Refit cover, making sure that gasket is in good condition.

Replacing Needle

Remove piston and suction chamber assembly. Loosen set screw which holds the needle in place. Remove needle. Install a new needle so that shoulder is flush with the base of the piston. Tighten set screw.

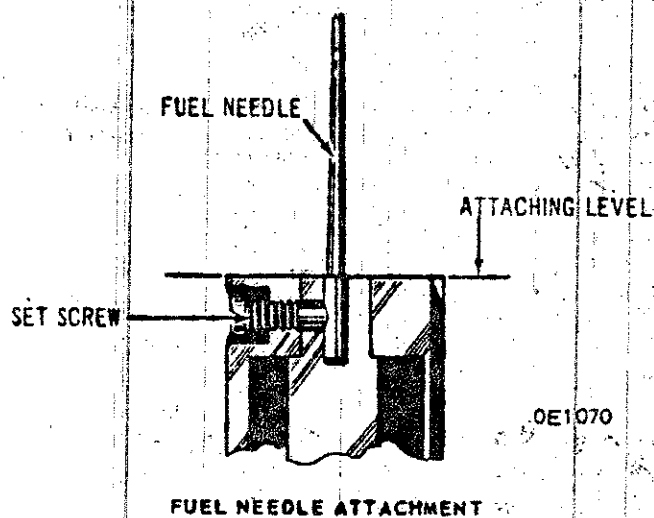

Throttle Spindle Bearings

When new, there is about .0025 in. (.063 mm) clearance between diameter of the spindle and its bearing bores. Any smaller clearance and distortion from engine heat may cause jamming. If wear causes this clearance to increase appreciably, the resulting air leak will alter engine performance. To correct, a new body casting will be needed. As an alternative, the bearing bores may be reamed to oversize and suitable oversize throttle spindle will be required. Any levers or fittings connected to the spindle will also have to be changed to oversize.

Loose Piston Guide Key

If key is riveted type, it can be retightened by lightly riveting over the outer end. Take care not to strike too hard as this may distort the casting in the area of the piston bore.

Throttle Valve Assembly

Turn throttle spindle so that the slot is in line with the main bore. Slide the valve into place. Turn the spindle until the throttle is closed and adjust until the holes in the valve match up with those in the spindle. Insert the attaching screws in these holes but do not tighten. Open throttle and close it again with some force. This will exactly center the valve in relation to the throttle bore. Place tension on spindle to hold valve shut and tighten the attaching screws. Hold carburetor up to light to check that throttle valve closes completely and is centered. After tightening screws, open out the split end of the screws a small amount. This will prevent loosening of the screws.

Jet Unit Assembly (Early Type Standard)

Assemble the bottom half jet bearing, its mating copper washer, the jet screw, the jet adjusting nut and its locking spring. By hand, screw up as far as it will go. Then insert the jet upwards into the bottom half bearing and slide one of the small cork glands with its mating brass washer (dished side down) into the bottom of the jet bearing, using the spring to push them there. Drop large-coned metal sealing ring over the jet screw (cone up) and add large cork sealing ring (sometimes rubber). Slide second small brass washer (dished side up) and the second small cork gland. Install the top half bearing and the top copper washer. The complete unit can then be screwed into the carburetor casting finger tight. Jet must be centered before it is tightened. See "Centering the Jet" in this section.

S.U. Carburetors

H.S. & H.D. TYPE 1-BARREL (Cont.)

E - There are two other types of jet assemblies, the "Thermo" jet and the "Invicta" jet. They differ only slightly from the standard jet.

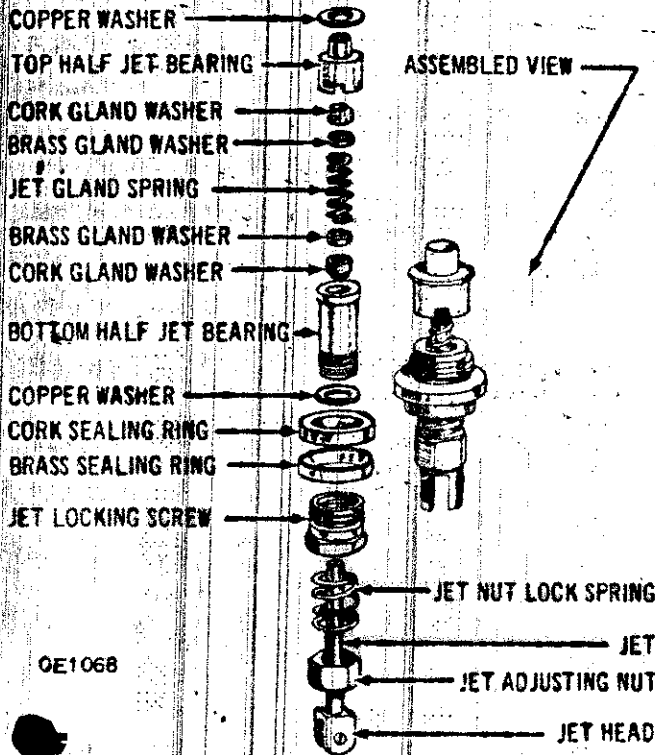

EXPLODED VIEW OF JET (EARLY MODELS)

Jet Unit Assembly (Later Type Standard)

This unit is considerably simplified when compared to the early jets. The early model jets were fed through fuel line passages in the carburetor body, however the later models have a fuel line connected to the bottom of the jet itself. The jet units are not interchangeable although their functions are identical. The later type jet consists of the jet with its fuel line, a jet sleeve and washer, a jet locknut, the adjuster spring, and the adjuster nut. Adjustment of mixture is the same as the early unit.

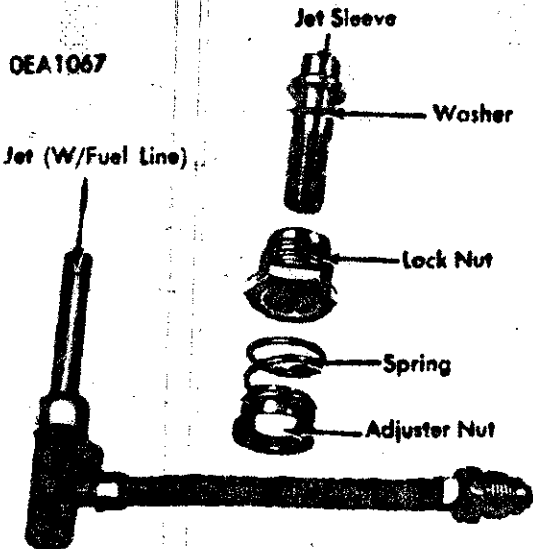

JET DISASSEMBLY (LATE MODELS)

Invicta Jet - This jet has very limited movement and is not lowered, as is the standard jet, for cold starting. Its movement is only sufficient for general mixture strength adjustment. Jet is used only when a separate cold start device is installed.

Thermo Jet - This jet is used in conjunction with the electrically controlled cold starting auxiliary unit. The main difference between this and the standard jet is a much stronger internal spring and no second gland in the lower half jet bearing.

TROUBLE SHOOTING & TESTING

Piston Sticking

The suction disc, piston, and needle all have suitable clearances to prevent sticking. If sticking does occur, the whole assembly should be carefully cleaned and the piston rod should be lubricated with a spot of thin oil. **NOTE** - Do not apply oil to any part except the piston rod. To test for a sticking piston, remove piston damper and lift piston with a pencil or similar instrument. The piston should come up freely and fall freely back on the bridge when released. The piston return spring should not be stretched or increased in tension to improve the rate of piston return.

OE1071

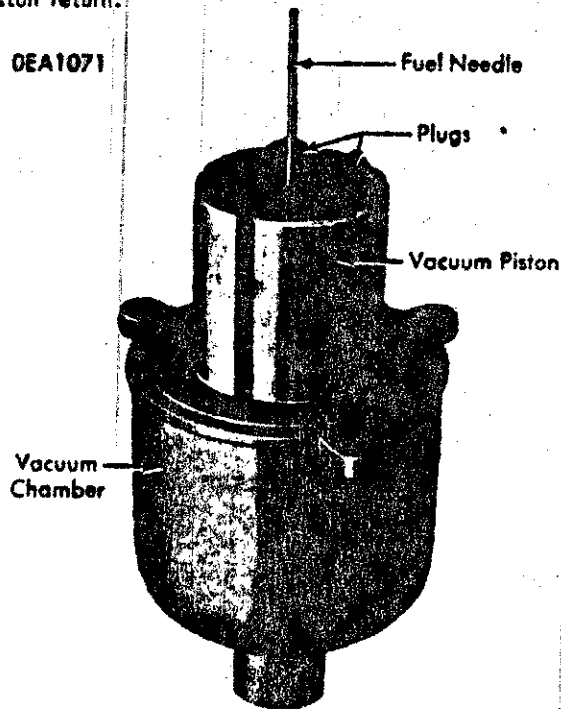

PISTON & SUCTION CHAMBER

Float Chamber Flooding

When fuel flows from the breather hole in the top of the float chamber lid below the main fuel feed pipe, the float bowl is flooding with too much fuel. This is usually caused by dirt between the float chamber needle and its guide. To correct, remove float chamber lid, and clean lid and guide thoroughly.

Float Needle Sticking

If engine stops, seemingly from lack of fuel, although there is fuel in the tank and the fuel pump is working properly, the most usual cause is float needle sticking. Check that fuel is being delivered to the float chamber by removing the fuel line and activating the pump. To correct, remove float chamber lid and thoroughly clean the needle and seating.

S.U. Carburetors

H.S. & H.D. TYPE I-BARREL (Cont.)

consistent with even running. During this adjustment it is necessary to press jets upwards to ensure that they are in contact with the adjusting nuts.

7) As the mixture is adjusted the engine will probably run faster and it may be necessary to unscrew the throttle adjusting screws a little, each by the same amount, to reduce engine speed.

8) Check for proper mixture strength by lifting piston of front carburetor by approximately 1/32 in. (1 mm). If the engine speed momentarily increases very slightly, the mixture of that carburetor is correct.

9) If the engine speed increases, the mixture of that carburetor is too rich; if engine speed immediately decreases, the mixture of that carburetor is too lean.

10) On multi-carburetor system, repeat operation for other carburetors. Recheck each carburetor as the subsequent carburetors are adjusted. When the mixture is correct the exhaust note of the car should be regular and even. If it is irregular with a "splasy" type of misfire and colorless exhaust, the mixture is too lean. If there is a regular or rhythmical type of misfire, with a blackish exhaust, the mixture is too rich.

Fast Idle

Reconnect choke cable and make sure that the jet heads turn against lower face of adjusting nuts when choke control is fully pushed in. Pull out control knob on dash until the linkage is about to move the jets (about 1/4 in.), and adjust fast idle screw to give approximately 1000 RPM when engine is hot.

MAINTENANCE

Carburetor Lubrication

The reservoir on each carburetor must be topped up periodically with light engine oil. Under no circumstances should a heavy lubricant be used. SAE 30 is the heaviest oil that should be used. Unscrew reservoir cap, withdraw damper, add oil until oil level is 1/2 in. (13 mm) above top of hollow piston rod.

PISTON DAMPER

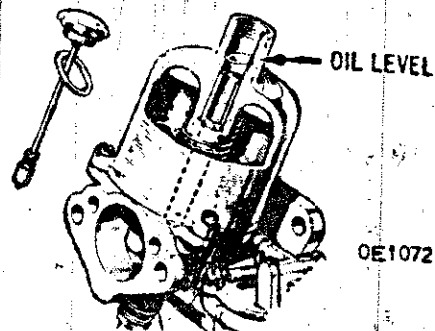

CARBURETOR LUBRICATION

Multiple Carburetor Linkage Lubrication

Periodically lubricate the moving parts of the linkage with a light viscosity oil (engine oil of the same weight as used to lubricate the carburetor damper reservoir).

Air Cleaners

Follow vehicle manufacturers recommendations for proper mileage intervals for either cleaning or replacing the air cleaners.

EXHAUST EMISSION CONTROL FEATURES

H.S. and H.D. carburetors built after 1967 incorporate modifications and features which obtain lower emission values and permit vehicles to conform to government standards. Depending on whether carburetor installation is twin or single, the following listed devices or modifications may be used.

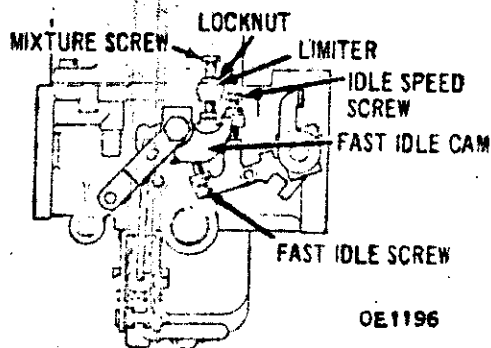

JET ADJUSTMENT LIMITER - TWIN

Jet Adjustment Limiters

Carburetors on both twin and single installations are equipped with a limiting or locking feature on the jet adjustment screws or nuts (see illustrations). The limiters are set at the factory at a point which will permit maximum richness in compliance with emission standards. Adjustment of the jets further can only be made in a leaner direction.

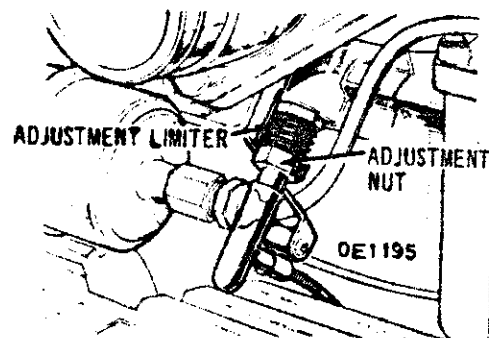

JET ADJUSTMENT LIMITER - SINGLE

H.S. & H.D. TYPE 1-BARREL (Cont.)

Fuel Return System

Due to the relatively small fuel flow from fuel pump to carburetor, especially at low speeds or idling in traffic, the fuel may become overheated by high under-hood temperatures. To prevent such an occurrence, the fuel is kept under a pressure of 3-4 psi and continually circulated between the fuel pump and fuel tank. The carburetor takes fuel from this continuous flow as it is needed.

Fuel Deflector-Device

Deflector consists of a thin metal plate with a punched hole approximately the same diameter as the carburetor bore. The punched hole contains a complete circle of teeth spaced around its inner perimeter (see illustration). The teeth face inward toward the manifold. Purpose of the device is to prevent wet fuel from accumulating on the walls of the manifold. This allows the engine to operate with leaner mixtures.

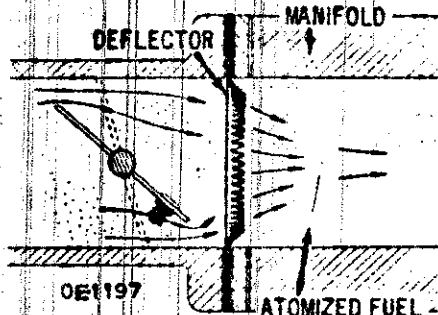

FUEL DEFLECTOR

Poppet Valve (In Throttle Valve)

This small air-operated spring-loaded valve is set in the throttle valve (see illustration). At high intake manifold vacuum (such as engine overrun or coasting with closed throttle), the vacuum overcomes the valve spring to open the valve. With the valve open the normal volume of air/fuel mixture is supplemented, and with a retarded ignition timing setting correct combustion is obtained.

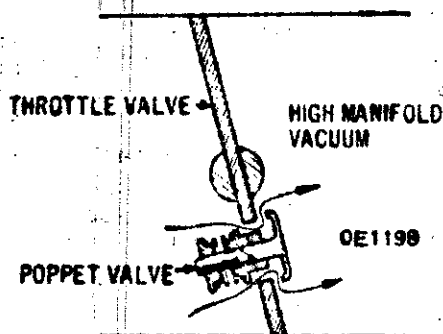

THROTTLE POPPET VALVE

Jet Compensator

Type I - Small bi-metal discs are fitted between each jet assembly and the carburetor body. These discs (see illustration) compensate for changes in air intake temperature, and provide the correct air/fuel ratio to obtain lowered exhaust emission.

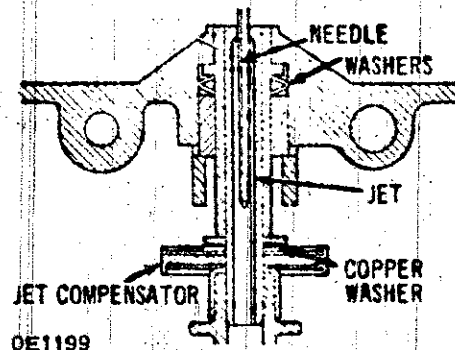

JET COMPENSATOR - TYPE I

Type II - An independently mounted device connected by rubber pipes to the intake manifold below the throttle valve. The compensator contains a bi-metallic valve which is sensitive to air intake temperature and provides an air bleed which by-passes the fuel jet and obtains a leaner mixture at high air intake temperatures (see illustration).

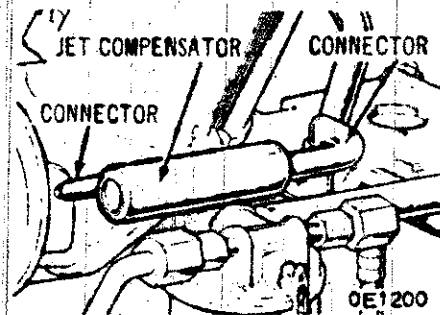

JET COMPENSATOR - TYPE II

Idle Retard Dashpot

A conventional spring and diaphragm type. Acts to prevent throttle valve from snapping completely closed when throttle pedal is completely released while shifting gears on manual transmission equipped vehicles. Effectively controls hydrocarbon emission during gear changes. The device is unnecessary on automatic transmission models since there are no high emissions during gear changes.

Spring-Loaded Needle

Carburetors may be equipped with a spring-loaded needle. The spring is used to maintain the needle in its correct relationship with the carburetor jet, improving the control of emissions (see illustration).

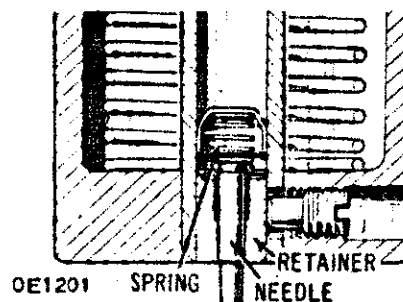

SPRING-LOADED NEEDLE

The Single Progressive Weber Carburetor Conversion Kit

This kit is not a half baked, bolt on, file to fit conversion. It is a highly evolved, tested and proven kit. The carburetor is just a jewel of design and precision. What they say about Weber carbs being the best is true. The DGV was designed to replace the wretched carburetion systems on many small cars. The design objective was good economy, low emissions, good driveability, better power, and throttle response.

These guys scored heavily. It works good, the progressive design means you operate on less than one half of the carburetor until you need power. When you push down on the gas pedal past 40% the other 60% of the carburetor opens up. You can both feel and hear the secondary opening up. If you want to drive for mileage you avoid opening the secondary. If you need power or you can't resist simple pleasures

you punch it in. It is F-U-N. In England they say Volvos don't accelerate, they gain momentum. With the DGV, the cars boogie, and get good mileage. Cold starting is perfect with the manual choke. Especially in cold climates. The linkage kit is high quality roller ball type and easily adjustable. The manifold is cast aluminum, high quality, and fits good.

ONE HALF OF THE CARB STAYS
CLOSED UNTIL YOU NEED
POWER.

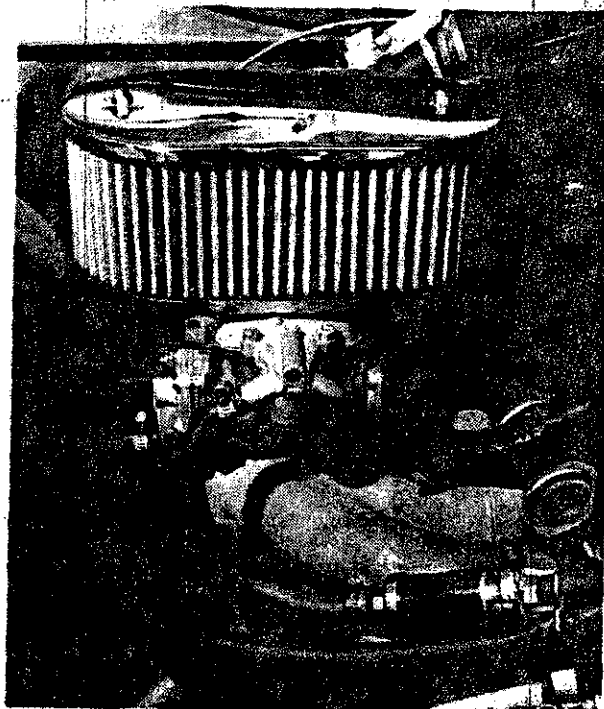
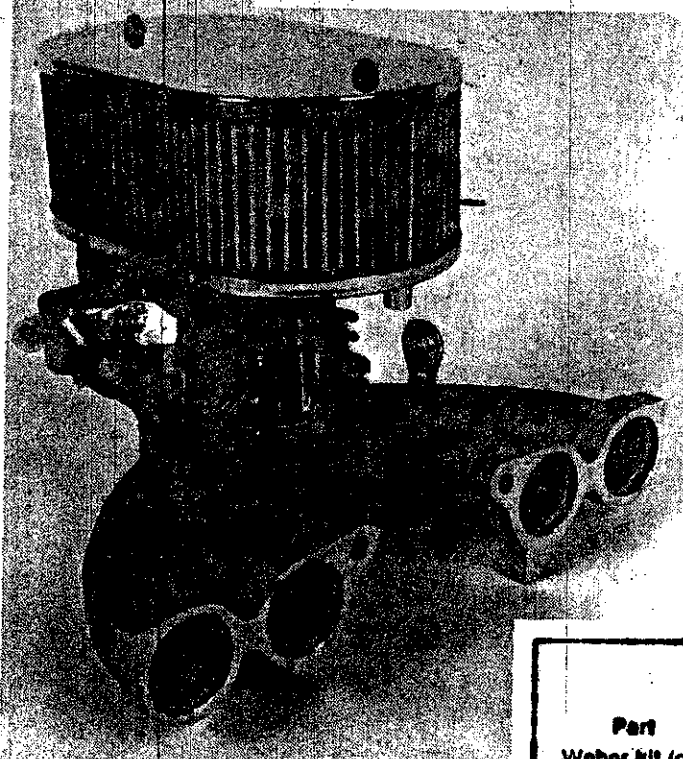

FITS ALL 1800's.

Part	Part Number	File
Weber kit (carb.)	DGV Kit 1	544/1800S/140S 122 62-71

Advantages of the Single Weber Over Sidedraft Carbs

- A. No synchronizing carbs, adjusting mixture, adding oil.
- B. No dangerous fuel overflow.
- C. Steady idle, no loading up at idle, generally eliminates dieseling.
- D. Greatly improved cold starting.
- E. Greatly improved throttle response.
- F. Mileage will equal or exceed best figure obtained from original carbs.
- G. Day in, day out, good running. No more surprises and headaches.

H. Plugs stay clean due to proper running.

The DGV set up also runs much cleaner than the stock carbs. Emissions are much lower and remain consistent. This conversion may or may not meet the emission laws in your state. Generally the dual carb equipped cars are smog exempt because they run so dirty.

Kit includes:

1. Weber 32/36 DGV manual choke carburetor.
2. Large high flow washable K&N air cleaner, with breathe fitting (see page 17 for details). 1 can of air filter oil.

3. High quality cast aluminum manifold with connectors for water heating.

4. Complete linkage kit runs on roller ball connectors. Easily adjustable.

5. Intake/Exhaust manifold gaskets, and header to pipe gasket.

Note: 1967-1971 carbureted cars will require separation of the intake, exhaust manifold. Any machine shop can do this by flame cutting or sawing.

LEGAL IN CALIFORNIA ONLY ON
RACING VEHICLES WHICH MAY
NEVER BE USED ON HIGHWAY.

The World of Carburetion According to SWEDEPARTS

Early model Volvos 1957-1971 were delivered to the American market with twin sidedraft British made carburetors. In Europe the cars were fitted with a single downdraft carburetor. You could write chapters about the different viewpoints between sidedraft and downdraft carburetors. In our experience the following is truth.

1. The SU/Stromberg design is primitive, with no idle circuit and no accelerator pump and a F-U-N-K-Y choke design.
2. The function appears simple it isn't. For them to run good everything must be right, no vacuum leaks, good throttle shafts, right fuel pressure, in synch, right needles, jets, and oil.
3. When the SU's/Stromberg wear out they cause a multitude of prob-

lems including: Overloading at idle; not staying in synch; sticking at very high idle; overflowing fuel causing engine fires; very hard starting, particularly in cold weather; and almost no throttle response.

You guessed it — we no like sidedraft SU/Stromberg set-up.

Downdraft carburetors on the other hand run good, start good, idle good, give good mileage and good throttle response. Volvos like downdraft carburetors. 90% of the headaches experienced in running an older Volvo come from the carburetors. When you get rid of them its like losing a noisy neighbor. The cars just run good, day in and day out. They start and they idle. We are in love with the downdraft carb conversion. Read on.

For those stalwart wizards among you who like the sidedraft carbs we advise that you use a high quality fuel filter to prevent fuel overflowing, and a fuel pressure regulator for the same purpose. Check your throttle shafts for wear, use our new washable K&N air cleaners and carry a fire extinguisher. When the SU's overflow (HS6's) the front one dumps fuel on the generator. If you don't carry a fire extinguisher, carry marshmallows. Try motorcycle shock oil in the dashpots for a little more throttle response. Make sure you get good rebuild kits as most of them on the market are universal kits which are rubbish. (Ours are the real McCoy.) Also, buy the SU or Stromberg book listed on page 18 they are pretty good. Good luck.

WEBER
CARBURATOR!

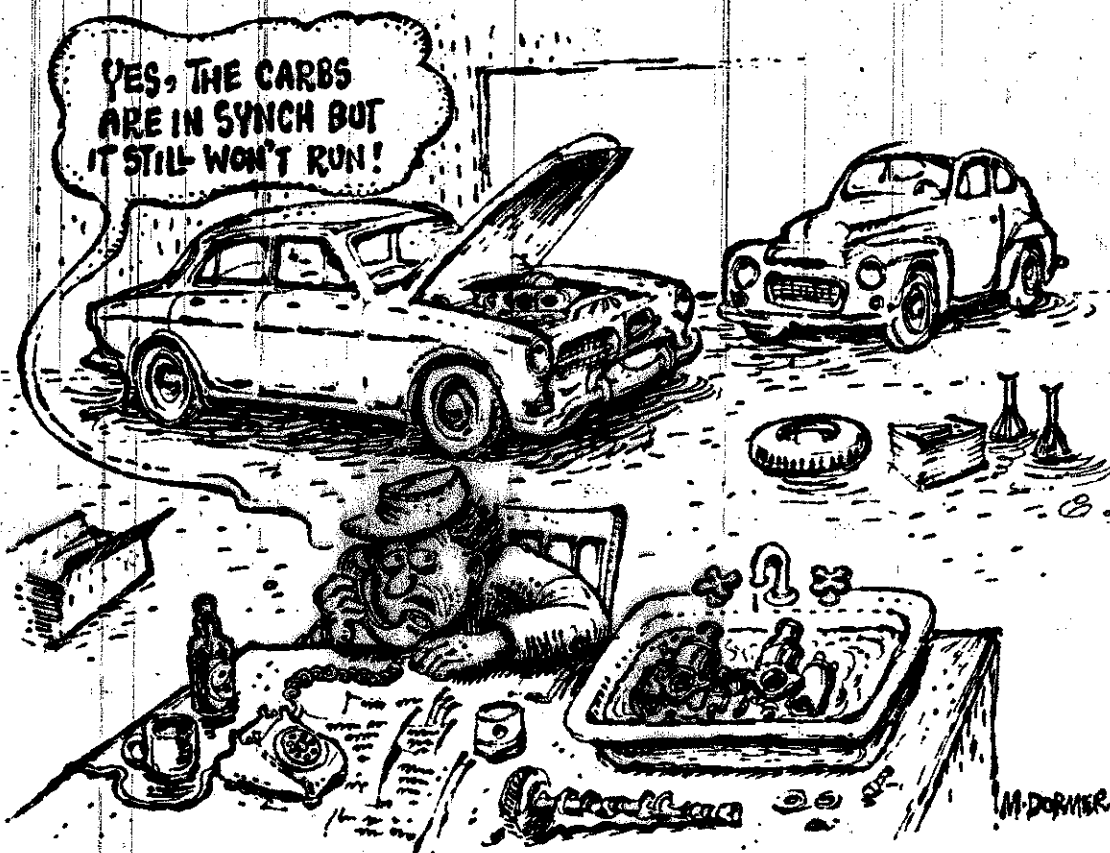

SWEDEPARTS CARBURATOR