

State of California
AIR RESOURCES BOARD

EXECUTIVE ORDER D-154-1
Relating to Exemptions under Section 27156
of the Vehicle Code

POLLUTION CONTROL AUTO PARTS

Pursuant to the authority vested in the Air Resources Board by Section 27156 of the Vehicle Code; and

Pursuant to the authority vested in the undersigned by Sections 39515 and 39516 of the Health and Safety Code and Executive Order G-45-5;

IT IS ORDERED AND RESOLVED: That the installation of the Tank Sentry device model No. 150 manufactured by Pollution Control Auto Parts has been found not to reduce the effectiveness of required motor vehicle pollution control devices and, therefore, is exempt from the prohibitions of Section 27156 of the Vehicle Code for damaged or tampered unleaded fuel fill pipe restrictors on 1975 and newer model-year General Motors Corporation (GMC) and American Motors Corporation (AMC) passenger cars and light-duty trucks with screw-in type filler caps. It is not applicable for replacing original equipment manufacturer (OEM) restrictors which have been completely removed.

This Executive Order is valid provided that installation instructions for this device will not recommend tuning the vehicle to specifications different from those submitted by the device manufacturer.

Changes made to the design or operating conditions of the device, as exempted by the Air Resources Board, that adversely affect the performance of a vehicle's pollution control system shall invalidate this Executive Order.

Marketing of this device using an identification other than that shown in this Executive Order or marketing of this device for an application other than those listed in this Executive Order shall be prohibited unless prior approval is obtained from the Air Resources Board. Exemption of a kit shall not be construed as an exemption to sell, offer for sale, or advertise any component of a kit as an individual device.

This Executive Order does not constitute any opinion as to the effect that the use of this device may have on any warranty either expressed or implied by the vehicle manufacturer.

THIS EXECUTIVE ORDER DOES NOT CONSTITUTE A CERTIFICATION, ACCREDITATION, APPROVAL, OR ANY OTHER TYPE OF ENDORSEMENT BY THE AIR RESOURCES BOARD OF ANY CLAIMS OF THE APPLICANT CONCERNING ANTI-POLLUTION BENEFITS OR ANY ALLEGED BENEFITS OF THE POLLUTION CONTROL AUTO PARTS' TANK SENTRY DEVICE.

No claim of any kind, such as "Approved by Air Resources Board" may be made with respect to the action taken herein in any advertising or other oral or written communication.

Section 17500 of the Business and Professions Code makes untrue or misleading advertising unlawful, and Section 17534 makes violation punishable as a misdemeanor.

Section 43644 of the Health and Safety Code provides as follows:

"43644. (a) No person shall install, sell, offer for sale, or advertise, or, except in an application to the state board for certification of a device, represent, any device as a motor vehicle pollution control device for use on any used motor vehicle unless that device has been certified by the state board. No person shall sell, offer for sale, advertise, or represent any motor vehicle pollution control device as a certified device which, in fact, is not a certified device. Any violation of this subdivision is a misdemeanor."

Any apparent violation of the conditions of this Executive Order will be submitted to the Attorney General of California for such action as he deems advisable.

Executed at El Monte, California, this 14th day of July, 1986.



K. D. Drachand, Chief
Mobile Source Division

State of California
AIR RESOURCES BOARD

EVALUATION OF POLLUTION CONTROL AUTO PARTS' TANK SENTRY DEVICE MODEL 150 FOR
EXEMPTION FROM THE PROHIBITIONS OF VEHICLE CODE SECTION 27156 IN ACCORDANCE
WITH SECTION 2222, TITLE 13, OF THE CALIFORNIA ADMINISTRATIVE CODE

July 1986

July, 1986

State of California
AIR RESOURCES BOARD

Evaluation of Pollution Control Auto Parts' Tank Sentry Device Model 150 for Exemption from the Prohibitions of Vehicle Code Section 27156 in Accordance with Section 2222, Title 13, of the California Administrative Code

by

Mobile Source Division
State of California
Air Resources Board
9528 Telstar Avenue
El Monte, CA 91731

(This report has been reviewed by the staff of the California Air Resources Board and approved for publication. Approval does not signify that the contents necessarily reflect the views and policies of the Air Resources Board, nor does mention of trade names or commercial products constitute endorsement or recommendation for use.)

SUMMARY

Pollution Control Auto Parts of 10470 Grey Cloud Trail South, Cottage Grove, Minnesota 55016, has applied for exemption from the prohibitions of California Vehicle Code Section 27156 for its model 150 Tank Sentry device, to be used for repairing damaged or tampered unleaded fuel fill pipe restrictors on catalyst equipped California-certified General Motors Corporation (GMC) and American Motors Corporation (AMC) passenger cars and light-duty trucks with screw-in type filler caps. It is only applicable for replacing original equipment manufacturer (OEM) device where remains of the OEM restrictor exist. Section 27156 prohibits modifications to emission controlled vehicles which cause a reduction in the effectiveness of the vehicle's emission control systems.

The applicant submitted the specifications of the model 150 device and four (4) samples of the device, one of which was installed in a fill pipe.

The staff evaluated the device in accordance with the Specifications for Fill Pipes and Openings of Motor Vehicle Fuel Tanks. The staff also performed installation experiments and bench tests to determine the durability of the device. Based on the obtained results, the staff concludes that the model 150 Tank Sentry device meets the exemption requirements for installation on specified GMC and AMC passenger cars and light-duty trucks.

The staff recommends that the Pollution Control Auto Parts be granted an exemption from the prohibitions in California Vehicle Code Section 27156 for their model 150 Tank Sentry device and that Executive Order D-154-1 be issued.

TABLE OF CONTENTS

	<u>Page No.</u>
SUMMARY	i
CONTENTS	ii
I. INTRODUCTION	1
II. CONCLUSION	1
III. RECOMMENDATION	1
IV. DEVICE DESCRIPTION	2
V. DEVICE EVALUATION	2
VI. DISCUSSION	4
VII. APPENDICES	5
APPENDIX A Drawings and Specifications of model 150 of the Tank Sentry Device	6
APPENDIX B Installation Instructions	11
APPENDIX C New Pollution Control Product Release	12

EVALUATION OF POLLUTION CONTROL AUTO PARTS' TANK SENTRY DEVICE MODEL 150 FOR EXEMPTION FROM THE PROHIBITIONS OF VEHICLE CODE SECTION 27156 IN ACCORDANCE WITH SECTION 2222, TITLE 13, OF THE CALIFORNIA ADMINISTRATIVE CODE

I. INTRODUCTION

Pollution Control Auto Parts of 10470 Grey Cloud Trail South, Cottage Grove, Minnesota 55016, has applied for exemption from the prohibitions of California Vehicle Code Section 27156 for its model 150 Tank Sentry device. This device is designed to replace the damaged or tampered OEM unleaded fuel fill pipe restrictors on catalyst equipped GMC and AMC passenger cars and light-duty trucks with screw-in type filler caps. It is only applicable for replacing OEM device where remains of the OEM restrictor exist. Section 27156 prohibits modifications to required vehicle emission control systems.

Exemptions to the Section are granted upon demonstration that the device does not increase emissions or reduces the effectiveness of the required emission control systems of applicable vehicles.

The applicant submitted four samples, one of which was installed in a fill pipe, for our inspection and evaluation. The applicant also submitted drawings and specifications of the device for evaluation.

II. CONCLUSION

Based on the detailed studies of the design, installation experiments and bench tests to determine durability of the device, the staff concludes that the model 150 Tank Sentry device meets the Vehicle Code Section 27156 requirements for exemption, for installation on specified GMC and AMC vehicles.

III. RECOMMENDATION

The staff recommends that the Pollution Control Auto Parts be granted an exemption from the prohibitions of California Vehicle Code Section 27156 for their model 150 Tank Sentry device, for installation on certain 1975 and newer GMC and AMC passenger cars and light-duty trucks with screw-in type filler caps and Executive Order D-154-1 be issued.

IV. DEVICE DESCRIPTION

The Pollution Control Auto Parts' Tank Sentry device model 150 is an unleaded fuel fill pipe restrictor designed to replace damaged or tampered OEM restrictors. The model 150 restrictor fits into a fill pipe with screw-in filler caps on GMC and AMC passenger cars and light-duty trucks. It is not applicable for replacing OEM restrictors which have been completely removed because it will then fall through the fill pipe into the tank.

The device is made of 0.028 inch sheet metal (see Appendix A for drawings and specifications of the device). The device has a 0.915 inch diameter filling hole for passing the nozzle to the required depth in the fill pipe. This filling hole has an eccentricity of .230" with respect to the centerline of the fill pipe neck. The overall diameter of the device is 1.95 inches. The diameter of the device where the teeth have been removed is 1.56 inches. Attached to the hind side of the device is a spring loaded 0.028 inch thick flapper door which covers the filling hole and is maintained in the closed position. Executive Order No. D-154-1 and the company's name "PCAP" will be imprinted on the front side of the flapper door.

The device has twelve (12) sharp teeth, seven of which are longer and less spaced and located on the far side of the inner hole (near the spring) and five of which are located on the near side of inner hole. The teeth allow the device to be pushed into the fill pipe and to sit on top of the remains of the OEM restrictor.

According to the installation instructions (see Appendix B), the device can be installed without removing the gas tank or gas filler tube from the vehicle. Once installed it can not be removed since the teeth are all bent upward and the device is squeezed tightly against the fill pipe wall.

V. DEVICE EVALUATION

The device was evaluated for its: 1) ability to restrict leaded fuel nozzles; 2) compliance with the Specifications for Fill Pipe and Openings of Motor Vehicle Fuel Tanks, and 3) durability.

The filling hole diameter of the device is 0.915 inches for passing the unleaded fuel nozzle but restricting the insertion of a leaded fuel nozzle. There are openings between the teeth around the circumference of the device when installed. The openings are not large enough to allow misfueling.

According to the Specification for Fill Pipes and Openings of Motor Vehicle Fuel Tanks, "angle alpha" is the angle between the axial centerline of the fill pipe face and the axial centerline of the test nozzle spout when in its normal resting position. This angle should fall within the range of - 10° and 20° and the penetration of the test fuel nozzle in the fill pipe should be at least 2.25 centimeters. After a review of the company's installation instructions, the staff is of the opinion that the Tank Sentry device, model 150, when installed properly will meet the above requirements. The Tank Sentry device is only applicable for replacing OEM device where remains of the OEM restrictor exist.

The submitted sample of the device was installed in a GMC fill pipe with a screw-in type filler cap. The fill pipe was clamped in a vice and tested for durability. The durability test consisted of inserting and removing an unleaded fuel nozzle through the device repeatedly, with an effort to dislocate the restrictor. The restrictor remained in its place during the entire test of simulated filling operation.

Based on the above, the staff concludes that if the device is installed correctly it will function the same as an OEM restrictor and it meets the requirements for exemption from the prohibitions of California Vehicle Code Section 27156.

VI. DISCUSSION

Pollution Control Auto Parts of Minnesota, has applied for exemption from the prohibitions in California Vehicle Code Section 27156 for the model 150 Tank Sentry device. The device is designed to replace damaged or tampered OEM fuel fill pipe restrictors in fuel fill pipes with screw-in type filler caps on 1975 and newer catalyst equipped GMC and AMC passenger cars and light-duty trucks.

Pollution Control Auto Parts previously applied for exemption for their model 278 Tank Sentry device for Ford vehicles with stepped-in diameter fill pipes. The model 278 was exempted from the prohibitions of the California Vehicle Code Section 27156 under E.O. D-154. The model 150 is identical to the model 278 except for the removal of the side teeth, two on each side. The removal of the side teeth has made the diameter of the model 150 smaller than the model 278 in order to allow the device to pass through the threaded part of the fill pipe and facilitate its installation. The Tank Sentry device is not applicable for replacing OEM restrictors which have been completely removed because it is necessary that remains of OEM restrictor exist for supporting the device and preventing it from falling through the fill pipe into the tank.

The staff is of the opinion that the new model 150 of the Tank Sentry device meets the requirements for exemption from the prohibitions of Vehicle Code Section 27156 for the specified GMC and AMC passenger cars and light-duty trucks. The staff recommends that Executive Order D-154-1 be issued.

Appendices

Page No.

APPENDIX A

6

APPENDIX B

11

APPENDIX C

12

Drawings and Specifications of
Model 150 of the Tank Sentry Device

SECT A-A

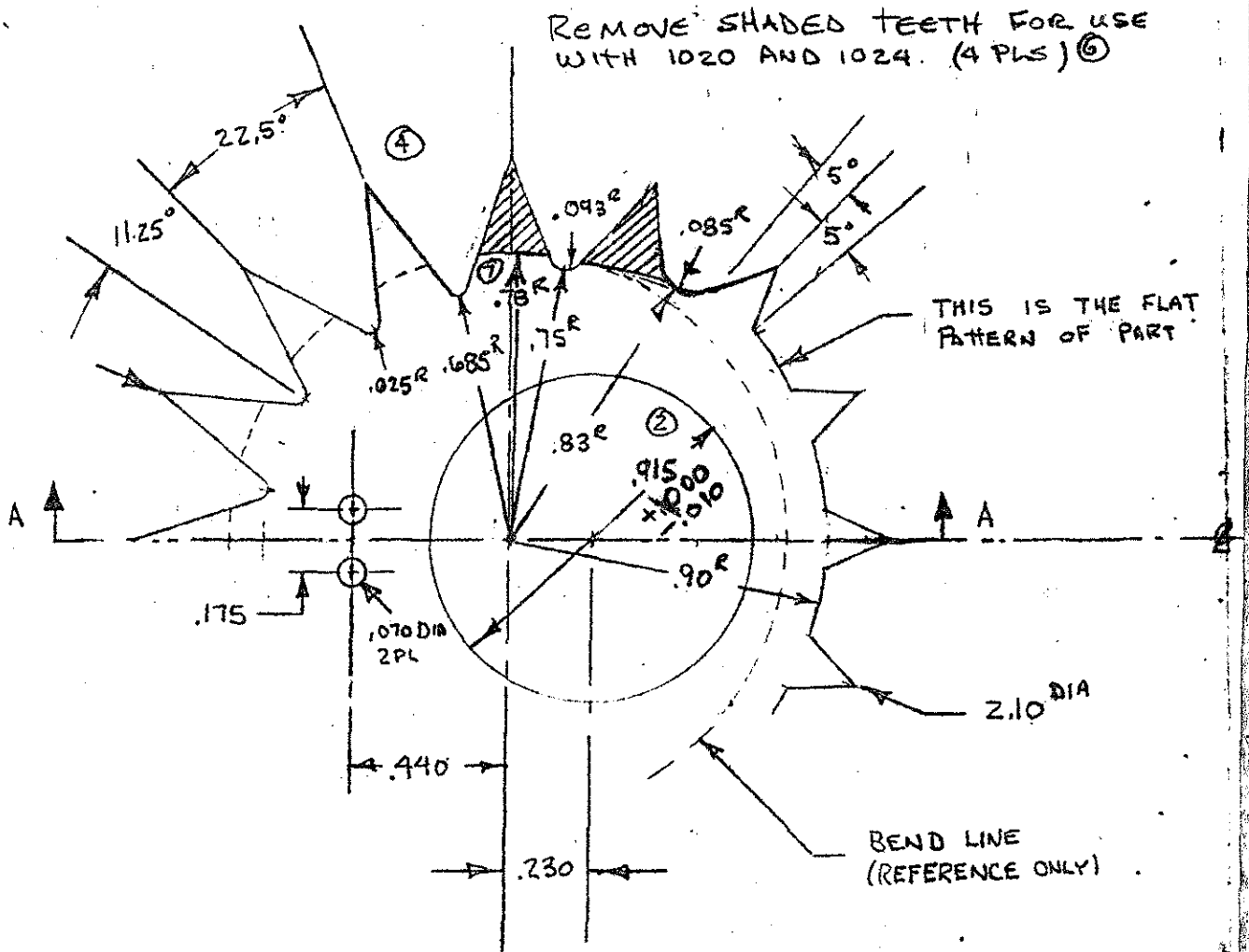
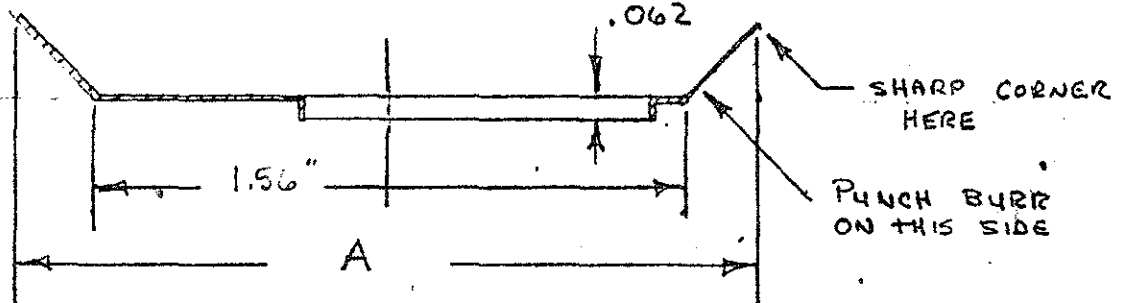

(3) FI
HEAT TREAT SEE
PRINTS 1020, 1024, 1016, 1017
SPRING TEMPER

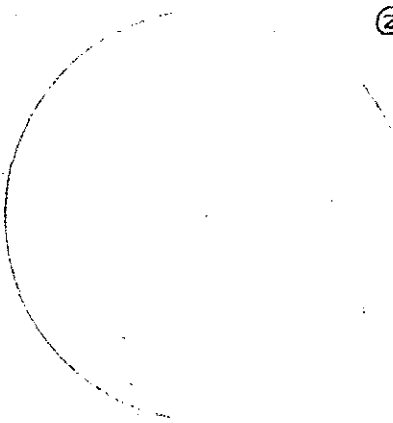

ACTUAL ENVELOPE OF FLAT PATTERN

- ① MATERIAL THICKNESS CHANGED FROM .018 to .022-.028 10-31-85
- ② TOLERANCE ADDITION ±.000 - .010 10-31-85
- ③ CHANGE MATL THICKNESS to .028
- ④ ADD ALTERNATE Profile for P/N 1020, 1024
- ⑤ CHANGE HEAT TREAT to BS SPECIFIC ON 1016, 1020 1024 6-3-86
- ⑥ ADD 4 PLS 6/12/86
- ⑦ ADDED .78^R DIM FOR CHARIFICATION 6/27/86

① ③

MATERIAL 1075 THICKNESS .028 ± .002
 BASED ON 1020, 1024, 1016

sh: BLACK OXIDE AND OIL

TITLE:	
TANK SENTRY BLANK WITH LIP	
DR LAK 9/22/85	PART NUMBER
CK	
SCALE: 1" = 1/2"	M-DOC 1014-O REUD

SCALE		ANGULAR DIM.		WELDING		MACHINING		OPERATION	
±		±		±.1 ±.08		±.1 ±.02		PLACES IN DIMENSION	
±		±		±		±.04		MAXIMUM SURFACE ROUGHNESS	
±		±		±		±.005		ROUGHNESS	
±		±		±		±.02		MAXIMUM SURFACE ROUGHNESS	
±		±		±		±.04		MAXIMUM SURFACE ROUGHNESS	
±		±		±		±.02		MAXIMUM SURFACE ROUGHNESS	
±		±		±		±.005		MAXIMUM SURFACE ROUGHNESS	
±		±		±		±.02		MAXIMUM SURFACE ROUGHNESS	
±		±		±		±.04		MAXIMUM SURFACE ROUGHNESS	
±		±		±		±.02		MAXIMUM SURFACE ROUGHNESS	
±		±		±		±.005		MAXIMUM SURFACE ROUGHNESS	

TOLERANCE AND SURFACE ROUGHNESS UNLESS NOTED

ISSUE	ISSUE DATE AND CHANGE RECORD	REV.	CHG.
-------	------------------------------	------	------

USED ON

ISSUE	ISSUE DATE AND CHANGE RECORD	REV.	CHG.

#150
 SETTER WITH TIP
 AND FLAPPER FOR
 G.M. ; HMC "SCREW IN TYPE"

PART NO.
 M-DOC 1024
 Rev B

A

ORIGINAL PRINT
 Appendix A (continued)

USE PART NUMBER M-DOC 1014-D-PRINT
 "A" DIMENSION = 1.95
 HEAT TREAT RC46-48 W/ .028 THICK MATERIAL

APPENDIX A
Continued

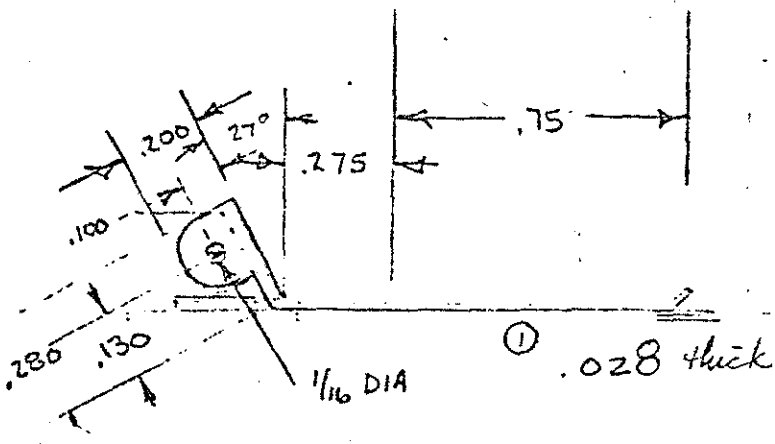
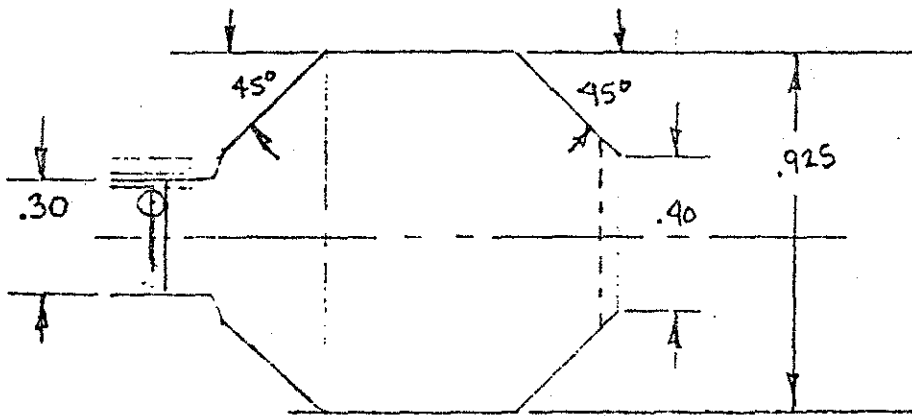

① PIN M.DOC 1012-0
FLAP.

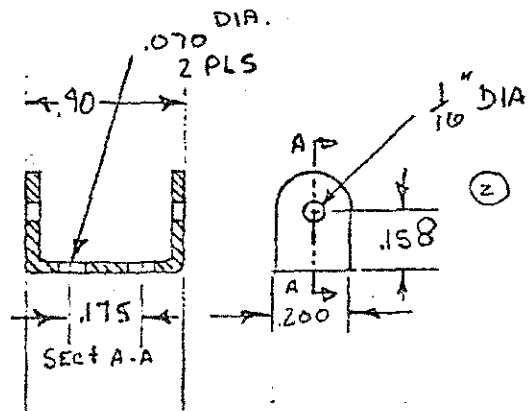

② PIN M.DOC 1013-0
U-BRACKET

9. MATERIAL 300 SERIES
STAINLESS STEEL

APPENDIX A
Continued

① CHANGED FROM .020
.028 10-31-E

② CHANGED FROM .150
.158 10-31-

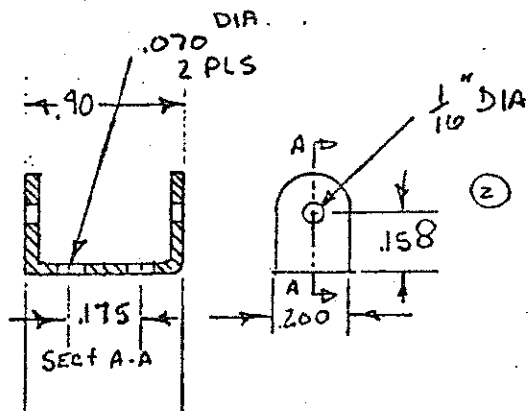
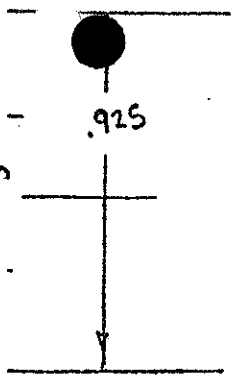

P/N M DDC 1013-0
U-BRACKET

MATERIAL 300 SERIES
STAINLESS STEEL

FLAPPER SPRING ASSY
SCALE = 2X

7/21/85
LAK

Tank Sentry With Flapper Installation/Instruction Sheet

The tank sentry is a convenient, quick and inexpensive way to repair damaged or tampered unleaded gas filler tube restrictors.

The tank sentry can be inserted without removing the gas tank or gas filler tube from the car with a hammer blow to a suitable sized socket or dowel driving restrictor into place.

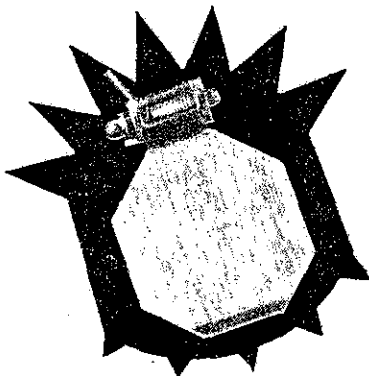

Tank Sentry with Flapper

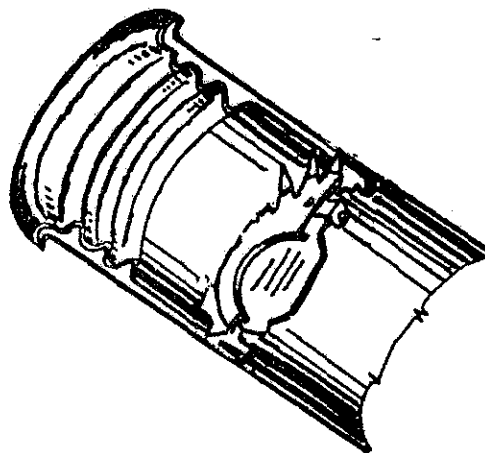

Typical Installation

Position #150 Tank Sentry with 5 teeth at *bottom* of filler pipe (7 at top) for installation. Insert 5 teeth section past the threads at a 45° angle into the neck directly on *top* of the existing lip of original equipment section. The 7 teeth will, at this point, be resting on top of the threads. After proper positioning, drive into place using a suitably sized socket or dowel against the top seven teeth, but below the bend line.

CAUTION: Make sure tampered hole is large enough to accept Tank Sentry with Flapper prior to installation. If the new hole does not align properly use a screwdriver or suitable tool to rotate the Tank Sentry so filler holes do align.

NOTE: The Tank Sentry MUST be in alignment with the former restrictor hole and as close as possible in depth to original restrictor to be in compliance. If the former hole does not exist or is greatly enlarged, the Tank Sentry should always be installed so that the offset filler hole is positioned toward the bottom of the filler pipe.

Limitations

- All makes & models where tampering is so extensive that the Original Equipment Restrictor metal has been completely removed or any filler pipe with an inside diameter of more than 1.950 inches.
- All Ford Motor Co. vehicles. (Use our Part #278 for Ford vehicles with "stepped" double flange on inside of tube.)

★ ★ NEW POLLUTION CONTROL PRODUCT RELEASE ★ ★

Unleaded Gas Inlet Restrictor For Existing Gas Filler Tubes

Sensible approach to preventing the use of regular gasoline. Reduces nozzle size opening to unleaded only. Repair damaged or tampered unleaded gas tank filler tube restrictor quickly and inexpensively.

- Can be inserted without removing the gas tank or gas filler tube from car with a hammer blow to a suitably sized socket or dowel driving the restrictor into place.
- Eliminates the necessity of replacing the entire gas tank and neck on those General Motors vehicles having a one piece assembly. Save \$50 to \$200.

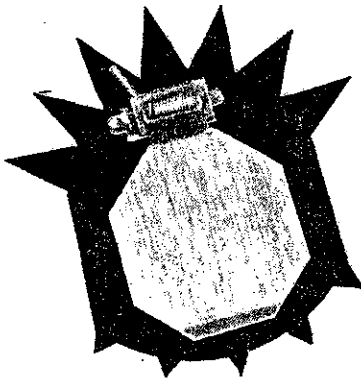

Patent Pending
Serial Number
669,379

#150 Tank Sentry with Flapper—Fits all General Motor and AMC vehicles with "screw in" type fuel filler caps

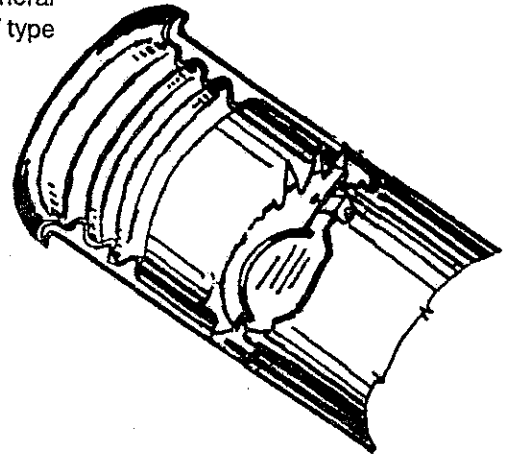

Typical Installation

- Passes emission inspections—makes cars legal
- Simple to obtain and keep in stock
- Satisfaction moneyback guarantee
- Installation instructions provided
- No special tools required
- Tamper proof

CALL TOLL FREE (DIAL ALL NUMBERS) 1-800/525-0016 WAIT FOR TONE 687314

POLLUTION CONTROL AUTO PARTS 10470 Grey Cloud Trail South • Cottage Grove, MN 55016

----- Tear Off Here and Mail -----

**To Speed Your Order
CALL TOLL FREE**

(Dial All Numbers Below)

1-800/525-0016 Pause 687314

SHIP TO	
Phone Number	
Firm Name	
Attention	
Street Address	
City	Zip

How Many?	Part Number	Description	Unit Price	Total Price
	#150	Tank Sentry with Flapper	\$11.40 Each	