

State of California
AIR RESOURCES BOARD

EXECUTIVE ORDER D-154-3
Relating to Exemptions under Section 27156
of the Vehicle Code

POLLUTION CONTROL AUTO PARTS

Pursuant to the authority vested in the Air Resources Board by Section 27156 of the Vehicle Code; and

Pursuant to the authority vested in the undersigned by Sections 39515 and 39516 of the Health and Safety Code and Executive Order G-45-5;

IT IS ORDERED AND RESOLVED: That the installation of the model #150 Tank Sentry device manufactured by Pollution Control Auto Parts has been found not to reduce the effectiveness of required motor vehicle pollution control devices and, therefore, is exempt from the prohibitions of Section 27156 of the Vehicle Code for replacing damaged or tampered unleaded fuel filler pipe restrictors on specified Chrysler Corporation passenger cars and light-duty trucks with screw-in type and twist-on type filler caps and Ford Motor Company passenger cars and light-duty trucks with screw-in type filler caps only. It is not applicable for replacing original equipment manufacturer (OEM) restrictors which have been completely removed.

This Executive Order is valid provided that installation instructions for this device will not recommend tuning the vehicle to specifications different from those submitted by the device manufacturer.

Changes made to the design or operating conditions of the device, as exempted by the Air Resources Board, that adversely affect the performance of a vehicle's pollution control system shall invalidate this Executive Order.

Marketing of this device using an identification other than that shown in this Executive Order or marketing of this device for an application other than those listed in this Executive Order shall be prohibited unless prior approval is obtained from the Air Resources Board. Exemption of a kit shall not be construed as an exemption to sell, offer for sale, or advertise any component of a kit as an individual device.

This Executive Order does not constitute any opinion as to the effect that the use of this device may have on any warranty either expressed or implied by the vehicle manufacturer.

THIS EXECUTIVE ORDER DOES NOT CONSTITUTE A CERTIFICATION, ACCREDITATION, APPROVAL, OR ANY OTHER TYPE OF ENDORSEMENT BY THE AIR RESOURCES BOARD OF ANY CLAIMS OF THE APPLICANT CONCERNING ANTI-POLLUTION BENEFITS OR ANY ALLEGED BENEFITS OF THE POLLUTION CONTROL AUTO PARTS TANK SENTRY DEVICE.

No claim of any kind, such as "Approved by Air Resources Board" may be made with respect to the action taken herein in any advertising or other oral or written communication.

Section 17500 of the Business and Professions Code makes untrue or misleading advertising unlawful, and Section 17534 makes violation punishable as a misdemeanor.

Section 43644 of the Health and Safety Code provides as follows:

"43644. (a) No person shall install, sell, offer for sale, or advertise, or, except in an application to the state board for certification of a device, represent, any device as a motor vehicle pollution control device for use on any used motor vehicle unless that device has been certified by the state board. No person shall sell, offer for sale, advertise, or represent any motor vehicle pollution control device as a certified device which, in fact, is not a certified device. Any violation of this subdivision is a misdemeanor."

Any apparent violation of the conditions of this Executive Order will be submitted to the Attorney General of California for such action as he deems advisable.

Executed at El Monte, California, this 2nd day of February, 1987.

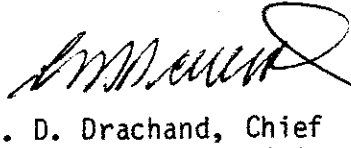
K. D. Drachand, Chief
Mobile Source Division

State of California
AIR RESOURCES BOARD

EVALUATION OF POLLUTION CONTROL AUTO PARTS' MODEL #150 TANK SENTRY DEVICE FOR
EXEMPTION FROM THE PROHIBITIONS OF VEHICLE CODE SECTION 27156 IN ACCORDANCE
WITH SECTION 2222, TITLE 13, OF THE CALIFORNIA ADMINISTRATIVE CODE

January 1987

January, 1987

State of California
AIR RESOURCES BOARD

Evaluation of Pollution Control Auto Parts' Model #150 Tank Sentry Device for
Exemption from the Prohibitions of Vehicle Code Section 27156 in Accordance
with Section 2222, Title 13, of the California Administrative Code

by

Mobile Source Division
State of California
Air Resources Board
9528 Telstar Avenue
El Monte, CA 91731

(This report has been reviewed by the staff of the California Air Resources Board and approved for publication. Approval does not signify that the contents necessarily reflect the views and policies of the Air Resources Board, nor does mention of trade names or commercial products constitute endorsement or recommendation for use.)

SUMMARY

Pollution Control Auto Parts of 10470 Grey Cloud Trail South, Cottage Grove, Minnesota 55016, has applied for exemption from the prohibitions of California Vehicle Code (V.C.) Section 27156 for its model #150 Tank Sentry device, which is to be used for replacing damaged or tampered unleaded fuel fill pipe restrictors on catalyst equipped Ford Motor Company passenger cars and light-duty trucks with screw-in filler caps and on Chrysler Corporation passenger cars and light-duty trucks with both screw-in and twist-on caps. It is only applicable for replacing original equipment manufacturer (OEM) device where remains of the OEM restrictor exist. V.C. Section 27156 prohibits modifications to emission controlled vehicles which cause a reduction in the effectiveness of the vehicle's emission control systems.

The applicant submitted samples of the device for examination and evaluation. The staff evaluated the device in accordance with the ARB's Specifications for fuel Fill Pipes and Openings of Motor Vehicle Fuel Tanks. The staff also performed installation experiments and bench tests to determine the durability of the device. Based on the obtained results, the staff concludes that the model #150 Tank Sentry device meets the exemption requirements for installation on specified Chrysler and Ford passenger cars and light-duty trucks.

The staff recommends that the Pollution Control Auto Parts be granted an exemption from the prohibitions in California Vehicle Code Section 27156 for their model #150 Tank Sentry device and that Executive Order D-154-3 be issued.

TABLE OF CONTENTS

	<u>Page No.</u>
SUMMARY	i
CONTENTS	ii
I. INTRODUCTION	1
II. CONCLUSION	1
III. RECOMMENDATION	1
IV. DEVICE DESCRIPTION	2
V. DEVICE EVALUATION	3
VI. DISCUSSION	4
VII. APPENDICES	5
APPENDIX A Drawings and Specifications of model 150 of the Tank Sentry Device	6
APPENDIX B Installation Instructions	11
APPENDIX C New Pollution Control Product Release	12

EVALUATION OF POLLUTION CONTROL AUTO PARTS' TANK SENTRY DEVICE MODEL 150 FOR EXEMPTION FROM THE PROHIBITIONS OF VEHICLE CODE SECTION 27156 IN ACCORDANCE WITH SECTION 2222, TITLE 13, OF THE CALIFORNIA ADMINISTRATIVE CODE

I. INTRODUCTION

Pollution Control Auto Parts of 10470 Grey Cloud Trail South, Cottage Grove, Minnesota 55016, has applied for exemption from the prohibitions of California Vehicle Code Section 27156 for its model #150 Tank Sentry device. This device is designed to replace damaged or tampered OEM unleaded fuel fill pipe restrictors on catalyst equipped Chrysler Corporation passenger cars and light-duty trucks with screw-in and twist-on type filler caps and on catalyst-equipped Ford Motor Company passenger cars and light-duty trucks with screw-in type filler caps only. It is only applicable for replacing OEM device where remains of the OEM restrictor exist. Section 27156 prohibits modifications to required vehicle emission control systems. Exemptions to the Section are granted upon demonstration that the device does not increase emissions or reduce the effectiveness of the required emission control systems of applicable vehicles.

II. CONCLUSION

Based on the detailed studies of the design, installation experiments and bench tests to determine durability of the device, the staff concludes that the model #150 Tank Sentry device meets the Vehicle Code Section 27156 requirements for exemption, for installation on specified Chrysler and Ford vehicles.

III. RECOMMENDATION

The staff recommends that Pollution Control Auto Parts be granted an exemption from the prohibitions of California Vehicle Code Section 27156 for their model #150 Tank Sentry device, for installation on specified Chrysler

passenger cars and light-duty trucks with screw-in type and twist-on type filler caps and Ford passenger cars and light-duty trucks with screw-in type filler caps only.

IV. DEVICE DESCRIPTION

The Pollution Control Auto Parts' model #150 Tank Sentry device is an unleaded fuel fill pipe restrictor designed to replace damaged or tampered OEM restrictors. The model #150 restrictor fits into a fuel fill pipe with screw-in filler caps and twist-on caps on Chrysler passenger cars and light-duty trucks; it also fits into a fuel fill pipe with screw-in filler caps on Ford passenger cars and light-duty trucks. It is not applicable for replacing OEM restrictors which have been completely removed; without any support it would fall through the fill pipe into the tank.

The device is made of 0.028 inch sheet metal (see Appendix A for drawings and specifications of the device). The device has a 0.915 inch diameter filling hole for passing the nozzle to the required depth in the fill pipe. This filling hole has an eccentricity of .230" with respect to the centerline of the fill pipe neck. The overall diameter of the device is 1.95 inches. The diameter of the device where the teeth have been removed is 1.56 inches. Attached to the hind side of the device is a spring loaded 0.028 inch thick flapper door which covers the filling hole and is maintained in the closed position. Executive Order No. D-154-3 and the company's name "PCAP" will be imprinted on the front side of the flapper door.

The device has twelve (12) sharp teeth, seven of which are longer and less spaced and located on the far side of the inner hole (near the spring) and five of which are located on the near side of inner hole. The teeth allow the device to be pushed into the fill pipe and to sit on top of the remains of the OEM restrictor.

According to the installation instructions (see Appendix B), the device can be installed without removing the gas tank or gas filler tube from the vehicle. Once installed, it can not be removed since the teeth are all bent upward, and the device is squeezed tightly against the fill pipe wall.

V. DEVICE EVALUATION

The device was evaluated for its: 1) ability to restrict leaded fuel nozzles; 2) compliance with the Specifications for Fill Pipe and Openings of Motor Vehicle Fuel Tanks, and 3) durability.

The filling hole diameter of the device is 0.915 inches for passing the unleaded fuel nozzle but restricting the insertion of a leaded fuel nozzle. There are openings between the teeth around the circumference of the device when installed. The openings are not large enough to allow misfueling.

According to the ARB's Specification for Fill Pipes and Openings of Motor Vehicle Fuel Tanks, "angle alpha" is the angle between the axial centerline of the fill pipe face and the axial centerline of the test nozzle spout when in its normal resting position. This angle should fall within the range of - 10° and 20°, and the penetration of the test fuel nozzle in the fill pipe should be at least 2.25 centimeters. After a review of the company's installation instructions, the staff is of the opinion that model #150 Tank Sentry device when installed properly will meet the above requirements. The Tank Sentry device is only applicable for replacing OEM device where remains of the OEM restrictor exist.

The submitted samples of the device were installed in Chrysler fill pipes with a screw-in type filler cap and twist-on type filler cap; also, one of the samples was installed in a Ford fill pipe with screw-in type filler cap. The fill pipes were clamped in a vice and tested for durability. The durability test consisted of inserting and removing an unleaded fuel nozzle

through the device repeatedly, with an effort to dislocate the restrictor. The restrictor remained in its place during the entire test of simulated filling operation.

Based on the above, the staff concludes that if the device is installed correctly it will function the same as an OEM restrictor, and it meets the requirements for exemption from the prohibitions of California Vehicle Code Section 27156.

VI. DISCUSSION

Pollution Control Auto Parts of Minnesota, has applied for exemption from the prohibitions in California Vehicle Code Section 27156 for the model #150 Tank Sentry device for use on specified Chrysler and Ford vehicles. The model #150 had been exempted from the prohibitions of the California Vehicle Code Section 27156 under E.O. D-154-1 for specified GMC and AMC vehicles. The model #150 Tank Sentry device was found also to fit on specified Chrysler and Ford vehicles. However, this device is not applicable for replacing OEM restrictors which have been completely removed; without any support it would fall through the fill pipe into the tank.

The staff is of the opinion that the model #150 Tank Sentry device meets the requirements for exemption from the prohibitions of Vehicle Code Section 27156 for the installation on specified Chrysler and Ford passenger cars and light-duty trucks. The staff recommends that Executive Order D-154-3 be issued.

Appendices

Page No.

APPENDIX A

6

APPENDIX B

11

APPENDIX C

12

Drawings and Specifications of
Model 150 of the Tank Sentry Device

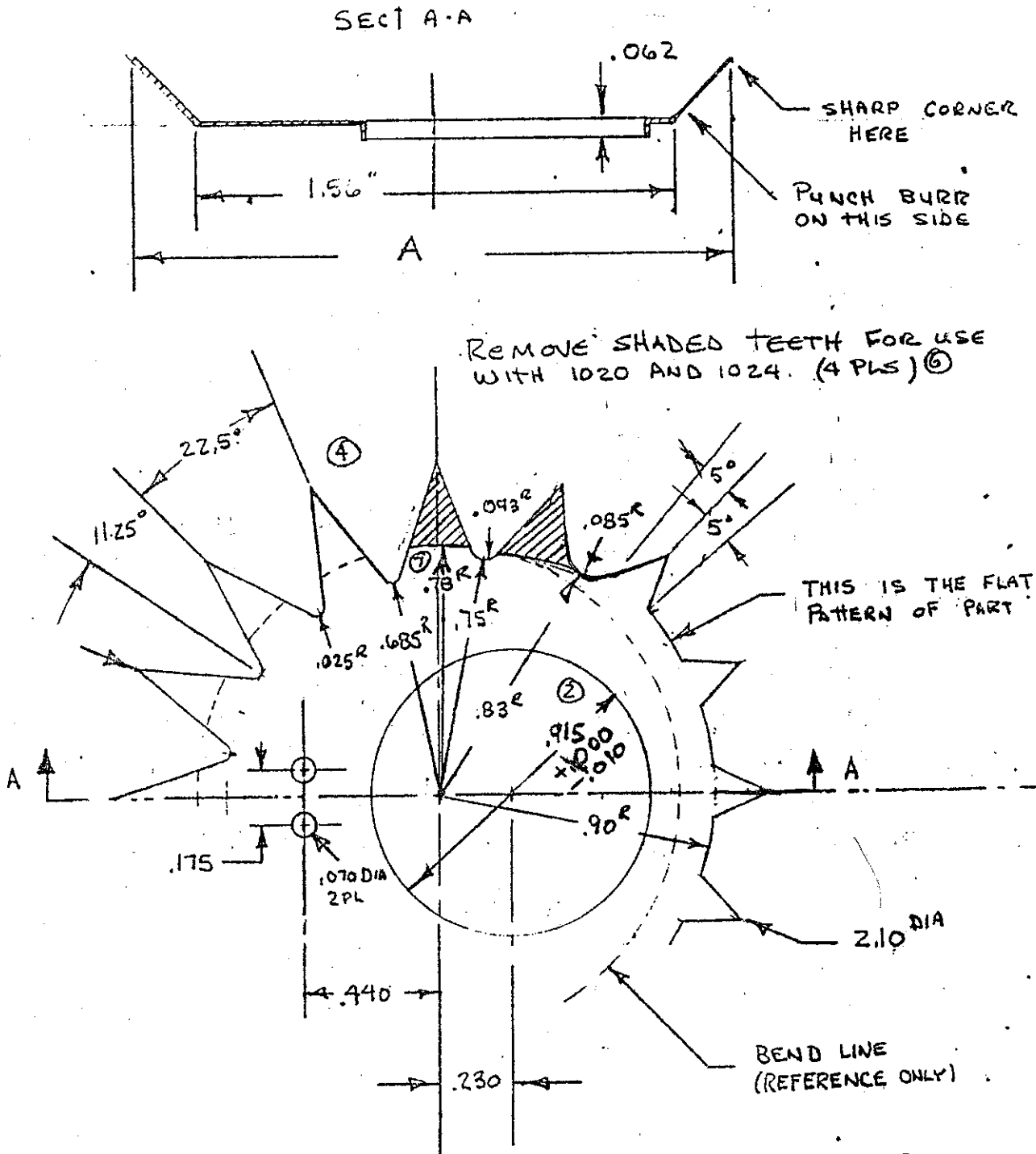

⑤

HEAT TREAT SEE
PRINTS 1020, 1024, 1016, 1017
SPRING TEMPER



ACTUAL ENVELOPE
OF FLAT PATTERN

① MATERIAL THICKNESS
CHANGED FROM .018 to .022-
.028 10-31-85

② TOLERANCE ADDITION
+.000 - .010 10-31-85

③ CHANGE MATL THICKNESS to
.028

④ ADD ALTERNATE PROFILE for
P/N 1020, 1024

⑤ CHANGE HEAT TREAT to
BS SPECIFIC ON 1016, 1020
1024

⑥ ADD 4 PLS 6-3-86
6/12/86

⑦ ADDED .78^R DIM FOR
CHARIFICATION 6/27/86

① ③

MATERIAL 1075 THICKNESS .028 - .030
USED ON 1020, 1024, 1016

sh: BLACK OXIDE AND OIL

TITLE:

TANK SENTRY BLANK
WITH LIP

DR LAK 9/22/85

CK

SCALE.

1" = 1/2"

PART NUMBER

M-DOC 1014-O REUD

ORIGINAL PRINT

USE PART NUMBER M-DOC 1014-0-DPRINT

"A" DIMENSION = 1.95

HEAT TREAT RC46-48 W/ .028 THICK MATERIAL

USED ON

				ISSUE	ISSUE DATE AND CHANGE RECORD	REV.	CHG.							
TOLERANCE AND SURFACE ROUGHNESS UNLESS NOTED				TITLE #150 SENTRY WITH LIP AND FLAPPER FOR G.M. 1/2 AMC "SCREW IN TYPE"										
OPERATION	PLACES IN DIMENSION							MAXIMUM SURFACE ROUGHNESS	PART NO. M-DOC 1024 REV B					
	.0	.00	.000											
MACHINING	±.1	±.02	±.005					✓				A		
DR. (SAW, REAR)	±.1	±.04	////											
	±	±	±											
WELDING	±.1	±.06	DR. LAK	5-15-86										
ANGULAR DIM.	±		CH.											
SCALE			APP.											

APPENDIX A
Continued

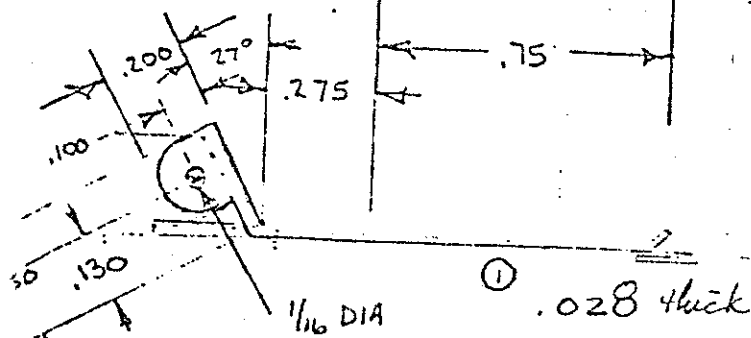
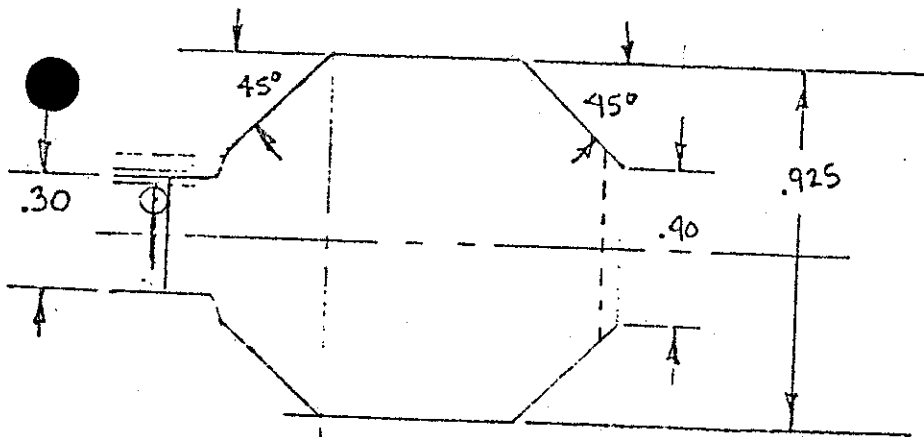

PIU M.DOC 1012-0
FLAP.

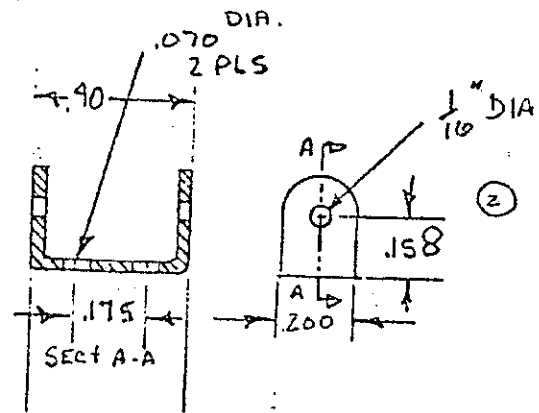

PIU M.DOC 1013-0
U-BRACKET

9. MATERIAL 300 SERIES
STAINLESS STEEL

APPENDIX A
Continued

① CHANGED FROM .020
.028 10-31-8
② CHANGED FROM .150
.158 10-31-

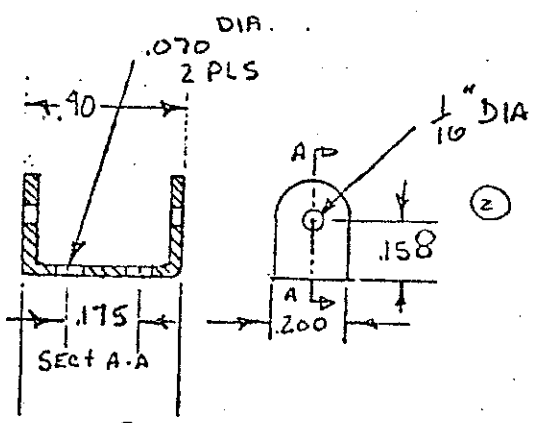
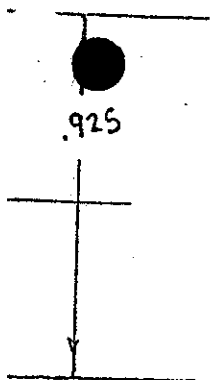

PIV M DOC 1013-0
U-BRACKET

MATERIAL 300 SERIES
STAINLESS STEEL

FLAPPER SPRING ASSY
SCALE = 2X

7/21/85
LAK

Tank Sentry With Flapper Installation/Instruction Sheet

The tank sentry is a convenient, quick and inexpensive way to repair damaged or tampered unleaded gas filler tube restrictors.

The tank sentry can be inserted without removing the gas tank or gas filler tube from the car with a hammer blow to a suitable sized socket or dowel driving restrictor into place.

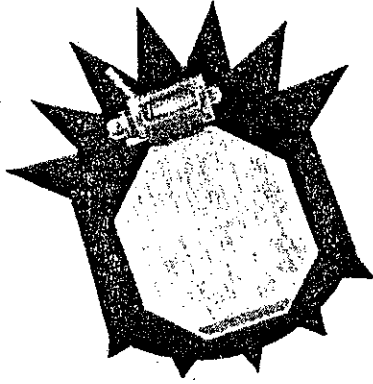

Tank Sentry with Flapper

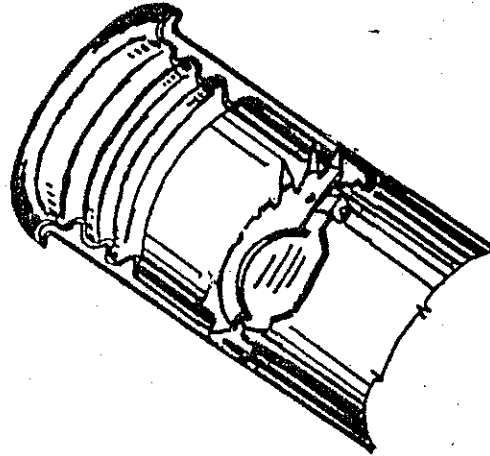

Typical Installation

Position #150 Tank Sentry with 5 teeth at *bottom* of filler pipe (7 at top) for installation. Insert 5 teeth section past the threads at a 45° angle into the neck directly on *top* of the existing lip of original equipment section. The 7 teeth will, at this point, be resting on top of the threads. After proper positioning, drive into place using a suitably sized socket or dowel against the top seven teeth, but below the bend line.

CAUTION: Make sure tampered hole is large enough to accept Tank Sentry with Flapper prior to installation. If the new hole does not align properly use a screwdriver or suitable tool to rotate the Tank Sentry so filler holes do align.

NOTE: The Tank Sentry MUST be in alignment with the former restrictor hole and as close as possible in depth to original restrictor to be in compliance. If the former hole does not exist or is greatly enlarged, the Tank Sentry should always be installed so that the offset filler hole is positioned toward the bottom of the filler pipe.

Limitations

- All makes & models where tampering is so extensive that the Original Equipment Restrictor metal has been completely removed or any filler pipe with an inside diameter of more than 1.950 inches.
- All Ford Motor Co. vehicles. (Use our Part #278 for Ford vehicles with "stepped" double flange on inside of tube.)

This Executive Order does not constitute any opinion as to the effect that the use of this device may have on any warranty either expressed or implied by the vehicle manufacturer.

THIS EXECUTIVE ORDER DOES NOT CONSTITUTE A CERTIFICATION, ACCREDITATION, APPROVAL, OR ANY OTHER TYPE OF ENDORSEMENT BY THE AIR RESOURCES BOARD OF ANY CLAIMS OF THE APPLICANT CONCERNING ANTI-POLLUTION BENEFITS OR ANY ALLEGED BENEFITS OF THE POLLUTION CONTROL AUTO PARTS' TANK SENTRY DEVICE.

No claim of any kind, such as "Approved by Air Resources Board" may be made with respect to the action taken herein in any advertising or other oral or written communication.

Section 17500 of the Business and Professions Code makes untrue or misleading advertising unlawful, and Section 17534 makes violation punishable as a misdemeanor.

Section 43644 of the Health and Safety Code provides as follows:

"43644. (a) No person shall install, sell, offer for sale, or advertise, or, except in an application to the state board for certification of a device, represent, any device as a motor vehicle pollution control device for use on any used motor vehicle unless that device has been certified by the state board. No person shall sell, offer for sale, advertise, or represent any motor vehicle pollution control device as a certified device which, in fact, is not a certified device. Any violation of this subdivision is a misdemeanor."

Any apparent violation of the conditions of this Executive Order will be submitted to the Attorney General of California for such action as he deems advisable.

Executed at El Monte, California, this 9th day of June, 1987.

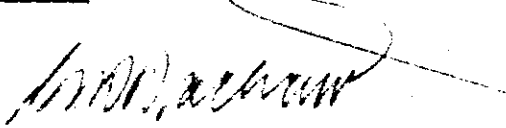
K. D. Drachand, Chief
Mobile Source Division

STATE OF CALIFORNIA
AIR RESOURCES BOARD

EVALUATION OF POLLUTION CONTROL AUTO PARTS' MODEL #225 TANK SENTRY DEVICE FOR
EXEMPTION FROM THE PROHIBITIONS OF VEHICLE CODE SECTION 27156 IN ACCORDANCE
WITH SECTION 2222, TITLE 13, OF THE CALIFORNIA ADMINISTRATIVE CODE

June, 1987

June, 1987

State of California
AIR RESOURCES BOARD

Evaluation of Pollution Control Auto Parts' Model #225 Tank Sentry Device for
Exemption from the Prohibitions of Vehicle Code Section 27156 in Accordance
with Section 2222, Title 13, of the California Administrative Code

by

Mobile Source Division
State of California
Air Resources Board
9528 Telstar Avenue
El Monte, CA 91731

(This report has been reviewed by the staff of the California Air Resources Board and approved for publication. Approval does not signify that the contents necessarily reflect the views and policies of the Air Resources Board, nor does mention of trade names or commercial products constitute endorsement or recommendation for use.)

SUMMARY

Pollution Control Auto Parts of 10470 Grey Cloud Trail South, Cottage Grove, Minnesota 55016, has applied for an exemption from the prohibitions of California Vehicle Code (V.C.) Section 27156 for its model #225 Tank Sentry device, which is to be used for replacing damaged or tampered unleaded fuel filler pipe restrictors on catalyst equipped Ford Motor Company vehicles that do not have "stepped" in diameter or double flange filler pipes, on catalyst equipped Chrysler Corporation vehicles with "funnel" shaped gas filler pipes, and on specified catalyst equipped AMC and Mazda vehicles. The Tank Sentry device is only applicable for replacing original equipment manufacturer (OEM) device where remains of the OEM restrictor exist, and it is designed to be used on vehicles with filler pipes which have an inside diameter between 2.10 to 2.25 inches only. V.C. Section 27156 prohibits modifications to emission controlled vehicles which cause a reduction in the effectiveness of the vehicle's emission control systems.

The applicant submitted samples of the device and filler pipes for examination and evaluation. The staff evaluated the device in accordance with the ARB's Specifications for Fuel Fill Pipes and Openings of Motor Vehicle Fuel Tanks. The staff also performed installation experiments and bench tests to determine the durability of the device. Based on the obtained results, the staff concludes that the model #225 Tank Sentry device meets the exemption requirements for installation on specified Chrysler, Ford, AMC and Mazda vehicles.

The staff recommends that the Pollution Control Auto Parts be granted an exemption from the prohibitions of California Vehicle Code Section 27156 for their model #225 Tank Sentry device and that Executive Order D-154-4 be issued.

TABLE OF CONTENTS

	<u>Page No.</u>
SUMMARY	i
TABLE OF CONTENTS	ii
I. INTRODUCTION	1
II. CONCLUSION	1
III. RECOMMENDATION	1
IV. DEVICE DESCRIPTION	2
V. DEVICE EVALUATION	3
VI. DISCUSSION	4
VII. APPENDICES	6
APPENDIX A Drawings and Specifications of Model #225 of the Tank Sentry Device	6
APPENDIX B Installation Instructions	7
APPENDIX C Catalog Sheet	8

EVALUATION OF POLLUTION CONTROL AUTO PARTS' TANK SENTRY DEVICE MODEL #225 FOR EXEMPTION FROM THE PROHIBITIONS OF VEHICLE CODE SECTION 27156 IN ACCORDANCE WITH SECTION 2222, TITLE 13, OF THE CALIFORNIA ADMINISTRATIVE CODE

I. INTRODUCTION

Pollution Control Auto Parts of 10470 Grey Cloud Trail South, Cottage Grove, Minnesota 55016, has applied for exemption from the prohibitions of California Vehicle Code Section 27156 for its model #225 Tank Sentry device. This device is designed to replace damaged or tampered OEM unleaded fuel filler pipe restrictors on catalyst equipped Chrysler Corporation vehicles with "funnel" shaped gas filler pipes, on catalyst equipped Ford Motor Company vehicles that do not have "stepped" in diameter or double flange filler pipes, and on specified catalyst equipped AMC and Mazda vehicles. The Tank Sentry device is only applicable for replacing OEM device where remains of the OEM restrictor exist and it is designed to be used on vehicles with filler pipes which have an inside diameter between 2.10 to 2.25 inches only. Vehicle Code Section 27156 prohibits modifications to required vehicle emission control systems. Exemptions to the Section are granted upon demonstration that the device does not increase emissions or reduce the effectiveness of the required emission control systems of applicable vehicles.

II. CONCLUSION

Based on the detailed studies of the design, installation experiments and bench tests to determine durability of the device, the staff concludes that the model #225 Tank Sentry device meets the Vehicle Code Section 27156 requirements for exemption, for installation on specified Chrysler, Ford, AMC and Mazda vehicles.

III. RECOMMENDATION

The staff recommends that Pollution Control Auto Parts be granted an exemption from the prohibitions of California Vehicle Code Section 27156 for

their model #225 Tank Sentry device, for installation on specified Chrysler, Ford, AMC and Mazda vehicles and that Executive Order D-154-4 be issued.

IV. DEVICE DESCRIPTION

The Pollution Control Auto Parts' model #225 Tank Sentry device is an unleaded fuel filler pipe restrictor designed to replace damaged or tampered OEM restrictors. The model #225 restrictor fits into specified fuel filler pipes on Chrysler, AMC, Ford and Mazda vehicles. It is not applicable for replacing OEM restrictors which have been completely removed; without any support, the device would fall through the filler pipe into the tank. This device is designed to be used on vehicles with filler pipes which have an inside diameter between 2.10 to 2.25 inches only.

The device is made of 0.028 inch sheet metal (see Appendix A for drawings and specifications of the device). The device has a 0.915 inch diameter filling hole for passing the nozzle to the required depth in the filler pipe. This filling hole has an eccentricity of 0.230 inch with respect to the centerline of the filler pipe neck. The overall diameter of the device is 2.210 inches. The diameter of the device where the teeth have been removed is 1.56 inches. Attached to the hind side of the device is a spring loaded 0.028 inch thick flapper door which covers the filling hole and is maintained in the closed position. Executive Order No. D-154-4 and the company's name "PCAP" will be imprinted on the front side of the flapper door.

The device has twelve (12) sharp teeth, seven of which are longer and less spaced and located on the far side of the inner hole (near the spring) and five of which are located on the near side of inner hole. The teeth allow the device to be pushed into the filler pipe and to sit on top of the remains of the OEM restrictor.

According to the installation instructions (see Appendix B), the device can be installed without removing the gas tank or gas filler tube from the vehicle. Once installed, it can not be removed since the teeth are all bent upward, and the device is squeezed tightly against the filler pipe wall.

V. DEVICE EVALUATION

The device was evaluated for its: 1) ability to restrict leaded fuel nozzles, 2) compliance with the Specifications for Fill Pipe and Openings of Motor Vehicle Fuel Tanks, and 3) durability.

The filling hole diameter of the device is 0.915 inches for passing the unleaded fuel nozzle but restricting the insertion of a leaded fuel nozzle. There are openings between the teeth around the circumference of the device when installed. The openings are not large enough to allow misfueling.

According to the ARB's Specification for Fill Pipes and Openings of Motor Vehicle Fuel Tanks, "angle alpha" is the angle between the axial centerline of the filler pipe face and the axial centerline of the test nozzle spout when in its normal resting position. This angle should fall within the range of - 10° and 20°, and the penetration of the test fuel nozzle in the filler pipe should be at least 2.25 centimeters. After a review of the company's installation instructions, the staff is of the opinion that model #225 Tank Sentry device when installed properly will meet the above requirements. The Tank Sentry device is only applicable for replacing OEM device where remains of the OEM restrictor exist.

The submitted samples of the device were installed in the following filler pipes:

1. Chrysler's filler pipe which has an inside diameter of 2.10 inches

2. Ford Motor Company's filler pipe without a "stepped" in diameter and which has a diameter of 2.25 inches
3. AMC's filler pipe which has an inside diameter of 2.10 inches
4. Mazda's filler pipe which has an inside diameter of 2.20 inches

The filler pipes were clamped in a vice and tested for durability. The durability test consisted of inserting and removing an unleaded fuel nozzle through the device 250 times. This is approximately equal to the number of times an individual would fill a vehicle's gas tank in five (5) years. The restrictor remained in its place during the entire test of simulated filling operation.

Based on the above, the staff concludes that if the device is installed correctly it will function the same as an OEM restrictor, and it meets the requirements for exemption from the prohibitions of California Vehicle Code Section 27156.

VI. DISCUSSION

Pollution Control Auto Parts of Minnesota has applied for exemption from the prohibitions of California Vehicle Code Section 27156 for the model #225 Tank Sentry device for use on specified Chrysler, Ford, AMC and Mazda vehicles. The model #225 Tank Sentry device is similar to the model #150 Tank Sentry device which has been exempted by ARB. The difference between the two devices is that the teeth of model #225 are larger than the teeth of model #150; the outside diameter of the model #150 device is 1.95 inches versus the 2.210 inches diameter of model #225. Therefore, the model #225 device can be installed on larger diameter filler pipe. The model #225 Tank Sentry device was found to fit on specified Chrysler, Ford, AMC and Mazda vehicles. However, this device is not applicable for replacing OEM restrictors which have been completely removed; without any support, the device would fall

through the filler pipe into the tank. Also, this device is designed to be used on vehicles with filler pipes which have an inside diameter of 2.10 to 2.25 inches only.

The staff is of the opinion that the model #225 Tank Sentry device meets the requirements for exemption from the prohibitions of Vehicle Code Section 27156 for the installation on specified Chrysler, Ford, AMC and Mazda vehicles. The staff recommends that Executive Order D-154-4 be issued.

Appendix A

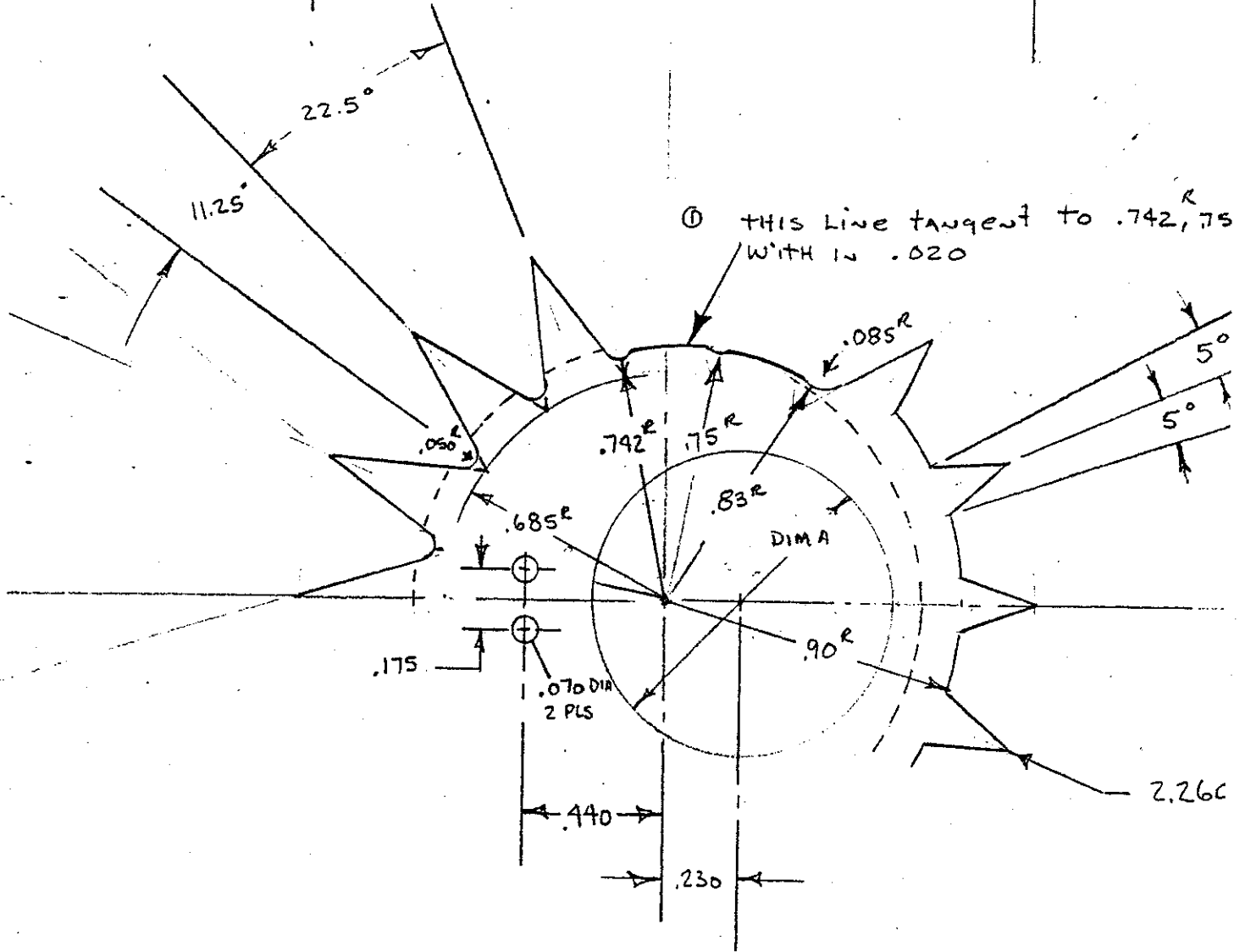
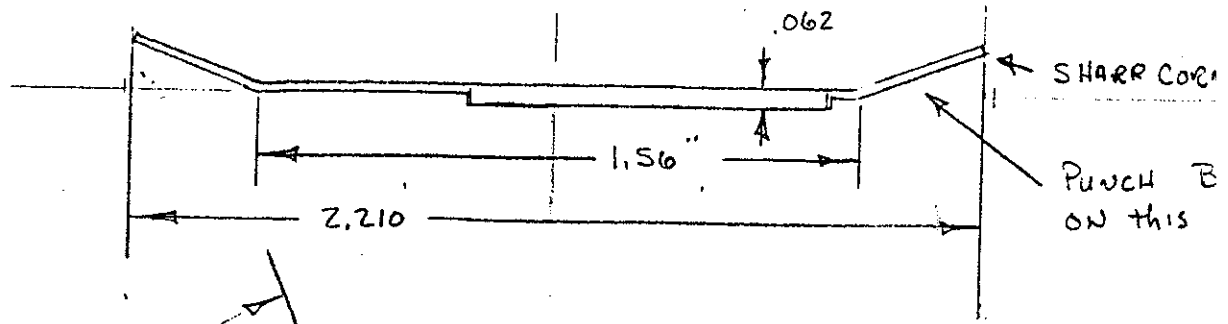

MA
HE
OH
FI

These kits cover the majority of the applicable vehicles in the states as listed in the company's Application Data booklet. The tests were performed by Lumenition Limited, at their test facility, as required per Air Resources Board "Criteria for Aftermarket Ignition System Modifications" procedures.

VI. RESULTS

Lumenition Limited's test data are shown in the Appendices. The submitted test data show that:

- A. The secondary available voltage of the device test is within ten (10) percent of the baseline available secondary voltage;
- B. The rise time with the device is more than ten (10) microseconds;
- C. The spark duration with the device is more than 100 microseconds;
and
- D. The spark energy with the device is not degraded by more than 20% from the baseline spark energy.

In summary, they meet the Air Resources Board's evaluation criteria for aftermarket ignition systems.

VII. DISCUSSION

Based on the applicant's bench test data, the staff concludes that the "Lumenition" ignition system complies with the requirements for the exemption from the prohibitions in V.C. Section 27156.

① NOTE added 5/25/87

HERE

RECEIVED
MAY 26 1987
AFTERMARKET PARTS SECTION
NEW VEHICLE PROGRAMS BRANCH
MOBILE SOURCE DIVISION

CR
DE

.830^e

DIM A .915 +.000 FINISHED
 -.015 HOLE SIZE
 .820 BEFORE FORMING

1075 thickness .018-.028
BEAT TO RC-44-48
OR HEAT TREAT
BLACK OXIDE AND OIL
DUAL 2" = 1"

DR KAK 2/28/87	TITLE 2.260 BLANK SIZE TANK SENTRY 2.210 OVERALL
PART NUMBER M.DOC 1018	

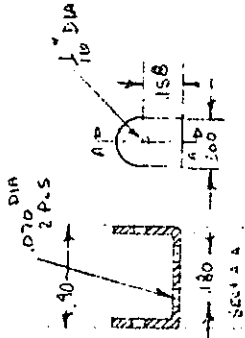
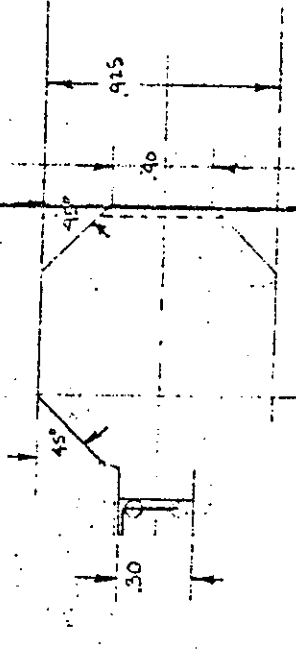

PIV M.DOC 1013-0
U-BRACKET

MATERIAL 300 SERIES
STAINLESS STEEL

0.30 THICK

FLAPPER SPRING ASSY
SCALE 2X

7/2/85
ZAK

ALDOC-1011

PIV M.DOC 1012-0
FLAP

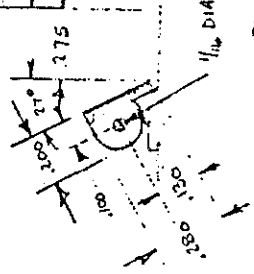

#225 Tank Sentry With Flapper Installation/Instruction Sheet

The tank sentry is a convenient, quick and inexpensive way to repair damaged or tampered unleaded gas filler tube restrictors.

The tank sentry can be inserted without removing the gas tank or gas filler tube from the car with a hammer blow to a suitable socket or dowel driving restrictor into place.

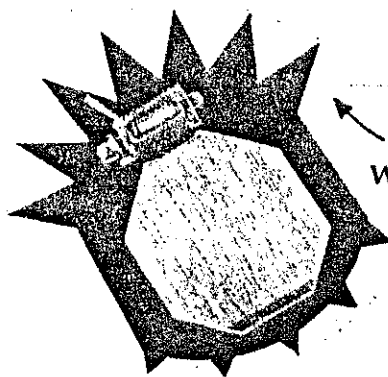

#225 TANK SENTRY WITH FLAPPER

SNAP OFF THIS TOOTH.
WITH PLIERS AS REQUIRED

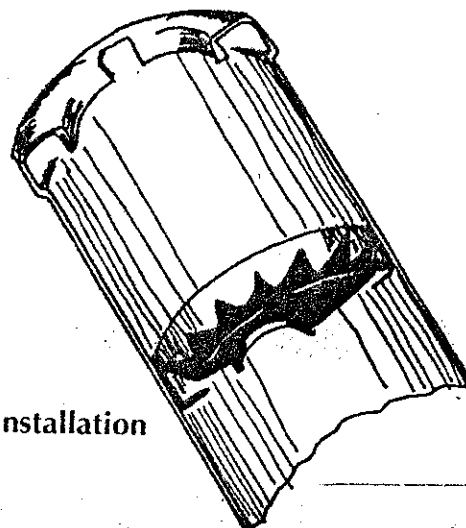

Typical Installation

1

Position the #225 Tank Sentry with 5 teeth toward bottom of filler pipe (6 to 7 teeth at top) for installation. If Tank Sentry will not slip past the two notches in the lip of the neck, snap off 7th tooth for easy insertion (see illustration above).

Step 2

Insert the tank sentry at a 45 degree angle into the neck with the top 6-7 teeth still outside the lip and the 5 teeth inside the lip but above old restrictor cross section. Push the 6-7 teeth top section past the lip by hand with a suitably sized socket or dowel. After proper positioning, drive into place using the socket or dowel.

CAUTION: Make sure tampered hole is large enough to accept Tank Sentry with Flapper prior to installation. If the new hole does not align properly, use a screwdriver or suitable tool to rotate the Tank Sentry so filler holes do align.

NOTE: The Tank Sentry **MUST** be in alignment with the former restrictor hole and as close as possible in depth to original restrictor to be in compliance. If the former hole does not exist or is greatly enlarged, the Tank Sentry should always be installed so that the offset filler hole is positioned toward the bottom of the filler pipe.

Limitations:

THE #225 TANK SENTRY FITS VEHICLES WITH THE FOLLOWING EXCEPTIONS:

ALL MAKES & MODELS WHERE TAMPERING IS SO EXTENSIVE THAT THE O.E. RESTRICTOR METAL HAS BEEN COMPLETELY REMOVED.

ALL FOREIGN OR DOMESTIC VEHICLES HAVING FILLER NECKS WITH AN INSIDE DIAMETER OF LESS THAN 2.10 INCHES, OR MORE THAN 2.25 INCHES.



POLLUTION CONTROL AUTO PARTS

10470 GREY CLOUD TRAIL SOUTH COTTAGE GROVE, MINNESOTA 55016
(612) 459-9213

TOLL FREE 1-800-525-0016 EXT. 687314

WAREHOUSE DISTRIBUTOR PRICE EFFECTIVE APRIL 30, 1987

<u>PART NUMBERS</u>	<u>DESCRIPTION</u>	<u>LIST PRICE</u>	<u>DEALER COST</u>	<u>JOBBER COST</u>	<u>W/D COST</u>
150, 278 and 225	TANK SENTRY WITH FLAPPER	\$14.25	\$11.40	\$8.55	\$6.00

TERMS OF PAYMENT:

4% 10 DAYS RECEIPT OF GOODS - NET: 10th PROX

FREIGHT:

COLLECT

PACKAGING:

INDIVIDUALLY PACKAGED

RETURNS:

WRITTEN AUTHORIZATION REQUIRED

W/D QUALIFICATIONS:

100 @ \$6.00 or \$600.00

PRICES:

SUBJECT TO CHANGE WITHOUT NOTICE

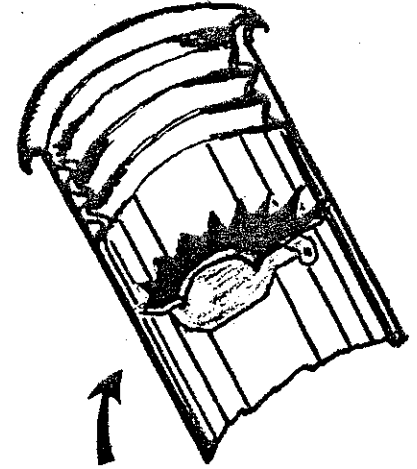

Typical Installation of
#150 Tank Sentry

Pat. No.
4,635,813

APPLICATION:

TANK SENTRY APPLICATION - FITS	With Flapper PART NO.
All General Motor, Ford, AMC, Chrysler Corp vehicles with "screw in" type fuel filler caps, plus Chrysler Corp "twist on" type.	#150
Ford Motor Co. vehicles with "stepped" double flange on inside of tube.	#278
• Chrysler Corp. vehicles with "funnel" shaped gas filler necks which have an inside diameter exceeding 2.095 inches. • Ford Motor Co. vehicle gas filler necks without stepped diameter or double flange. AMC 76-80 Jeep, CJ5 & 7, Cherokee & Wagoneer. 79-83 Mazda B-200 & 77-81 Courier	#225

Limitations to Tank Sentry with Flapper:

- All makes & models where tampering is so extensive that the O.E. Restrictor metal has been completely removed.
- Device will not "seat" properly outside of diameter range listed on chart below:

Part No's	Inches
150/200	1.950
278/216	2.090
225/221	2.250

* See page 2 for Ford/Chrysler application.

NOTES
1) SWITCH SPECIFICATIONS:

- SWITCH #1 - BLUE
CLOSE AT 2.5 ± 1.3 Cm H_g GAUGE PRESSURE
OPEN AT NOT LESS THAN 90% OF CLOSING PRESSURE.
- SWITCH #2 - PINK
CLOSE AT 9.0 ± 1.3 Cm H_g GAUGE PRESSURE
OPEN AT NOT LESS THAN 90% OF CLOSING PRESSURE.
- SWITCH #3 - BLACK
OPEN AT 41.5 ± 1.3 Cm H_g GAUGE PRESSURE
CLOSE AT NOT LESS THAN 90% OF OPENING PRESSURE.

2) ALL WIRE TO BE 18 GAUGE, -SAE TYPE GPT

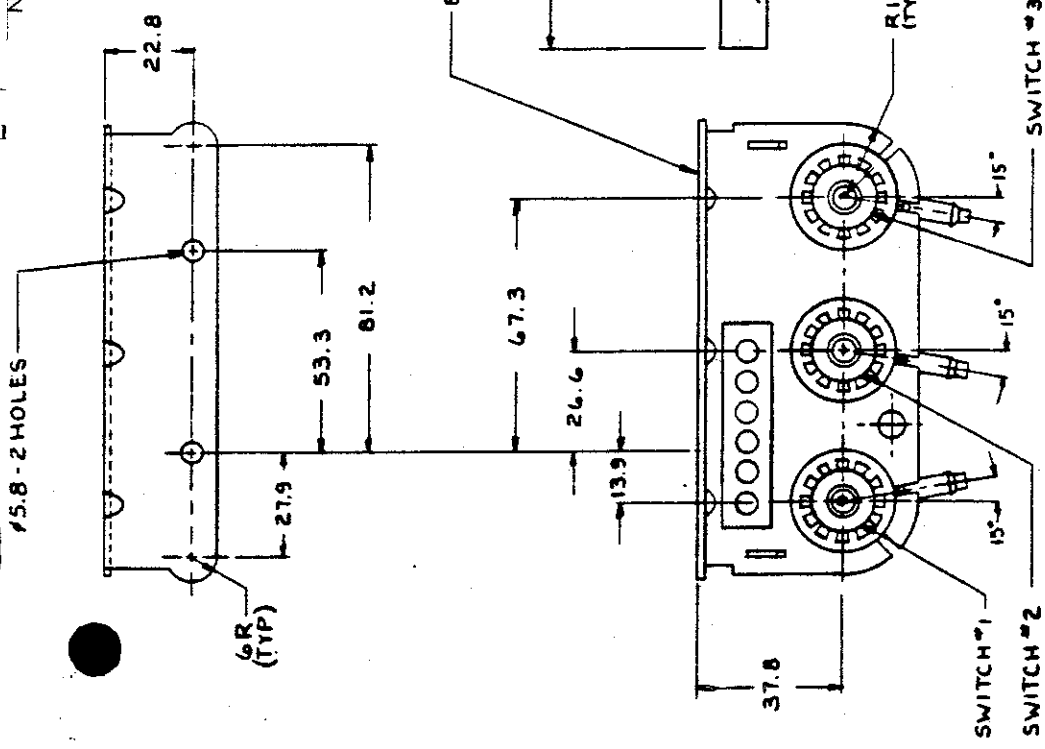

SWITCH NO.	PIN NO.	CIRCUIT NO.	WIRE COLOR
1	1	1A	BR/W
	2	2	BR
2	4	2A	BR/BL
	5	3	BR
3	6	4	BK
			BK/W

APPENDIX A-6

REL FOR PROD	3-8-82	DATE	
REVISION RECORD		DATE	
REL. PRODUCT		DATE	

MCD ASSOCIATES, INC.

THIRD ANGLE PROJECTION

PART TOLERANCE UNLESS OTHERWISE SPECIFIED ANGULAR

± 0.25 ± 1'0"

NUMBER OF DECIMAL PLACES DOES NOT IMPLY A TOLERANCE

DO NOT SCALE PRINT

DESIGNED BY: [Signature]

DATE: 2-8-82

SCALE: FULL

CHECKED: [Signature]

MATERIAL:

SEE NOTES

PART NAME: SWITCH ASSY - PRESSURE

PART NO: C410810131

NEXT ASSY: 41080000

METRIC
INSPECT TO METRIC SPECIFICATIONS