

State of California  
AIR RESOURCES BOARD

EXECUTIVE ORDER D-161-29  
Relating to Exemptions Under Section 27156  
of the Vehicle Code

GALE BANKS ENGINEERING  
WASTEGATE TURBO UPGRADE

Pursuant to the authority vested in the Air Resources Board by Section 27156 of the Vehicle Code; and

Pursuant to the authority vested in the undersigned by Section 39515 and 39516 of the Health and Safety Code and Executive Order G-45-5;

IT IS ORDERED AND RESOLVED: That the installation of the Wastegate Turbo Upgrade, manufactured by Gale Banks Engineering of 546 Duggan Avenue, Azusa, CA 91702, has been found not to reduce the effectiveness of required motor vehicle pollution control devices, and therefore is exempt from the prohibitions of Section 27156 of the Vehicle Code for the following Cummins heavy-duty diesel applications:

<u>MODEL YEAR</u>	<u>ENGINE FAMILY</u>	<u>MAXIMUM BOOST</u>
1989-1991	6BT 5.9L	20 p.s.i.g.
1991-1992	6BTA 5.9L	17 p.s.i.g.
late 1992-1993	6BTA 5.9L	20 p.s.i.g.

This exemption shall not apply to any device, apparatus, or mechanism advertised, offered for sale or sold with, or installed on, a motor vehicle prior to or concurrent with transfer to an ultimate purchaser.

This Executive Order is valid provided that installation instructions for this device will not recommend tuning the vehicle to specifications different from those submitted by the device manufacturer.

Changes made to the design or operating conditions of the device, as exempted by the Air Resources Board, that adversely affect the performance of a vehicle's pollution control system shall invalidate this Executive Order.

Marketing of this device using an identification other than that shown in this Executive Order or marketing of this device for an application other than those listed in this Executive Order shall be prohibited unless prior approval is obtained from the Air Resources Board. Exemption of a kit shall not be construed as an exemption to sell, offer for sale, or advertise any component of the product as an individual device.

This Executive Order does not constitute any opinion as to the effect that the use of this device may have on any warranty either expressed or implied by the vehicle manufacturer.

**THIS EXECUTIVE ORDER DOES NOT CONSTITUTE A CERTIFICATION, ACCREDITATION, APPROVAL, OR ANY OTHER TYPE OF ENDORSEMENT BY THE AIR RESOURCES BOARD OF ANY CLAIMS OF THE APPLICANT CONCERNING ANTI-POLLUTION BENEFITS OR ANY ALLEGED BENEFITS OF THE WASTEGATE TURBO UPGRADE.**

No claim of any kind, such as "Approved by the Air Resources Board" may be made with respect to the action taken herein in any advertising or other oral or written communications.

Section 17500 of the Business and Professions Code makes untrue or misleading advertising unlawful, and Section 17534 makes violation punishable as a misdemeanor.

Section 43644 of the Health and Safety Code provides as follows:

"43644, (a) No person shall install, sell offer for sale, or advertise or except in an application to the state board for certification of a device, represent, any device as a motor vehicle pollution control device for use on any used motor vehicle unless that device has been certified by the state board. No person shall sell, offer for sale, advertise, or represent any motor vehicle pollution control device as a certified device which, in fact, is not a certified device. Any violation of this subdivision is a misdemeanor."

Any apparent violation of the conditions of this Executive Order will be submitted to the Attorney General of California for such action as he deems advisable.

Executed at El Monte, California, this 26<sup>th</sup> day of October, 1992.

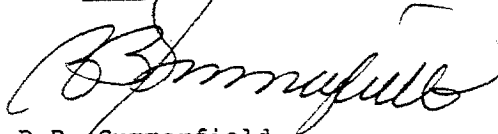

R.B. Summerfield  
Assistant Division Chief  
Mobile Source Division

State of California  
AIR RESOURCES BOARD

EVALUATION OF GALE BANKS ENGINEERING'S  
WASTEGATE TURBO UPGRADE FOR EXEMPTION FROM THE PROHIBITIONS OF  
VEHICLE CODE SECTION 27156 IN ACCORDANCE WITH SECTION 2222, TITLE 13, OF THE  
CALIFORNIA CODE OF REGULATIONS

October 1992

State of California  
AIR RESOURCES BOARD

EVALUATION OF GALE BANKS ENGINEERING'S  
WASTEGATE TURBO UPGRADE FOR EXEMPTION FROM THE PROHIBITIONS OF  
VEHICLE CODE SECTION 27156 IN ACCORDANCE WITH SECTION 2222, TITLE 13, OF THE  
CALIFORNIA CODE OF REGULATIONS

by

Mobile Source Division  
State of California  
Air Resources Board  
9528 Telstar Avenue  
El Monte, CA 91731-2990

(This report has been reviewed by the staff of the California Air Resources Board and approved for publication. Approval does not signify that the contents necessarily reflect the views and policies of the Air Resources Board, nor does mention of trade names or commercial products constitute endorsement or recommendation for use.)

SUMMARY

Gale Banks Engineering (Banks) of 546 Duggan Avenue, Azusa, California 91702, has applied for an exemption from the prohibitions in Section 27156 of the California Vehicle Code (VC) for the Wastegate Turbo Upgrade. The Wastegate Turbo Upgrade is designed for installation on 1989-1992 Dodge Cummins 6BT and 6BTA heavy-duty diesel engines.

Banks submitted a completed application and other required information, as well as results from snap-idle tests performed at the Gale Banks facility in Azusa, in accordance with Section 2182, Title 13, California Code of Regulations.

Based on the submitted information and an engineering evaluation, the staff concludes that the Banks turbo upgrade will not adversely affect exhaust emissions from vehicles for which an exemption is requested.

The staff recommends that Gale Banks Engineering, be granted an exemption as requested and that Executive Order D-161-29 be issued.

TABLE OF CONTENTS

	Page Number
SUMMARY	i
CONTENTS	ii
I. INTRODUCTION	1
II. CONCLUSION	1
III. RECOMMENDATION	1
IV. WASTEGATE TURBO UPGRADE DESCRIPTION	2
V. DISCUSSION	2
APPENDIX A: INSTALLATION INSTRUCTIONS	5

EVALUATION OF GALE BANKS ENGINEERING'S  
WASTEGATE TURBO UPGRADE FOR EXEMPTION FROM THE PROHIBITIONS OF  
VEHICLE CODE SECTION 27156 IN ACCORDANCE WITH SECTION 2222, TITLE 13, OF THE  
CALIFORNIA CODE OF REGULATIONS

I. INTRODUCTION

Gale Banks Engineering (Banks) of 546 Duggan Avenue, Azusa, California 91702, has applied for an exemption from the prohibitions in Section 27156 of the California Vehicle Code (VC) for their Wastegate Turbo Upgrade. The turbo upgrade is designed for installation on 1989-92 Cummins 6BT and 6BTA heavy-duty diesel engines.

Banks submitted a completed application and other required information, as well as results from snap-idle tests performed at the Gale Banks facility in Azusa, in accordance with Section 2182, Title 13, California Code of Regulations.

II. CONCLUSIONS

Based on the submitted information and an engineering evaluation, the staff concludes that the Banks turbo upgrade will not adversely effect exhaust emissions from vehicles for which an exemption is requested.

III. RECOMMENDATION

The staff recommends that Gale Banks Engineering, be granted an exemption for their Wastegate Turbo Upgrade for installation on 1989-1992 Dodge Cummins 6BT and 6BTA heavy-duty diesel engines. The staff also recommends that Executive Order D-161-29 be issued.

#### IV. WASTEGATE TURBO UPGRADE DESCRIPTION

Banks's Wastegate Turbo Upgrade consists of a replacement turbine housing and a wastegate valve. The purpose of the turbo upgrade is to decrease turbo lag by speeding up the air through the turbocharger, increasing the acceleration of the turbine blades. The velocity of the air is increased by reducing the area of the exhaust passage to the turbocharger. By increasing the velocity of the air entering the turbocharger, the turbine is accelerated more quickly, reducing the lag between engine acceleration and turbo boost. The boost pressure is maintained at the factory level by adding a wastegate valve, which bypasses some exhaust air when the pressure exceeds the limit.

The Wastegate Turbo Upgrade is designed to maintain the factory boost level. For this reason, two different wastegate actuators will be produced. The first actuator is for 1989-1991 Cummins 6BT and late 1992-1993 Cummins 6BTA engines with a factory boost pressure of 20 p.s.i.g. The second wastegate actuator is for late 1991 to late 1992 Cummins 6BTA engines with 17 p.s.i.g. boost pressure.

#### V. DISCUSSION

Gale Banks Engineering has requested that the Wastegate Turbo Upgrade be exempted for the 1989-1992 Cummins 6BT and 6BTA heavy duty diesel engines. The Wastegate Turbo Upgrade is designed to reduce the lag time between engine acceleration and turbo boost. During the lag time between engine acceleration and turbo boost, the engine is running rich resulting in unburned fuel due to a shortage of oxygen. The reduction of turbo lag time could decrease Hydrocarbon and particulate emissions by reducing the duration of the oxygen shortage. The difference in turbo lag time between the original equipment (OEM) turbocharger



and the modified turbocharger is three seconds or less. All other operating conditions of the turbocharger remain the same. Because the modification occurs only during initial acceleration, and the reduction in turbo lag is minimal, the combustion temperature is not affected. For this reason, the staff has determined that the Oxides of Nitrogen emissions will not be increased.

Banks provided snap-idle test results for a 1992 Cummins 6BTA 5.9 liter engine with the Wastegate Turbo Upgrade installed. The results of the snap-idle test performed at Banks are shown in Table 1.

Table 1

SNAP-IDLE TEST RESULTS  
(Gale Banks Engineering)

	<u>MAX OPACITY</u>
Standard	40%
Modified	34%
difference	-6%

These results show that the modified vehicle emissions do not exceed the 40% opacity standard.

Banks submitted all of the required information and fulfilled the requirements for an exemption. The test results and engineering analysis show that the Banks Wastegate Turbo Upgrade meets the requirements for exemption.



Gale Banks Engineering 546 Duggan Avenue Azusa, California 91702 (818) 969-9605

FAX (818) 334 8078

GALE BANKS ENGINEERING  
DODGE/CUMMINS DIESEL PICKUP  
WASTEGATE TURBO UPGRADE

The Banks Wastegate Turbo Upgrade package is designed to greatly improve the response of the Dodge/Cummins 5.9BT 6-cylinder diesel pickup. The addition of a wastegate controlled turbine housing on the existing factory turbocharger allows the engine to achieve its rated power level in a much shorter time interval. The wastegate turbo upgrade is not intended to increase the maximum power level, only to allow the engine to reach it in a much quicker manner. This equates to a far more drivable vehicle and maximized use of the engine's full potential while retaining existing engine durability.

The Banks Wastegate Turbo Upgrade will work well with either the factory or Banks intercooling, and the Banks PowerPack® exhaust systems. Please refer to page 2 for installation tips if other Banks products are being installed with the Wastegate Turbo Upgrade.

If you have any questions or need assistance in installing your Wastegate Turbo Upgrade, please call our Service Department between 8:00am. - 5:00pm. PT at (818) 969-9605. Thank you.

P.N. 96382

GALE BANKS ENGINEERING  
DODGE/CUMMINS DIESEL PICKUP  
WASTEGATE TURBO UPGRADE

GENERAL INSTALLATION PRACTICES

1. For ease of installation and trouble-free operation of your BANKS turbocharger system, PLEASE READ THIS ENTIRE INSTRUCTION PACKAGE BEFORE STARTING ANY WORK. (This package contains 9 pages of instructions, 5 sheets of illustrations, and 1 sheet of parts listing. If any pages are missing from this package, please call GALE BANKS ENGINEERING immediately for a replacement.) Become thoroughly familiar with all components and phases of the installation before starting any work.

2. Inspect all components supplied for any foreign material that may have entered during shipping and handling. Inspect all castings for damage resulting from shipping. Check all machined surfaces for nicks or other damage.

3. Any time the vehicle is raised off its wheels, it should be supported by jack stands, ramps, or a hoist of adequate capacity for the vehicle's weight. NEVER PERFORM ANY WORK UNDER A VEHICLE SUPPORTED ONLY BY ITS SERVICE JACK OR A HYDRAULIC JACK.

4. Pay particular attention to the routing of all hoses and wiring. Keep them away from exhaust heat, moving parts and sharp edges that may cause cuts or other damage. Route or tie hoses away from critical areas as required.

5. Right-hand and left-hand designations refer to the driver's right or left, as seated in the vehicle, (i.e.: Right-hand refers to the passenger side of the vehicle, unless noted otherwise.

6. All BANKS components are designed, tested and manufactured to standards far exceeding factory OEM specifications. However due to normal variations in production vehicles, it may be necessary to slightly modify some exhaust components for proper fit.

7. The turbo boost level calibration is pre-set at our factory. Any increase of the boost level calibration may cause engine damage, and evidence of tampering will be grounds for warranty denial.

8. Torque values for fasteners are given in instruction steps. If torque wrenches are available, use them where applicable, however some fasteners may be in places inaccessible for torquing. In these instances and when no torque wrenches are available, reasonable tightening for the fastener size should be employed.

NOTE: Torque values are given in metric values (Newton-meters), foot-pounds, and inch-pounds.

#### INSTALLATION PROCEDURE

#### WHEN COMBINED WITH OTHER

#### BANKS PRODUCTS

When the Banks Wastegate Turbo Upgrade package is to be installed simultaneously with other Banks power products, the following suggestions will assist in a savings of time and effort during the overall installation.

1. If a Banks Intercooler is being installed on a non intercooled truck, complete the intercooler installation first. This will provide a reference for lining up the turbo ducting when the turbo upgrade is installed.

2. If the factory intercooler is being replaced with a Banks Intercooler, complete the intercooler installation first.

3. If a Banks PowerPack exhaust system is being installed, complete the wastegate turbo upgrade installation before installing the exhaust system.

DODGE/CUMMINS PICKUP  
WASTEGATE TURBO UPGRADE  
INSTALLATION INSTRUCTIONS

TURBOCHARGER REMOVAL

(SEE FIG. 1 FOR COMPONENT IDENTIFICATION)

1. Position vehicle on a hoist. If no hoist is available, position vehicle on a flat level surface.
2. Disconnect the battery cables from the battery.
3. Disconnect the air inlet tube from air cleaner and exhaust pipe from the turbocharger.
4. Remove the two oil drain tube bolts from the turbocharger.
5. Disconnect the oil supply hose at the turbocharger.
6. Loosen the two hose clamps that connect the turbocharger to the air crossover pipe (or intercooler pipe on intercooled models).
7. Slide the connecting hose onto the turbocharger far enough to expose the gap between the turbocharger and the crossover pipe (or intercooler pipe).
8. Remove the turbocharger mounting nuts and the turbocharger from the exhaust manifold.

**CAUTION:** Anytime the turbocharger is removed from the engine, take care that no foreign objects enter any of the turbocharger connections on the engine or turbocharger. Foreign objects entering air, exhaust, or oil connections may cause major damage to the engine and/or turbocharger, and is not covered under any warranty. If the vehicle is intercooled, cover the open end of the intercooler pipe with a rag, as this pipe is very susceptible to foreign object entry.

9. Clean and inspect the exhaust flange mounting surfaces on the exhaust manifold. Remove any remaining gasket material from the turbocharger oil drain flange surface. Make sure surface is clean and dry.

10. If an exhaust gas pyrometer gauge is to be installed, refer to pyrometer installation instructions and install the pyrometer probe in the exhaust manifold at this time. (See separate section on pyrometer installation).

11. Raise front of vehicle and remove exhaust pipe support strap attached to engine.

12. Remove the U-clamp and separate the turbo exhaust pipe from the extension pipe. Heat from a torch may be required on the extension pipe slip joint to allow turbo exhaust pipe to be pulled free.

13. If the factory turbo exhaust pipe does not have a heat shield (near firewall) attached, go to step 16 and continue installation. If heat shield is present, continue with step 14.

14. Locate the rivets that attach the heat shield to the exhaust pipe. Use a small power drill with a 3/16 inch drill bit to drill out the rivets and remove the shield.

15. Reinstall the heat shield on the new Banks turbo exhaust pipe. Four 3/16 inch "POP" rivets are provided. See fig. 2.

16. Install the Banks turbo exhaust pipe in the existing extension pipe. A light lubricant and/or heat may be required to allow full engagement of the exhaust pipe into the slip joint. Do not clamp at this time. Reconnect the support strap.

NOTE: If the vehicle is a four wheel drive model and a Banks PowerPack exhaust system is to be installed at this time, skip over this step and install the Banks turbo exhaust pipe when the PowerPack® exhaust components are installed. The 4WD Banks PowerPack® system includes a new exhaust extension pipe.

#### TURBOCHARGER DISASSEMBLY AND REASSEMBLY

17. Clamp the exhaust inlet flange of the turbocharger in a bench vise. Loosen the four bolts, attaching the turbine housing to the center bearing section of the turbocharger. See fig. 3.

18. Remove the bolts, lockplates, and clampplates. Carefully remove the center bearing and compressor assembly from the cast iron turbine housing. If the turbocharger has been in service for some time, rust and carbon may prevent the center bearing and compressor assembly from easily separating from the turbine housing. If light hammer blows, penetrating oil, or heat will not free the compressor assembly from the turbine, the clamp bolt adjacent to the turbo oil inlet connection may be backed out so as to push against the bearing casting and separate the two components. Remove any loose rust or carbon from the bearing housing that might prevent proper engagement into the new turbine housing.

19. Install the center bearing and compressor assembly into the new turbine housing supplied in the Banks upgrade kit. Apply a dab of anti-seize compound to the bolts, then install bolts, clamp plates, and lock plates finger tight to allow for final positioning.

20. Clamp the exhaust inlet flange of the new turbine housing in a bench vise. Install the turbo exhaust outlet adapter casting to the turbine housing with five 8mm x 20mm metric hex bolts. Apply a dab of anti-seize compound to the bolts, then torque bolts to 11.3N-m (100 in.-lbs.). Make sure turbine inlet flange does not rotate in the vise while torquing. See fig. 4.

21. Make a mark on the turbocharger compressor housing directly adjacent to the oil inlet connection. This will allow you to reposition the compressor housing in this location once the V-band clamp is removed. See fig. 5.

22. Loosen the nut on the V-band clamp attaching the compressor housing to the turbo center section. Remove the V-band clamp from the turbo.

23. Loosen the nut on the new V-band clamp provided and slip the clamp onto the turbocharger. Note the position of the clamp bolt and nut in fig. 6. Rotate the clamp so that the actuator brace, provided in upgrade kit, may be installed between the tabs on the V-band clamp and the wastegate actuator bracket. See fig. 6. Attach the brace to the bracket with two 6mm x 10mm metric bolts and two 6mm washers. Rotate the V-band clamp until the brace aligns with the actuator bracket, then install a 6mm x 10mm metric bolt and 6mm washer to attach the brace to the actuator bracket. Leave all bolts finger tight.

24. Rotate the compressor housing to align the mark you made on the turbo compressor housing with the oil inlet fitting, then clamp the V-band nut to 8N-m (72 in.-lbs.). Tap against the clamp in four places around it's circumference. Once again tighten the clamp to the specified torque.



25. Spin the turbo compressor wheel to make sure it turns freely. If not, loosen the V-band clamp, find and correct the problem, and retighten as in the previous step.

#### TURBOCHARGER INSTALLATION

26. Remove the existing turbocharger oil drain tube from the engine.

27. Use a new gasket provided to connect the new turbocharger oil drain tube to the turbocharger. Make sure the turbocharger oil drain flange is clean and free of any old gasket material. Tighten the drain flange bolts to 24 n-m (18 ft.-lbs.) torque. NOTE: If bolts encounter excessive resistance prior to seating against the flange, check for paint build up in the threads of the turbo bearing housing. The threads may have to be chased with an 8mm x 1.25 metric tap.

28. Install a new turbo exhaust inlet gasket provided and apply a dab of anti-seize compound to the four turbo mounting studs. Make sure the turbo compressor hose is in place on the turbo, so it can be slid onto the crossover pipe or intercooler pipe. Install the turbocharger on the exhaust manifold. Slide the turbo oil drain tube into the hose on the engine. Tighten the turbocharger mounting nuts to 32N-m (24 ft. lbs.) torque.

29. Now tighten the turbine housing clamp plate bolts to 11.3N-m (100 in.-lbs.) torque.

30. Again spin the turbocharger shaft to make sure it turns freely. If not, loosen the turbine clamp plate bolts and check for misalignment between the turbine housing and turbocharger center section. Retighten bolts and check again.

31. Reconnect and tighten the turbo oil supply hose. Tighten the oil drain tube hose clamps.

32. Slide the turbo compressor hose onto the air crossover pipe or intercooler pipe. Center the hose over the gap between the turbocharger and the pipe, then position the clamps so they are behind (not over) the hose bead section of the turbo and pipe. Tighten the clamps to 5N-m (44 in.-lbs.) torque.

33. Install the air inlet tube (from air cleaner) and the turbo exhaust pipe onto the turbocharger. Tighten each of these clamps to 8 N-m (72in.-lbs.) torque. Make sure exhaust pipe is centered over V-band flange on turbocharger.

NOTE: If the vehicle is a 4WD model and a Banks PowerPack® exhaust system is being installed at this time, do not install and clamp the turbo exhaust pipe. It should be installed when installing the PowerPack.

34. The wastegate in the turbine housing is operated by boost pressure fed to the actuator through a hose from the intake system. This hose connection to the intake boost pressure will vary with vehicle model year and intercooled/non intercooled applications. Figure 7 shows three methods of connecting the wastegate actuator hose, choose the one that applies to your vehicle.

NOTE: When tapping the air crossover pipe on an '89-'91 non-intercooled engine, push a rag into the open end of the crossover pipe past the point to be drilled and tapped. This will prevent chips from entering the engine. Drill through the back side of the crossover pipe using a letter "R" drill, just above the turbo compressor hose joint. Tap this hole with an 1/8 N.P.T. pipe tap to accept the adapter fitting supplied. Use grease on the drill and tap to allow a minimum of chips to fall into the crossover pipe.

CAUTION! Make sure the rag is removed from the crossover pipe prior to reassembly and engine start up. Use a hooked tool (hook-screib or welding rod) to pull the rag from the crossover pipe. Inspect for and remove any remaining chips by placing a finger into the pipe opening and manually removing loose material.

35. Install the 1/8 pipe x 1/4 inch hose adapter fitting in the intake manifold connection selected from step 34 (fig. 7). Use Teflon tape or pipe sealant on fitting threads.

NOTE: If a manifold boost gauge is to be installed, an additional manifold pressure connection must be provided for the gauge. An 1/8 inch tee (not provided) must be installed at the intake manifold connection along with the 1/8 pipe x 1/4 hose adapter for a boost gauge connection.

36. Install a spring-band hose clamp onto one end of the 1/4 inch I.D. silicone hose (squeeze clamp with pliers and slide onto hose). Push this end of hose onto the hose nipple adapter fitting installed in step 35. Route the hose over the engine to the hose nipple on the wastegate actuator. Maintain 3-4 inches of clearance between the hose and exhaust manifold. Cable ties are provided to secure tubing to existing engine plumbing. (See fig. 7.)

CAUTION! Do not pull cable ties to tight as the hose may be pinched shut!

37. Trim hose as required to reach the wastegate actuator hose nipple. Slide a spring-band clamp onto the hose and attach hose to nipple. Make sure both hose clamps are positioned over the hose nipples. See fig. 8.

38. If a boost gauge is to be installed, complete the installation at this time. Follow the instructions included with the gauge.

39. If an exhaust gas pyrometer (temperature gauge) is to be installed, complete the wiring from the probe and install the gauge at this time.

40. Raise vehicle and tighten U-clamp at slip joint between turbo exhaust pipe and extension pipe.

NOTE: If the vehicle is a 4WD model and a Banks PowerPack® exhaust system is being installed at this time, skip this step as the PowerPack includes a new extension pipe. This step will be completed as part of the PowerPack assembly sequence. Reinstall turbo exhaust pipe when installing PowerPack system, torque V-band clamp to 8N-m (72 in.-lbs.).

41. Installation of the turbocharger upgrade package is now complete. If a Banks PowerPack exhaust system is to be installed at this time, that assembly may be commenced. Reconnect battery cables. Start vehicle and allow engine to warm up. Test drive vehicle and listen for any intake or exhaust leaks, correct as necessary.

GALE BANKS ENGINEERING  
DODGE/CUMMINS DIESEL PICKUP  
WASTEGATE TURBO UPGRADE

CUSTOMER BILL OF MATERIALS  
Kit # 24050

<u>QTY</u>	<u>DESCRIPTION</u>	<u>BANKS PART NO.</u>
1	CLAMP, V-BAND	24301
1	NUT, V-BAND	24302
5	BOLT, 8MM X 20MM HEX HEAD	24303
1	ADAPTER, EXHAUST OUTLET CONNECTOR	24304
1	ASSEMBLY, TURBINE HOUSING	24305-00
3	WASHER, 6MM I.D. FLAT	24306
1	BRACE, ACTUATOR	24327
3	BOLT, 6MM X 10 MM HEX	24328
1	GASKET, TURBO MOUNTING	93027
1	PIPE, TURBO EXHAUST	52109-00
1	HOSE, WASTEGATE ACTUATOR, 1/4" I.D. X 36", SILICONE	94121
1	ELBOW, 1/8 N.P.T. X 1/4 HOSE, 90°	92245
2	CLAMP, SPRING BAND HOSE, RED	92877
4	RIVET, POP, 3/16 DIA. X 1/8 GRIP	91998
1	TUBE, OIL DRAIN	24077-00
1	GASKET, OIL DRAIN	93040
2	PLAQUE, BANKS TURBOCHARGED	96003
4	TIE, CABLE 8"	62010
1	INSTRUCTION BOOKLET	96382
1	WARRANTY CARD	96380
1	WARRANTY STATEMENT	96381

# **banks**

Gale Banks Engineering 546 Duggan Avenue Azusa, California 91702 (818) 969-9605

FAX (818) 334-8078

## **FIG. 1**

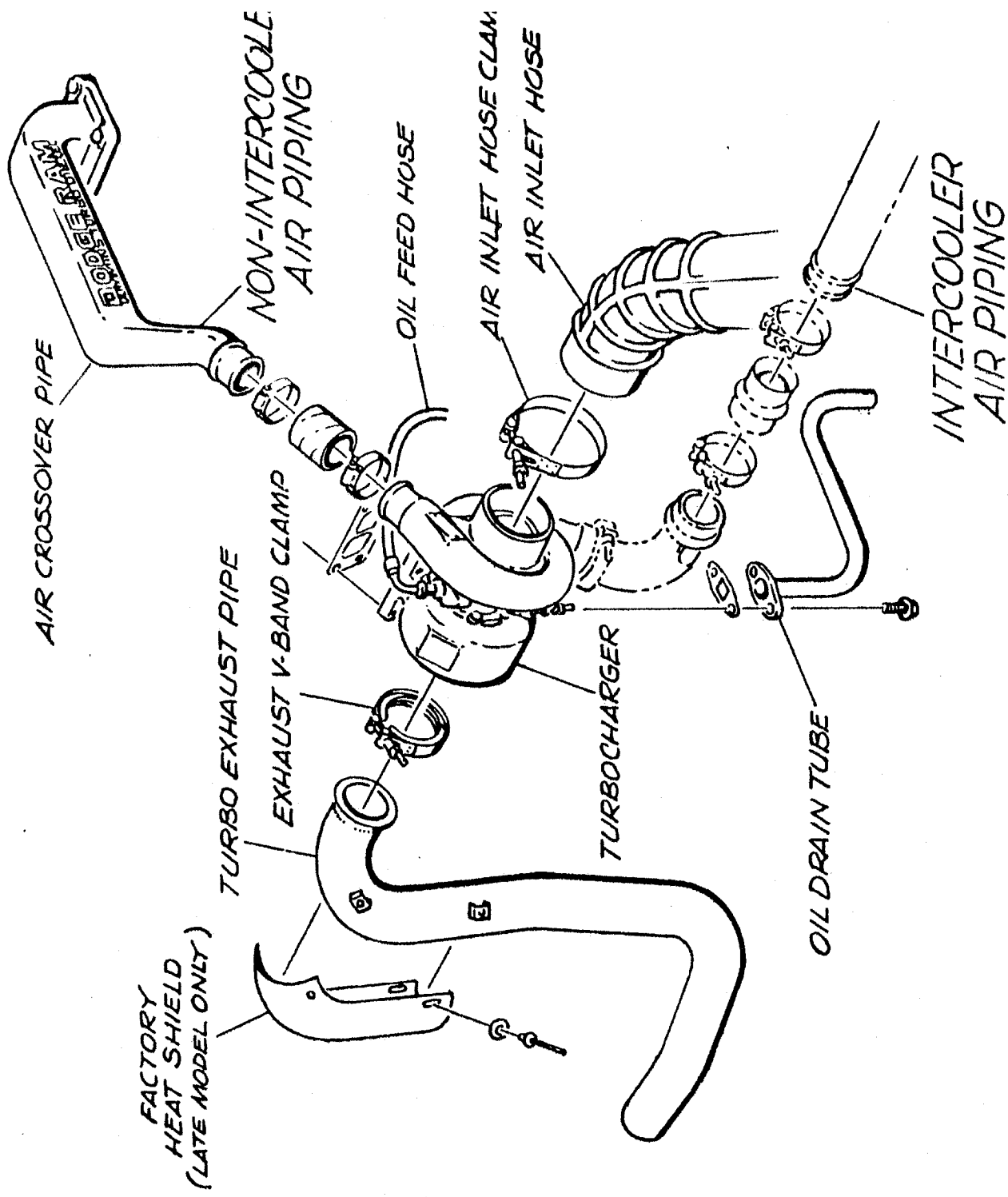

# FIG. 2 EXHAUST PIPE HEAT SHIELD (LATE MODEL ONLY)

FACTORY HEAT SHIELD  
(REMOVED FROM ORIGINAL  
EXHAUST PIPE)

BANKS TURBO EXHAUST PIPE

ORIGINAL WASHER  
(USE IN BOTTOM  
2 LOCATIONS  
ONLY)

"POP" RIVIT,  
4 LOCATIONS

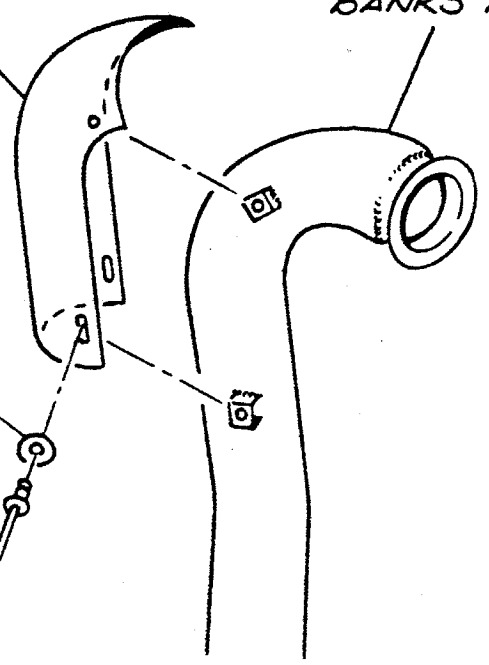

# FIG. 3

TURBO COMPRESSOR/BEARING  
ASSEMBLY

LOCKPLATES

CLAMPLATES

TURBINE HOUSING

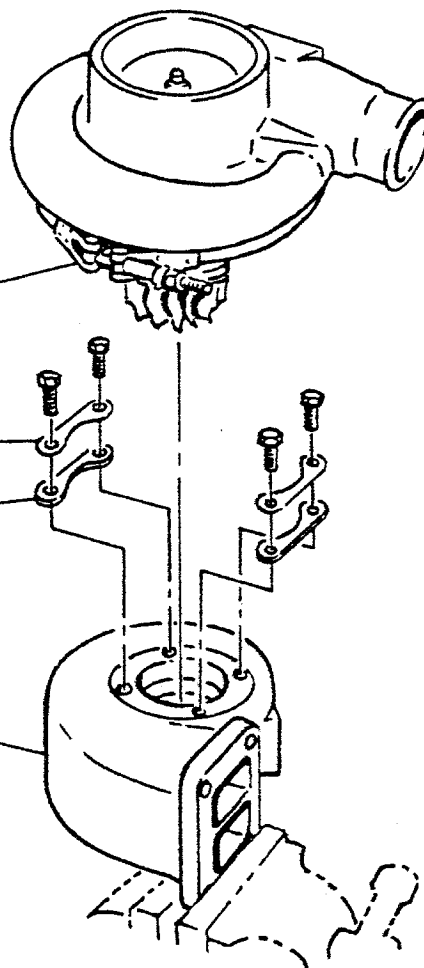

**FIG. 4**

EXHAUST OUTLET ADAPTER

8 MM X 20 MM HEX BOLT

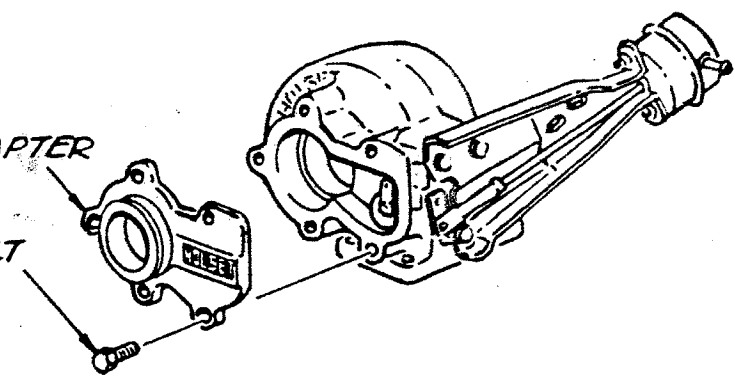

**FIG. 5**

MARK COMPRESSOR HOUSING (NOT CLAMP)  
ADJACENT TO OIL INLET CONNECTION.

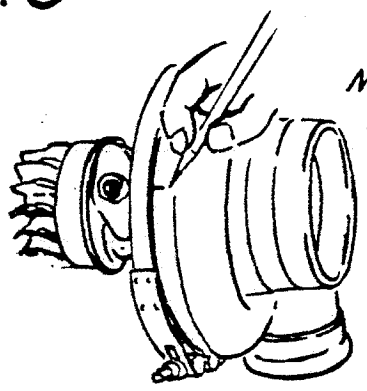

**FIG. 6**

COMPRESSOR COVER

O-RING

V-BAND CLAMP NUT

6MM X 10MM  
HEX BOLT

WASHER, 6MM I.D.

ACTUATOR BRACE

WASHER, 6MM I.D.

6MM X 10MM  
HEX BOLT

V-BAND  
CLAMP  
(SUPPLIED)

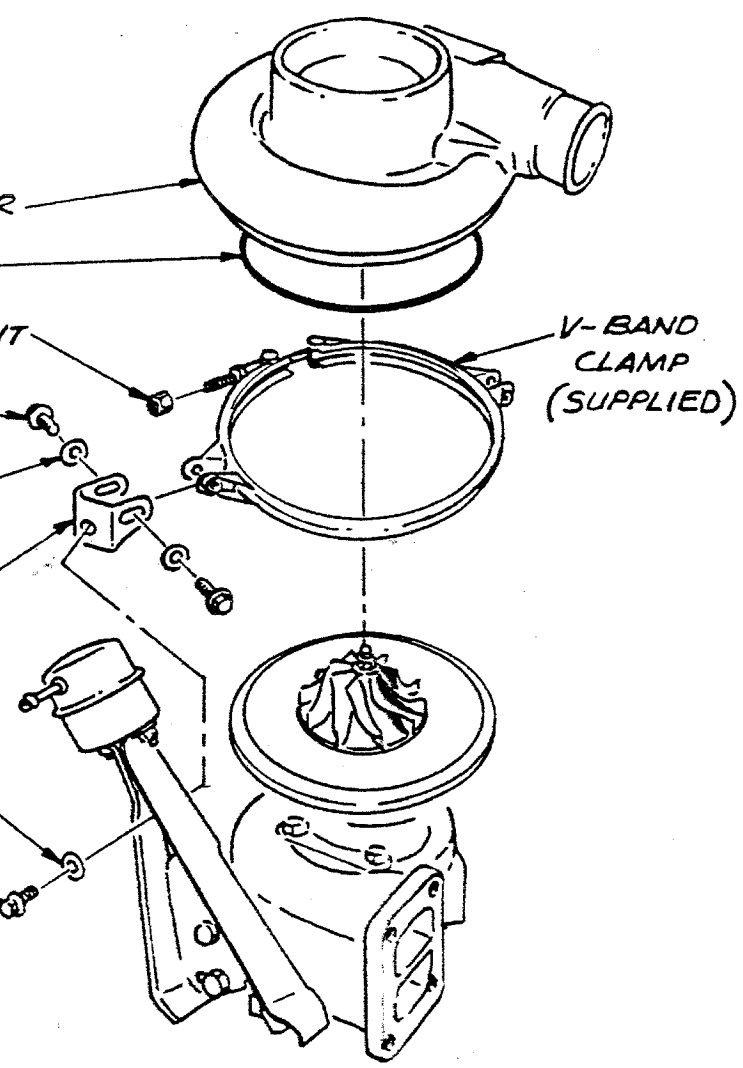

# FIG. 7 WASTEGATE ACTUATOR HOSE HOOK-UP

1991 1/2 AND LATER, INTERCOOLED

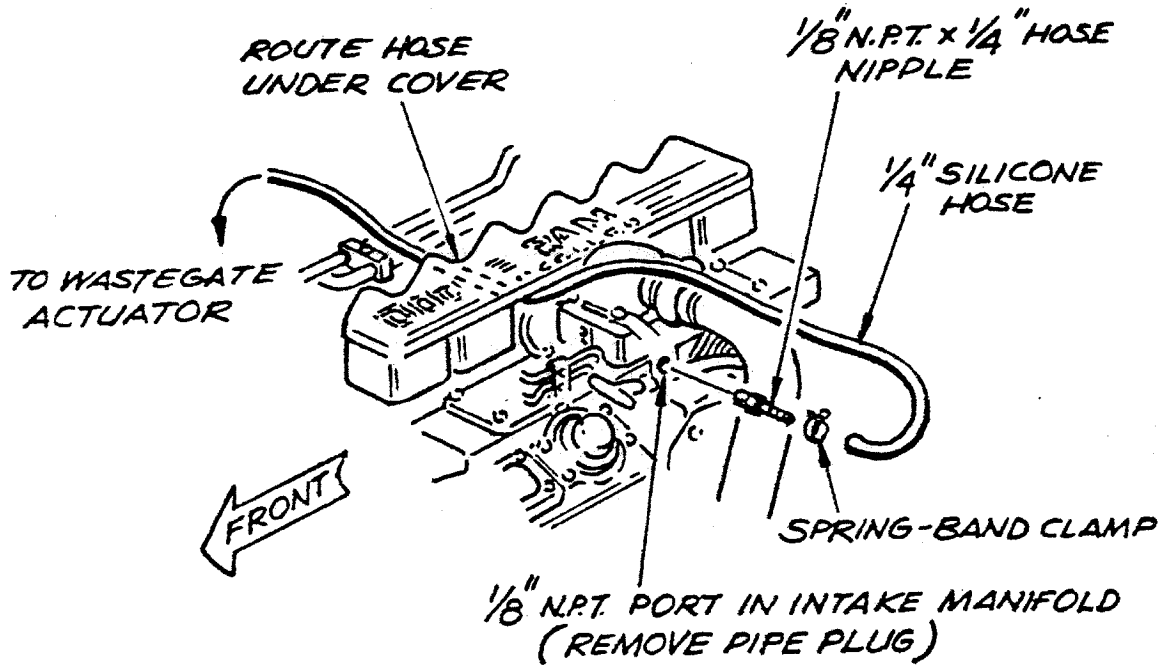

1989 - '91 NON-INTERCOOLED

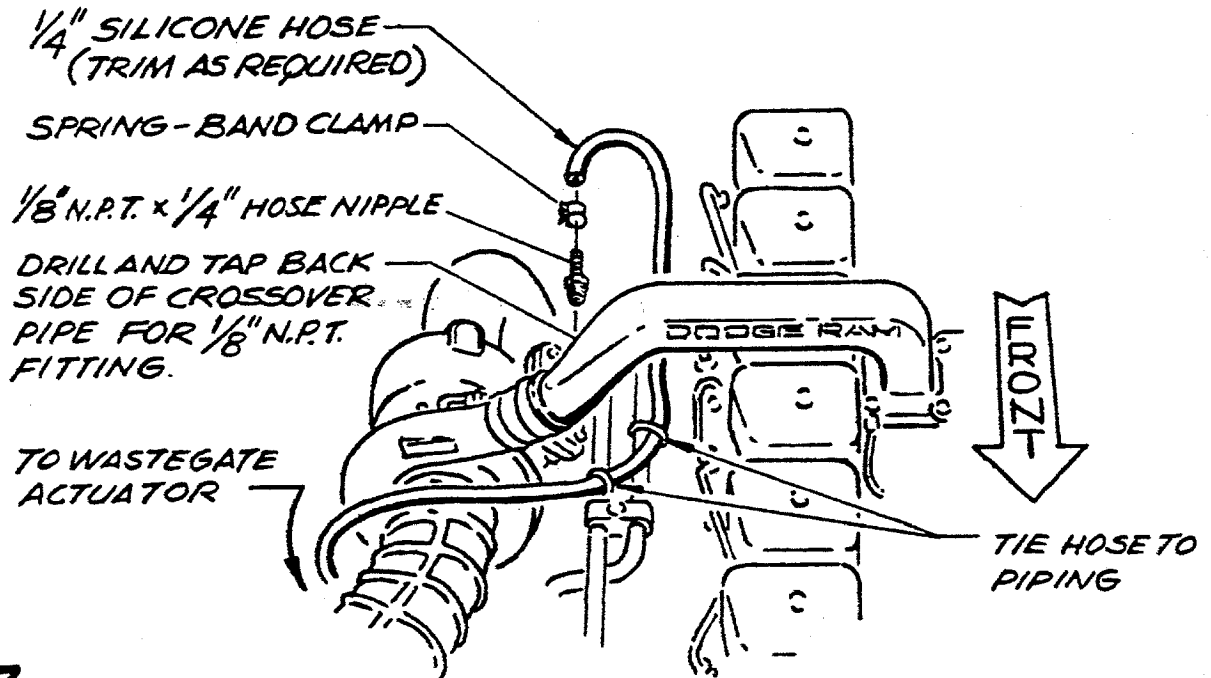

FIG. 7

CONTINUED NEXT PAGE



APPENDIX A

# FIG. 7 CONTINUED

1989-'91 WITH BANKS INTERCOOLER

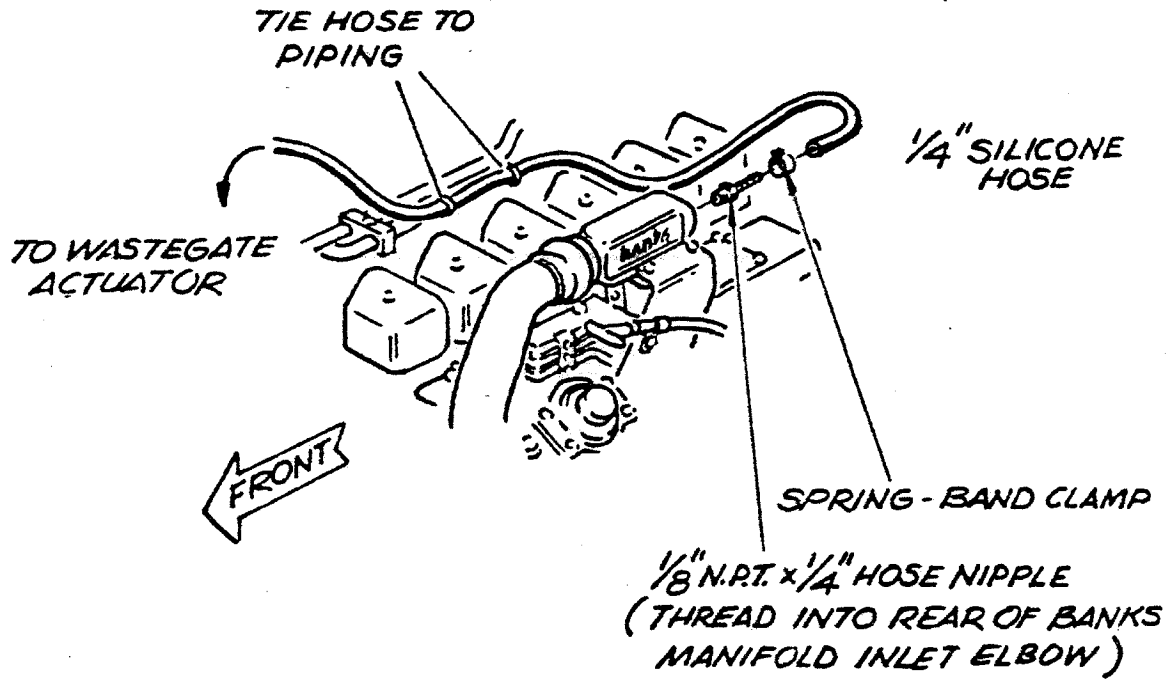

# FIG. 8

WASTEGATE ACTUATOR HOOK-UP

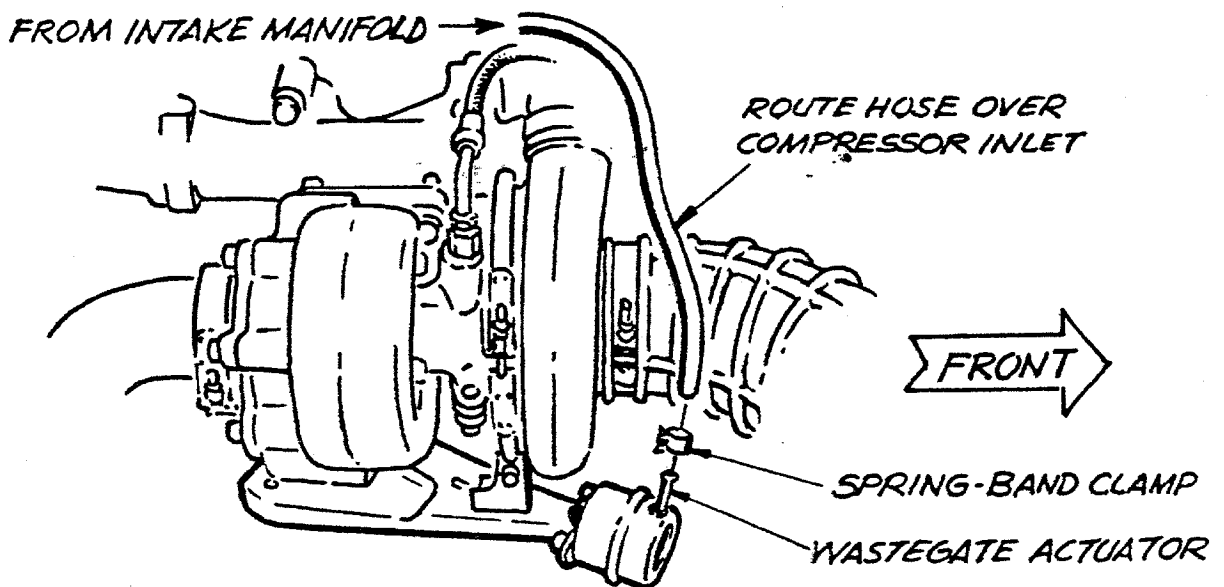

## DODGE/CUMMINS

### PYROMETER INSTALLATION INSTRUCTIONS

The optional exhaust gas pyrometer monitors the temperature of the exhaust entering the turbocharger turbine housing. Installation requires that the exhaust manifold be drilled and tapped for a temperature probe near the outlet of the manifold adjacent to the turbine housing. For this reason it is essential that the turbocharger be removed from the engine in order to clean out any metal chips from drilling that could cause turbine blade damage.

The Cummins 6BT engine uses a divided exhaust manifold and turbocharger. The pyrometer probe must be installed to sample exhaust temperature in one of the two exhaust passages. Typically the exhaust temperature will not differ appreciably between the two passages. We recommend installing the probe in the rear manifold passage to simplify routing the probe wiring.

1. Stuff a small shop towel or rag 4-5 inches into the rear exhaust manifold passage through the turbocharger mounting flange. This is to prevent chips from entering the manifold while drilling and tapping.

2. Drill through the exhaust manifold into the rear passage at the location shown in fig. x. Use a 7/16 inch drill, keep the drill perpendicular to the manifold surface.

3. Tap the drilled hole with a 1/4 NPT pipe tap. Check the thread depth as you tap by periodically removing the tap and screwing the probe fitting (supplied in pyrometer kit) into the tapped hole. The probe should thread in 3 - 3 1/2 turns hand tight. Do not install the probe in place at this time.

4. Remove as many loose chips as possible from the exhaust manifold. A shop vacuum, small brush, or fingers will help. Now remove the rag using a welding rod or coat hanger bent into a hook.

**WARNING!** Make sure rags are removed from exhaust manifold prior to reinstalling turbine housing!

5. Install the probe in the manifold (anti-seize on threads is recommended) and continue the pyrometer assembly as outlined in the instructions supplied with the pyrometer.

# PYROMETER PROBE INSTALLATION DODGE/CUMMINS TURBO DIESEL

DRILL AND TAP  $\frac{1}{4}$  N.P.T. PORT IN REAR  
PASSAGE OF EXHAUST MANIFOLD OUTLET

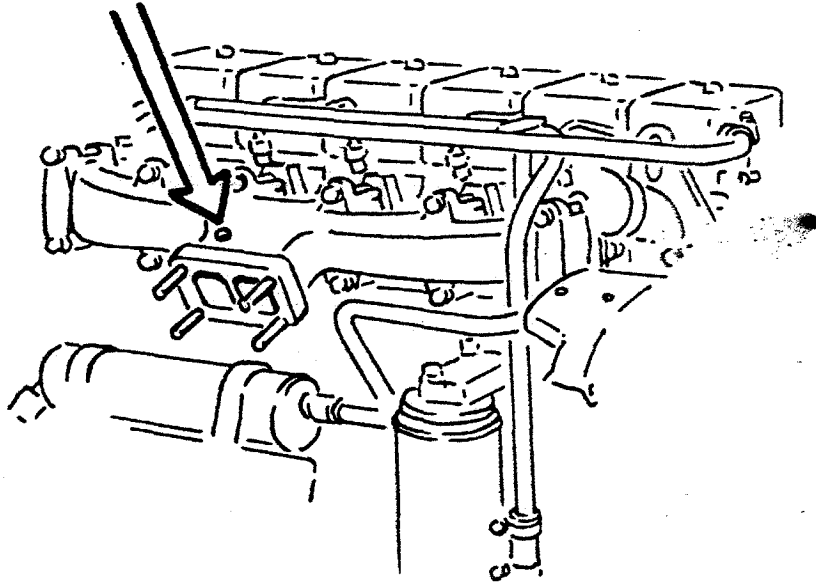

LOCATE PORT  $\frac{3}{4}$  INCH BEHIND  
FLANGE, CENTERED OVER REAR  
EXHAUST MANIFOLD PASSAGE

