

State of California  
AIR RESOURCES BOARD

EXECUTIVE ORDER D-175-3  
Relating to Exemptions Under Section 27156  
of the Vehicle Code

HYPERMAX ENGINEERING, INC.  
AIR-TO-AIR INTERCOOLER KIT

Pursuant to the authority vested in the Air Resources Board by Section 27156 of the Vehicle Code; and

Pursuant to the authority vested in the undersigned by Section 39515 and 39516 of the Health and Safety Code and Executive Order G-45-5;

IT IS ORDERED AND RESOLVED: That the installation of the add-on air-to-air intercooler kit manufactured by Hypermax Engineering, Inc. of 255 E. Route 72, Gilbert, Illinois 60136, has been found not to reduce the effectiveness of required motor vehicle pollution control devices, and therefore is exempt from the prohibitions of Section 27156 of the Vehicle Code for 1983-1992 turbocharged Ford Motor Company heavy-duty vehicles powered by a 6.9L/7.3L Navistar International heavy-duty diesel engine.

This exemption shall not apply to any device, apparatus, or mechanism advertised, offered for sale or sold with, or installed on, a motor vehicle prior to or concurrent with transfer to an ultimate purchaser.

This Executive Order is valid provided that installation instructions for this device will not recommend tuning the vehicle to specifications different from those submitted by the device manufacturer.

Changes made to the design or operating conditions of the device, as exempted by the Air Resources Board, that adversely affect the performance of a vehicle's pollution control system shall invalidate this Executive Order.

Marketing of this device using an identification other than that shown in this Executive Order or marketing of this device for an application other than those listed in this Executive Order shall be prohibited unless prior approval is obtained from the Air Resources Board. Exemption of a kit shall not be construed as an exemption to sell, offer for sale, or advertise any component of the product as an individual device.

This Executive Order does not constitute any opinion as to the effect that the use of this device may have on any warranty either expressed or implied by the vehicle manufacturer.

**THIS EXECUTIVE ORDER DOES NOT CONSTITUTE A CERTIFICATION, ACCREDITATION, APPROVAL, OR ANY OTHER TYPE OF ENDORSEMENT BY THE AIR RESOURCES BOARD OF ANY CLAIMS OF THE APPLICANT CONCERNING ANTI-POLLUTION BENEFITS OR ANY ALLEGED BENEFITS OF THE HYPERMAX ENGINEERING, INC.'S AIR-TO-AIR INTERCOOLER KIT.**

HYPERMAX ENGINEERING, INC.  
AIR-TO-AIR INTERCOOLER KIT

EXECUTIVE ORDER D-175-3  
(Page 2 of 2)

No claim of any kind, such as "Approved by the Air Resources Board" may be made with respect to the action taken herein in any advertising or other oral or written communications.

Section 17500 of the Business and Professions Code makes untrue or misleading advertising unlawful, and Section 17534 makes violation punishable as a misdemeanor.

Section 43644 of the Health and Safety Code provides as follows:

"43644, (a) No person shall install, sell offer for sale, or advertise or except in an application to the state board for certification of a device, represent, any device as a motor vehicle pollution control device for use on any used motor vehicle unless that device has been certified by the state board. No person shall sell, offer for sale, advertise, or represent any motor vehicle pollution control device as a certified device which, in fact, is not a certified device. Any violation of this subdivision is a misdemeanor."

Any apparent violation of the conditions of this Executive Order will be submitted to the Attorney General of California for such action as he deems advisable.

Executed at El Monte, California, this 25<sup>th</sup> day of August, 1992.

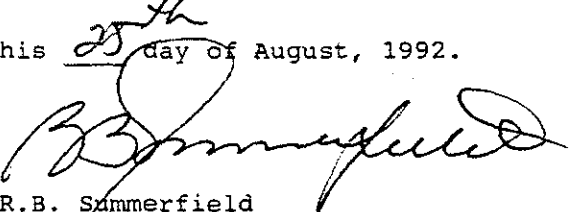
  
R.B. Summerfield  
Assistant Division Chief  
Mobile Source Division

State of California  
AIR RESOURCES BOARD

EVALUATION OF HYPERMAX ENGINEERING, INC.'S ADD-ON AIR-TO-AIR INTERCOOLER KIT  
FOR EXEMPTION FROM THE PROHIBITIONS OF VEHICLE CODE SECTION 27156  
IN ACCORDANCE WITH SECTION 2222, TITLE 13, OF THE  
CALIFORNIA CODE OF REGULATIONS

August 1992

State of California  
AIR RESOURCES BOARD

EVALUATION OF HYPERMAX ENGINEERING, INC.'S ADD-ON AIR-TO-AIR INTERCOOLER KIT  
FOR EXEMPTION FROM THE PROHIBITIONS OF VEHICLE CODE SECTION 27156  
IN ACCORDANCE WITH SECTION 2222, TITLE 13, OF THE  
CALIFORNIA CODE OF REGULATIONS

by

Mobile Source Division  
State of California  
Air Resources Board  
9528 Telstar Avenue  
El Monte, CA 91731-2990

(This report has been reviewed by the staff of the California Air Resources Board and approved for publication. Approval does not signify that the contents necessarily reflect the views and policies of the Air Resources Board, nor does mention of trade names or commercial products constitute endorsement or recommendation for use.)

SUMMARY

Hypermax Engineering, Inc. (Hypermax) of 255 E. Route 72, Gilberts, Illinois 60136, has applied for an exemption from the prohibitions in Section 27156 of the California Vehicle Code (VC) for their add-on intercooler kit for 1983-1987 Ford Motor Company vehicles powered by the Navistar International 6.9L heavy-duty diesel engine and 1988-1992 model-year Ford Motor Company vehicles powered by a 7.3L Navistar International heavy-duty diesel engine.

Hypermax has submitted a completed application and all the necessary information for exemption. Based on previous comparative tests evaluating the exhaust emissions effects of several add-on intercooler systems and the staff's evaluation of the intercooler's impact on exhaust emissions from turbocharged vehicles, the staff concludes that the Hypermax's intercooler system will not adversely affect exhaust emissions from vehicles for which the exemption is requested.

The staff recommends that Hypermax be granted an exemption as requested and that Executive Order D-175-3 be issued.

TABLE OF CONTENTS

	Page Number
SUMMARY	i
CONTENTS	ii
I. INTRODUCTION	1
II. CONCLUSION	1
III. RECOMMENDATION	1
IV. INTERCOOLER KIT DESCRIPTION	1
V. DISCUSSION	2
APPENDIX A: INSTALLATION INSTRUCTIONS AND PART NUMBERS	4

EVALUATION OF HYPERMAX ENGINEERING, INC.'S ADD-ON AIR-TO-AIR INTERCOOLER KIT  
FOR EXEMPTION FROM THE PROHIBITIONS OF VEHICLE CODE SECTION 27156  
IN ACCORDANCE WITH SECTION 2222, TITLE 13, OF THE  
CALIFORNIA CODE OF REGULATIONS

I. INTRODUCTION

Hypermax Engineering, Inc. (Hypermax) of 255 E. Route 72, Gilberts, Illinois 60136, has applied for an exemption from the prohibitions in Section 27156 of the California Vehicle Code (VC) for their add-on air-to-air intercooler kit for 1983-1987 Ford Motor Company vehicles powered by the Navistar International 6.9L heavy-duty diesel engine and 1988-1992 model-year Ford Motor Company vehicles powered by a 7.3L Navistar International heavy-duty diesel engine.

II. CONCLUSIONS

Based on previous comparative tests evaluating the effects of several add-on intercooler systems on exhaust emissions and the staff's evaluation of the intercooler impact on exhaust emissions from turbocharged vehicles, the staff concludes that the Hypermax's intercooler system will not adversely affect exhaust emissions from vehicles for which the exemption is requested.

III. RECOMMENDATION

The staff recommends that Hypermax be granted an exemption for their add-on air-to-air intercooler system as requested and that Executive Order D-175-3 be issued.

IV. INTERCOOLER KIT DESCRIPTION

The purpose of the Hypermax intercooler system is to reduce the temperature of the intake air charge into the turbocharged engine. This reduction in the intake charge temperature allows a greater charge density (more mass of air flowing through the engine) to enter the combustion chamber which means more fuel into the engine at any given intake manifold pressure and, therefore, more power output of the engine. Also, the reduction in the intake charge temperature would result in lower combustion/exhaust temperature.

The major components of the air-to-air intercooler system include a heat exchanger and inter-connecting bent tubing along with the necessary nuts, bolts, clamps, washers and brackets necessary to assemble the kit. The compressed air from the turbocharger enters the heat exchanger which uses ambient air as a cooling medium. The air-to-air heat exchanger is located in such a way that the heated charge air flows through one section and ambient air flows through the other section, cooling the heated compressed charge air. The cooled compressed air is then passed out of the heat exchanger to the throttle(s) for induction into the engine. There will be a pressure drop when the air passes through the heat exchanger which varies depending on the size of the heat exchanger, the temperature of the cooling medium (ambient air) and the available flow rate of the cooling medium.

The inlet and outlet pipes of the Hypermax air-to-air intercooler kit are made from steel tubing. No emission control components are removed, disconnected or relocated when the air-to-air intercooler kit is installed. Installation instructions, included in every kit, show how to properly install the Hypermax intercooler kit. Appendix A shows the installation instructions including the part numbers.

#### V. DISCUSSION

The Hypermax add-on air-to-air intercooler is designed for installation on 1983-1987 Ford Motor Company vehicles powered by a 6.9L Navistar International heavy-duty diesel engine and 1988-1992 model-year Ford Motor Company vehicles powered by a 7.3L Navistar International heavy-duty diesel engine. Hypermax's intercooler kit is similar in design concepts and principles as other manufacturers' systems that have been exempted by the Air Resources Board. According to the performance analysis previously submitted by other manufacturers seeking exemption, the thermal efficiency of the intercooler system ranges between 40 percent and 84 percent.



Based on predicted efficiency of a heat exchanger and a review of the intercooler kit, the staff believes that the Hypermax's add-on air-to-air intercooler kit will not adversely affect a turbocharged vehicle's emissions or degrade a vehicle's driveability.

APPENDIX A

**HYPERMAX ENGINEERING, INC.**

**6.9/7.3L INTERCOOLER PACKAGE**

**I N S T A L L A T I O N   I N S T R U C T I O N S**

Time will be saved if these instructions are read PRIOR to installation of the intercooler package.

**A. ITEMS TO BE REMOVED:**

1. Negative battery cables
2. Bumper 1983-86. Bumper/Reinforcement/Bracket Ass'y 1987-91
3. Radiator grille
4. Headlight trim (both sides) 1983-86
5. Stone deflector
6. Hood latch
7. Outer radiator grille support
8. Air filter and air cleaner mount
9. Top grille cover
10. Intake manifold cover

**B. MOUNTING INTERCOOLER:**

1. If the vehicle is equipped with an optional or aftermarket transmission oil cooler, temporarily move it out of the way and then relocate it after the intercooler is installed.
2. Provide pass thru holes in the radiator support for the air pipes to and from the intercooler by referring to Fig. 1. Use 3" hole saw.
3. Cut or grind BOTH front and rear radiator side support flanges so hole in support bracket is unobstructed. Push air conditioning condenser as close to radiator as possible.
4. Install rubber isolation mounts on outside of intercooler mounts.
5. Install right angle intercooler mounts on other end of rubber isolation mount and hand tighten. (Note: 5/16" diameter holes should face towards outside of vehicle.)
6. Hold intercooler in place with pipe protruding THROUGH CENTER of 3" hole cut in radiator support bracket. Level intercooler and mark the (4) holes for the mounting brackets, keeping brackets as low as possible. Remove intercooler/bracket assembly.
7. Drill the (4) 1/4" diameter holes through.
8. Screw 5/16" diameter self-tapping sheet metal bolts into holes to cut threads.

Trial fit intercooler as needed.

10. For trucks with air-conditioning, remove bracket on the RIGHT side of the condenser and bend the condenser line back. Re-install the bracket UPSIDE DOWN. (NOT APPLICABLE FOR 1987-1991 VEHICLES)
11. Re-install intercooler on truck.
12. Locate lower mount on left bottom of intercooler. Mark through hole to locate on radiator support frame.
13. Remove intercooler, drill 3/8" diameter hole thru frame for lower mount. (Note: Be careful not to damage radiator.)
14. Grind or cut support frame for clearance of HYI-2 pipe per Fig. 1. Also grind rear side of support bracket on radiator for pipe clearance as on above hole.

C. INSTALLATION OF PIPES AND INTAKE COVER:

1. Install intake manifold cover with its "O" ring (apply grease to "O" ring). Retain LIGHTLY with 3/8" NC x 4" bolt with "O" ring washer and backup washer.
2. Remove 3/8" bolt from outside of fuel filter mount.
3. Oil dipstick tube must be bent outwards for lower pipe (HYI-3) clearance. For 1985-86 trucks with mount over valve cover, remove and relocate it back (1 set) of valve cover holes. Note: For 1987-91 vehicles, relocate to the bottom set of bolts and use bracket provided.
4. Install lower cold pipe (HYI-3) without hose on intake cover. Check for clearance with fuel line heater, air conditioning equipment, horn, battery cables, etc. If there is interference, bend or cable-tie as required. (Note: This is a TRIAL-FIT step.)
5. Install upper hot pipe (HYI-1) noting clearance with the above mentioned parts.
6. Install upper mount strap on the front of the fuel filter mount support bracket with 3/8" bolt. Connect strap to upper hot pipe (HYP-1) bracket with (2) 1/4" bolts, nuts, and lock washers. Tighten bolts and nuts after best alignment is achieved. Install 1/4" NC bolt into bracket which holds (2) pipes together.
7. Align intake cover with pipes in place. Tighten clamps and 3/8" bolt on cover.

8. Remove pipes - install hoses with clamps on pipe. (Note: make sure lower clamps are FACING UP on the outside of the pipe. Re-install pipes, sliding hoses over intake cover. Tighten upper hose clamps and bolts.
9. Re-install air filter mount and air filter.

**D. FINAL INTERCOOLER INSTALLATION:**

1. Install lower rubber isolation mount into frame with 3/8" nut and lock washer.
2. Re-install intercooler inserting 2-1/4" dia. inlet into hose on upper hot pipe (HYI-1). Install upper mount brackets with 3/8" nuts and lock washers on rubber isolation mount studs.
3. Push intercooler back against lower mount. Shim mount with washers provided so as to have a minimum of 1/4" clearance at all points. Install 3/8" nut with lock washer.
4. Install front connecting pipe (HYI-2) with hoses at both ends. Mark radiator support frame. Remove pipe and drill 1/4" diameter hole. CAP THE PIPE OPENING while drilling.
5. Screw 5/16" self-tapping sheet metal bolt into hole to cut threads.
6. Re-install front connector pipe (HYI-2). Tighten ALL clamps.

**E. MODIFICATION OF FRONT END COMPONENTS:**

**OUTER RADIATOR GRILLE SUPPORT:** Cut-off 2-3/4" below top. Discard lower piece. Remount on radiator support frame.

**TOP GRILLE COVER:** Trim as required to clear hood latch and intercooler brackets. 1987-91 vehicles, secondary latch handle must be cut by approximately 1" and bent outward 90°.

**STONE DEFLECTOR:** Cut off center tab flush.

**1983-86 -** Re-install top grille cover, molding and headlight trim (both sides). Rear of grille assembly may have to be cut so it can be reinstalled. The top grille cover must be trimmed around intercooler mounts. The front deflector panel and lower trim strip are eliminated with installation of the intercooler.

**1987-91 -** Additional clearance must be provided between the grille and radiator/cooler assemblies by spacing the grille forward with spacers, bolts, washers, and nylock nuts provided. Bolt holes in headlamp housing (RH and LH) must be enlarged to 11/32" where grille mounts. Transfer holes to grille support. Note: clips on grille are no longer utilized. The front deflector panel may have to be trimmed around the intercooler brackets and hood latch assembly.

**F. FINAL FRONT END ASSEMBLY:**

1. Install stone deflector.
2. Install bumper, check for clearance with intercooler.  
1983-86 vehicles, space bumper out with washers between frame and bumper as required.
3. Adjust hood latch per Ford Manual.

**OPERATING NOTE:**

Oil from the crankcase breather system may accumulate in the intercooler core after an extended period of time (15,000 - 20,000 miles) and cause a REDUCTION IN TURBOCHARGER BOOST. DO NOT CONFUSE THIS CONDITION WITH LOW BOOST DUE TO A CONTAMINATED AIR OR FUEL FILTER.

If the intercooler is diagnosed as being oil restricted, simply flush the interior with a petroleum solvent.

PARTS LIST - FORD PICK-UP TRUCK INTERCOOLER PACKAGE

<u>Line No.</u>	<u>Qty.</u>	<u>Description</u>
1	(1)	Assembly - intercooler
2	(1)	Cover - intake manifold
3	(3)	Mount - rubber isolation
4	(1)	Strap - upper mount (1983-88)
5	(1)	Strap - upper mount (1989-92)
6	(1)	Bracket - upper hanger (right hand)
7	(1)	Bracket - upper hanger (left hand)
8	(1)	Bracket - oil dipstick tube (1987-92)
9	(5)	Hose - (2-1/4" dia. x 3-1/4" lgth.)
10	(10)	Clamp - hose (2-1/4" dia.)
11	(5)	Bolt - self-tapping sheet metal (5/16" dia.)
12	(1)	Pipe - upper hot (HYI-1)
	(1)	Pipe - front connector (HYI-2)
14	(1)	Pipe - lower cold (HYI-3)
15	(2)	Nut - (1/4" NC)
16	(1)	Nut - (5/16" NC)
17	(6)	Nut - (3/8" NC)
18	(3)	Washer - lock (1/4")
19	(1)	Washer - lock (5/16")
20	(6)	Washer - lock (3/8")
21	(3)	Washer - flat (3/8" dia.)
22	(8)	Washer - flat (5/16") (1987-1992)
23	(3)	Bolt - (1/4" NC x 3/4")
24	(1)	Bolt - (5/16" NC x 1")
25	(4)	Bolt - (5/16" NC x 2") (1987-1992)

<u>Line No.</u>	<u>Qty.</u>	<u>Description</u>
26	(1)	O-ring - intake cover
27	(4)	Nylock (5/16) (1987-1992)
28	(4)	Grille Spacers (3/4" x 1") (1987-1992)
29	(1)	Instructions - installation

**HYPERMAX ENGINEERING, INC.**  
255 E. RT. 72  
GILBERTS, IL 60136  
(708) 428-5655



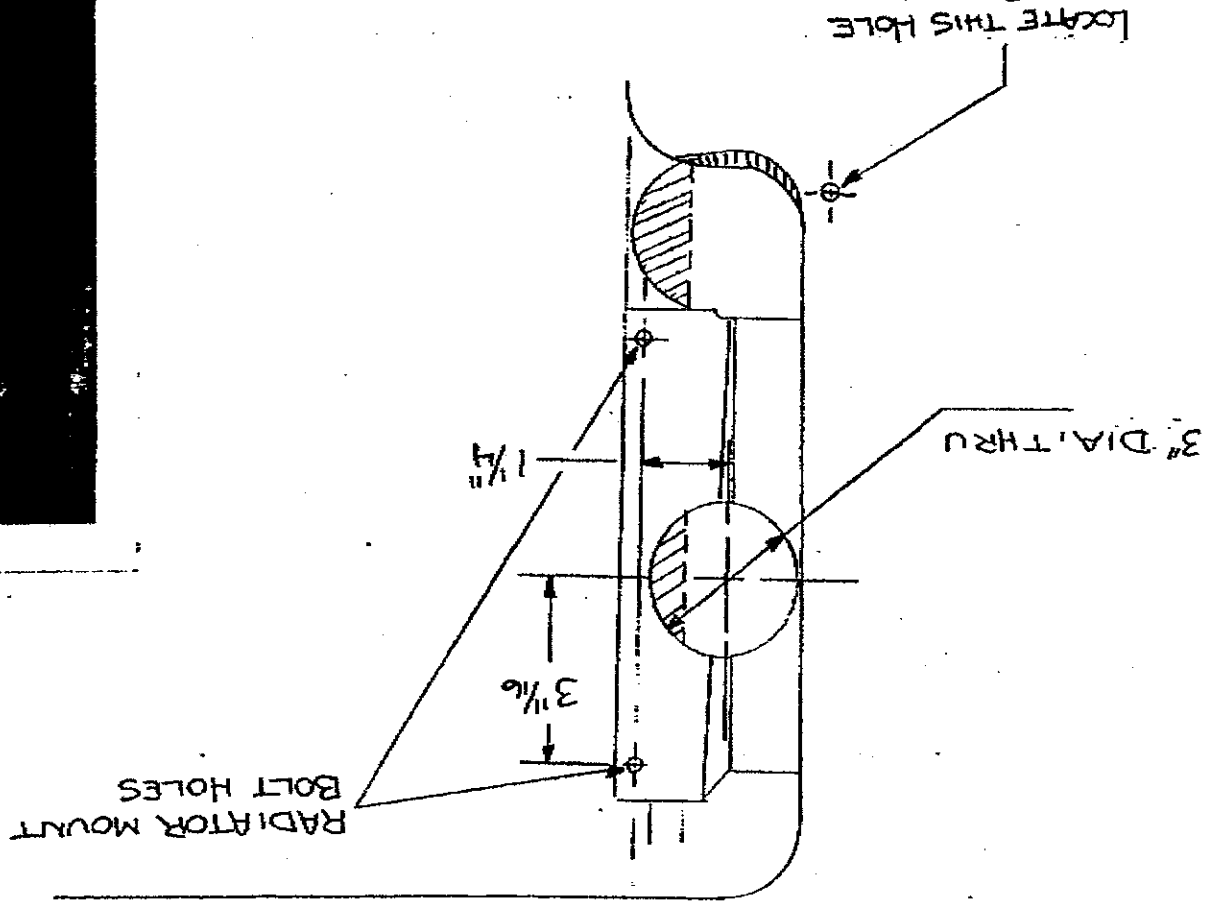

LOCATE THIS HOLE  
WITH FRONT CONNECTOR  
PIPE (HYI-2) IN PLACE  
AFTER GRINDING SHADED  
AREA. DRILL 1/4" THRU FOR  
5/16" SELF TAPPING SHEET  
METAL BOLT

FRONT

Fig. 1

DIVISION OF HIGHWAY SAFETY, INC. S  
DIESEL CONTROLLER FOR AN EXEMPTION FROM THE PROHIBITIONS OF VEHICLE CODE  
SECTION 27156 IN ACCORDANCE WITH SECTION 2222, TITLE 13, OF THE  
CALIFORNIA CODE OF REGULATIONS

I. INTRODUCTION

Hypermax Engineering, Inc. of 255 E Route 72, Gilberts, Illinois 60136 has applied for an exemption from the prohibitions in Section 27156 of the California Vehicle Code (VC) for their Diesel Controller for 1993-97 trucks equipped with a turbocharged Navistar 7.3L diesel engine.

II. CONCLUSIONS

Based on submitted emissions test data, the staff concludes that Hypermax Engineering, Inc.'s Diesel Controller will not adversely affect exhaust emissions from the vehicles for which the exemption is requested.

III. RECOMMENDATION

The staff recommends that Hypermax Engineering, Inc. be granted an exemption for their Diesel Controller for installation on 1993-97 trucks equipped with a turbocharged Navistar 7.3L diesel engine. The staff also recommends that Executive Order D-175-12 be issued.

IV. DIESEL CONTROLLER DESCRIPTION

The Diesel Controller manufactured by Hypermax Engineering has been specifically designed for installation on 1993-97 trucks equipped with a turbocharged Navistar 7.3L diesel engine.

The purpose of using Hypermax's Diesel Controller is to enhance the performance of the 7.3L diesel engine during high torque and wide open throttle conditions (WOT).

The new electronic control module (ECM), the Hypermax Diesel Controller, is a direct replacement ECM that has been modified. The modifications made are designed to interface with the existing software and hardware to improve the performance of the engine. The principal idea behind the modifications is to increase the injector pulse width and allow more fuel to be delivered to the engine during 50 percent or greater throttle position. The manufacturer claimed that by increase the pulse width at 50 percent throttle, the driver would not experience any sudden surge in power that may result if the injector pulse width is increased at or near WOT. Hypermax claims that these trucks are usually used for long haul travel and do not exceed the 50 percent throttle position during normal driving. Since these trucks are factory turbocharged and usually are equipped with manual

transmissions, throttle position between 50 and 100 percent is rarely used, except for high load and acceleration conditions.

V. DISCUSSION OF THE DIESEL CONTROLLER

A 1995 Ford F-350 equipped with a 7.3L turbocharged diesel engine was used for the evaluation of the Diesel Controller. Testing consisted of one Cold 505 in the baseline configuration and one Cold 505 in the modified configuration. The dynamometer inertia weight and horsepower settings were 8000-lbs. and 19.3-hp., respectively. The emissions testing was conducted by Roush Laboratories for Hypermax, data was evaluated against the vehicles's baseline emission levels. Table 1 list those results.

Table 1.

	(gm/mile)			
	HC	CO	NOx	Particulates
Baseline	0.89	4.68	7.8	0.15
Modified	0.84	4.46	7.4	0.16

The ARB did not perform testing to confirm the emission test results submitted by the applicant. Emission test results submitted were below the vehicle's baseline emission levels or within the allowable increases of 0.1 grams/mile or 10 percent on HC or NOx, 1.0 grams/mile or 15 percent on CO, and 0.03 grams/mile or 15 percent on Particulates.

In addition to their emissions evaluation Roush also performed a key on engine off (KOEO) test and a key on engine running (KOER) test with the vehicle in the baseline and modified configuration. Hypermax used a new 1997 Ford F-350 truck with the 7.3L diesel engine to evaluate the affect of the device on the vehicle's limited on-board diagnostic (OBD) II system. The OBD II system was introduced only on medium-duty diesels trucks in 1997. No codes were detected and the vehicle's monitors completed their check. An incomplete monitor would mean that the vehicle's computer had not been able to complete its evaluation of the sensors associated with that monitor. Therefore, based on the test results and the OBD II checks, the staff concludes that the installation of the Diesel Controller will not have an adverse effect on exhaust emissions on those applicable vehicles.

Hypermax Engineering has submitted all the required information and fulfilled the requirements for an exemption.