

State of California
AIR RESOURCES BOARD

EXECUTIVE ORDER D-176-2
Relating to Exemptions Under Section 27156
of the Vehicle Code

DINAN ENGINEERING, INC.
PERFORMANCE CHIP

Pursuant to the authority vested in the Air Resources Board ("ARB") by Section 27156 of the Vehicle Code; and

Pursuant to the authority vested in the undersigned by Sections 39515 and 39516 of the Health and Safety Code and Executive Order G-45-5;

IT IS ORDERED AND RESOLVED: That the installation of the performance chip manufactured by Dinan Engineering, Inc. ("performance chip") has been found not to reduce the effectiveness of required motor vehicle pollution control devices and, therefore, is exempt from the prohibitions of Section 27156 of the Vehicle Code for those applications listed in Exhibit A, which is attached hereto and incorporated herein.

This Executive Order is valid provided that installation instructions for this performance chip will not recommend tuning the vehicle to specifications different from those submitted by the device manufacturer.

Changes made to the design or operating conditions of the device, as exempted by the ARB, that adversely affect the performance of a vehicle's pollution control system shall invalidate this Executive Order.

Marketing of this device using an identification other than that shown in this Executive Order or marketing of this device for an application other than those listed in this Executive Order shall be prohibited unless prior approval is obtained from the Air Resources Board. Exemption of a kit shall not be construed as an exemption to sell, offer for sale, or advertise any component of a kit as an individual device.

This Executive Order does not constitute any opinion as to the effect the use of this device may have on any warranty either expressed or implied by the vehicle manufacturer.

This Executive Order is granted based on results from emissions tests conducted in accordance with Cold-Start CVS-75 Federal Test Procedure. However, the ARB finds that reasonable grounds exist to believe that use of the performance chip may adversely affect emissions of motor vehicles when operating under conditions outside the parameters of the previously prescribed test procedures. Accordingly, the ARB reserves the right to conduct additional emission tests, in the future, as such tests are developed, that will more adequately measure emissions from all cycle phases. If such test results demonstrate that the performance chip adversely affects emissions during off-cycle conditions (defined as those conditions which are beyond the parameters of the Cold-Start CVS-75 Federal Test Procedure), this Executive Order shall be effectively rescinded as of the date the test results are validated. Further, if such test results or

other evidence provides the ARB with reason to suspect that the performance chip will affect the durability of the emission control system, Dinan Engineering, Inc. shall be required to submit durability data to show that the durability of the vehicle emission control system is not, in fact, affected and/or that the add-on or modified part demonstrates adequate durability.

In addition to the foregoing, the ARB reserves the right in the future to review this Executive Order and the exemption provided herein to assure that the exempted add-on or modified part continues to meet the standards and procedures of Title 13, California Code of Regulations section 2222 et seq.

THIS EXECUTIVE ORDER DOES NOT CONSTITUTE A CERTIFICATION, ACCREDITATION, APPROVAL, OR ANY OTHER TYPE OF ENDORSEMENT BY THE AIR RESOURCES BOARD OF ANY CLAIMS OF THE APPLICANT CONCERNING ANTI-POLLUTION BENEFITS OR ANY ALLEGED BENEFITS OF DINAN ENGINEERING, INC.'S PERFORMANCE CHIP.

No claim of any kind, such as "Approved by the Air Resources Board" may be made with respect to the action taken herein in any advertising or other oral or written communication.

Section 17500 of the Business and Professions Code makes untrue or misleading advertising unlawful, and Section 17534 makes violation punishable as a misdemeanor.

Section 43644 of the Health and Safety Code provides as follows:

"43644, (a) No person shall install, sell, offer for sale, or advertise, or, except in an application to the state board for certification of a device, represent, any device as a motor vehicle pollution control device for use on any used motor vehicle unless that device has been certified by the state board. No person shall sell, offer for sale, advertise, or represent any motor vehicle pollution control device as a certified device which, in fact, is not a certified device. Any violation of this subdivision is a misdemeanor."

Any apparent violation of the conditions of this Executive Order may result in its rescission or submission to the Attorney General of California for such action as he deems advisable.

Executed at El Monte, California, this 13th day of May, 1991.



R. B. Summerfield
Assistant Division Chief
Mobile Source Division

EXHIBIT A

9. List the names, model years, engine displacements and systems that are compatible with the device, and for which exemption is requested. Specify the correct device model for each vehicle.

<u>Make</u>	<u>Model</u>	<u>Years</u>	<u>Displ</u>	<u>ECU Number</u>	<u>Dinan Engineering Performance Chip *</u>
BMW	318is	90-91	1.8	0-261-200-175	D900-1833
BMW	325e	85-87	2.7	0-261-200-027	D900-2711
BMW	325i	87-88	2.5	0-261-200-153	D900-2531
BMW	325i	89-91	2.5	0-261-200-173	D900-2532
BMW	325i	89-91	2.5	0-261-200-380	D900-2533
BMW	M-3	88-91	2.3	0-261-200-071	D900-2321
BMW	525i	89-91	2.5	0-261-200-173	D900-2532
BMW	525i	89-91	2.5	0-261-200-524	D900-2534
BMW	528e	85-87	2.7	0-261-200-027	D900-2711
BMW	533i	84	3.2	0-261-200-008	D900-3311
BMW	535i	85-87	3.4	0-261-200-059	D900-3521
BMW	535i	88	3.4	0-261-200-059	D900-3522
BMW	535i	89-91	3.4	0-261-200-179	D900-3532
BMW	M-5	84-88	3.5	0-261-200-055	D900-3420
BMW	M-5	87-88	3.5	0-261-200-079	D900-3421
BMW	M-5	90-91	3.6	0-261-200-350	D900-3631
BMW	633csi	84	3.2	0-261-200-008	D900-3311
BMW	635csi	85-87	3.4	0-261-200-059	D900-3521
BMW	635csi	88	3.4	0-261-200-150	D900-3531
BMW	635csi	89	3.4	0-261-200-179	D900-3532
BMW	M-6	84-88	3.5	0-261-200-055	D900-3420
BMW	M-6	87-88	3.5	0-261-200-079	D900-3421
BMW	733i	84	3.2	0-261-200-008	D900-3311
BMW	735i	85-87	3.4	0-261-200-059	D900-3521
BMW	735i	88	3.4	0-261-200-150	D900-3531
BMW	735i	89-91	3.4	0-261-200-179	D900-3532
BMW	750iL	88-91	5.0	0-261-200-156	D900-5031

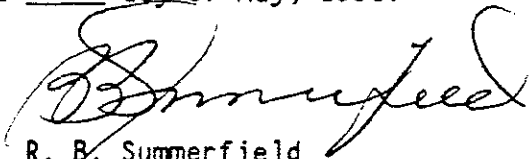
State of California
AIR RESOURCES BOARD

EVALUATION OF DINAN ENGINEERING, INC.'S PERFORMANCE CHIP FOR
EXEMPTION FROM THE PROHIBITIONS OF VEHICLE CODE SECTION 27156
IN ACCORDANCE WITH SECTION 2222, TITLE 13, OF
THE CALIFORNIA CODE OF REGULATIONS

May, 1991

May, 1991

EVALUATION OF DINAN ENGINEERING, INC.'S PERFORMANCE CHIP FOR
EXEMPTION FROM THE PROHIBITIONS IN VEHICLE CODE SECTION 27156
IN ACCORDANCE WITH SECTION 2222, TITLE 13, OF
THE CALIFORNIA CODE OF REGULATIONS

by

Mobile Source Division

State of California
AIR RESOURCES BOARD
9528 Telstar Avenue
El Monte, CA 91731-2990

(This report has been reviewed by the staff of the California Air Resources Board and approved for publication. Approval does not signify that the contents necessarily reflect the views and policies of the Air Resources Board, nor does mention of trade names or commercial products constitute endorsement or recommendation for use.)

SUMMARY

Dinan Engineering, Inc. has applied for an exemption from the prohibitions of Vehicle Code Section 27156 for their Performance Chip for installation on those model/model year BMW's listed in Appendix A. Dinan has submitted a completed application and other required information, as well as exhaust emissions test data performed at Automotive Club of Southern California Laboratory (ACSC) which shows that their Performance Chip does not have any adverse effect on the exhaust emissions of the affected vehicles. Testing performed at the Air Resources Board (ARB) confirmed the test results of ACSC.

Based on the submitted information and the results of the emissions tests performed at ACSC and the ARB, the staff concludes that the installation of Dinan's performance chip will not adversely affect exhaust emissions on the specified vehicles.

The staff recommends Dinan Engineering, Inc. be granted an exemption as requested and that Executive Order D-176-2 be issued.

CONTENTS

	<u>Page Number</u>
<u>SUMMARY</u>	i
<u>CONTENTS</u>	ii
I. <u>INTRODUCTION</u>	1
II. <u>CONCLUSION</u>	1
III. <u>RECOMMENDATIONS</u>	1
IV. <u>PERFORMANCE CHIP DESCRIPTION</u>	1
V. <u>DISCUSSION</u>	2

APPENDIX A - Model/model year BMW's compatible
with the performance chip

APPENDIX B - Performance Modifications

APPENDIX C - Performance Chip part numbers and
installation instructions

EVALUATION OF DINAN ENGINEERING, INC.'S PERFORMANCE CHIP FOR EXEMPTION FROM THE PROHIBITIONS IN VEHICLE CODE SECTION 27156 IN ACCORDANCE WITH SECTION 2222, TITLE 13, OF THE CALIFORNIA CODE OF REGULATIONS.

I. INTRODUCTION

Dinan Engineering, Inc. (Dinan) of 81 Pioneer Way, Mountain View, California 94041, has applied for an exemption from the prohibitions of Vehicle Code Section 27156 for their Performance Chip for installation on those model/model year BMW's listed in Appendix A.

Dinan has submitted a completed application and all the required information as well as data from exhaust emissions test performed at Automobile Club of Southern California Laboratory (ACSC) on a 1990 model year BMW 735i. Confirmatory test was performed on the same vehicle at the ARB.

II. CONCLUSION

Based on the submitted information and the results from exhaust emissions test performed at ACSC and confirmatory testing conducted at the ARB, the staff concludes that Dinan's performance chip will not adversely affect exhaust emissions from vehicles for which the exemption is requested.

III. RECOMMENDATIONS

The staff recommends that Dinan Engineering, Inc. be granted an exemption as requested and that Executive Order D-176-2 be issued.

IV. PERFORMANCE CHIP DESCRIPTION

The purpose of the Dinan performance chip is to improve engine performance by increasing horsepower and the electronic rev-limit. Many computer controlled vehicles are equipped with electronic control units which are programmed utilizing a removable PROM. These PROMs contain the control unit's operating systems as well as all the data used to operate the

programs. By re-programming the data prom in the Electronic Control Module's (ECM), spark timing, fuel delivery and rev-limit can be adjusted. Adjustments to these parameters are necessary to increase horsepower and the rev-limit.

The applicant states that the original equipment manufacturer's (OEM) system maintains closed loop fuel control at all times except start-up, part-throttle-high-load and full-throttle. No modifications are made by the Performance Chip to any fuel delivery operating parameters during modes of closed loop control so that the air/fuel ratio in these modes are not altered.

During open loop modes, the Performance Chip may change the ignition timing, fuel delivery and rev-limit, depending on the driving conditions. Under light-load conditions, the ignition timing is advanced to optimize fuel economy for premium fuel. Under high-load conditions, the ignition timing, fuel delivery and rev-limit are changed to optimize power output for premium fuel. Ignition timing is advanced from 0 to 15 degrees above the OEM setting. Fuel delivery is increased from 0 to 15 percent of the OEM setting or decreased from 0 to 15 percent of the OEM setting depending on the change from OEM that will be required to optimize the mixture ratio. Rev-limit is increased from 0 to 600 RPM (See Appendix B). Installation instructions, included with the chip, show the installer how to properly install the chip. Appendix C shows the installation instructions and the parts list.

V. DISCUSSION

A 1990 California-certified BMW 735i with an automatic transmission was used for emissions testing at ACSC laboratory. The test program consisted of one FTP CVS-75 (cold start) test on the test vehicle in the

modified configuration (tested against the standard). The results of the exhaust emissions test performed at ACSC are shown in Table 1.

Table 1

CVS-75 TEST RESULTS

(Automotive Club of Southern California)

	<u>HC</u>	<u>CO</u>	<u>NOx</u>
Emission standards	0.41	7.00	0.7
Performance Chip	0.32	4.16	0.19

Confirmatory testing was performed at the ARB. The results are shown in Table 2.

Table 2

CVS-75 TEST RESULTS

(Haagen-Smit Laboratory)

	<u>HC</u>	<u>CO</u>	<u>NOx</u>
Performance Chip	0.33	5.24	0.18

The CVS-75 emissions test results at ACSC and confirmatory testing at the ARB indicate that HC, CO and NOx emissions of Dinan's performance chip are well below the emission standards. This demonstrates that the installation of the Dinan performance chip on specified vehicles will not adversely affect the exhaust emissions.

Dinan submitted all the required information and fulfilled the requirements for an exemption. The test results confirmed that Dinan's Performance Chip meets the requirements for the exemption.

APPENDIX A

9. List the names, model years, engine displacements and systems that are compatible with the device, and for which exemption is requested. Specify the correct device model for each vehicle.

<u>Make</u>	<u>Model</u>	<u>Years</u>	<u>Displ</u>	<u>ECU Number</u>	<u>Dinan Engineering Performance Chip</u>
BMW	318is	90-91	1.8	0-261-200-175	D900-1833
BMW	325e	85-87	2.7	0-261-200-027	D900-2711
BMW	325i	87-88	2.5	0-261-200-153	D900-2531
BMW	325i	89-91	2.5	0-261-200-173	D900-2532
BMW	325i	89-91	2.5	0-261-200-380	D900-2533
BMW	M-3	88-91	2.3	0-261-200-071	D900-2321
BMW	525i	89-91	2.5	0-261-200-173	D900-2532
BMW	525i	89-91	2.5	0-261-200-524	D900-2534
BMW	528e	85-87	2.7	0-261-200-027	D900-2711
BMW	533i	84	3.2	0-261-200-008	D900-3311
BMW	535i	85-87	3.4	0-261-200-059	D900-3521
BMW	535i	88	3.4	0-261-200-059	D900-3522
BMW	535i	89-91	3.4	0-261-200-179	D900-3532
BMW	M-5	84-88	3.5	0-261-200-055	D900-3420
BMW	M-5	87-88	3.5	0-261-200-079	D900-3421
BMW	M-5	90-91	3.6	0-261-200-350	D900-3631
BMW	633csi	84	3.2	0-261-200-008	D900-3311
BMW	635csi	85-87	3.4	0-261-200-059	D900-3521
BMW	635csi	88	3.4	0-261-200-150	D900-3531
BMW	635csi	89	3.4	0-261-200-179	D900-3532
BMW	M-6	84-88	3.5	0-261-200-055	D900-3420
BMW	M-6	87-88	3.5	0-261-200-079	D900-3421
BMW	733i	84	3.2	0-261-200-008	D900-3311
BMW	735i	85-87	3.4	0-261-200-059	D900-3521
BMW	735i	88	3.4	0-261-200-150	D900-3531
BMW	735i	89-91	3.4	0-261-200-179	D900-3532
BMW	750iL	88-91	5.0	0-261-200-156	D900-5031

APPENDIX B

Mode or Feature	Control Mode	Modification to Ignition timing Above OEI1	Modification to Ignition timing % of OEI1	Modification to Rev-limit Above OEM
Cold-start	OPEN	NONE	NONE	NA
Cold-high-idle	OPEN	NONE	NONE	NA
Warm-start	OPEN	NONE	NONE	NA
Warm-idle	CLOSED	NONE	NONE	NA
Light-load-part-throttle	CLOSED	0-5	NONE	NA
High-load-part throttle	OPEN	0-15	+/- 15	0-600
Full-throttle	OPEN	0-15	+/- 15	0-600
Deceleration	CLOSED	NONE	NONE	NA
Deceleration-fuel-cut	NA	NONE	NONE	NA
Idle speed control	CLOSED	NONE	NONE	NA

APPENDIX C

Item C-1	Installation Instructions for	D900-2711
Item C-2	Installation Instructions for	D900-3311
Item C-3	Installation Instructions for	D900-2321 D900-3420 D900-3421 D900-3521 D900-3522
Item C-4	Installation Instructions for	D900-2531 D900-3531 D900-5031 D900-3631
Item C-5	Installation Instructions for	D900-2532 D900-3532
Item C-5A	Installation Instructions for	D900-2533
Item C-5B	Installation Instructions for	D900-2534
Item C-6	Installation Instructions for	D910-3221 D910-3222
Item C-7	Installation Instructions for	D910-2522
Item C-8	Installation Instructions for	D900-1833

**DINAN ENGINEERING PERFORMANCE CHIP INSTALLATION
MOTRONIC-1**

1985-1987 325e BOSCH ECU #0-261-200-027 or #0-261-200-021
1985-1987 528e BOSCH ECU #0-261-200-027 or #0-261-200-021

Thank you for purchasing a Dinan Engineering power chip. Many hours of research and development have gone into each program to optimize ignition and fuel delivery curves for maximum power.

Some mechanical skill is required to perform this operation. If you feel that you do not possess the required skill please arrange to have a qualified repair facility do the installation for you.

If you encounter any difficulties during this installation or if these instructions are not clear to you please call Dinan Engineering for assistance @ 415-962-9417.

TOOLS REQUIRED FOR INSTALLATION:

- Phillips screwdriver (medium)
- Phillips screwdriver (large)
- Standard screwdriver (small)
- Standard screwdriver (pocket size)
- 10mm socket on 3/8 or 1/4 drive ratchet with 6" extension

REMOVE ELECTRONIC CONTROL UNIT (ECU) FROM VEHICLE:

325e ONLY

1. Open glove box, remove pins securing limiting straps to sides of glove box and allow glove box to open all the way.
2. Remove the fasteners securing plastic glove box roof panel. Pull this panel down and allow it to rest in the glove box.
3. Remove the 10mm bolts or the Phillips screws securing the ECU. Let the ECU drop down and remove the wiring harness from it. Take ECU to the workbench.

528e ONLY

1. Open glove box, remove pins securing limiting straps to sides of glove box and allow glove box to open all the way.
2. Remove vinyl glove box roof from rear of glove box by pushing up on vinyl where it connects to rear wall of glove box. Swing vinyl roof out of glove box. DO NOT remove front end of vinyl roof as this will destroy the snaps that hold it on. Use a piece of tape to hold the vinyl to the dashboard so that it is out of your way.
3. Remove the 10mm bolts or the Phillips screws securing the ECU. Let ECU drop down and remove the wiring harness from it. Take ECU to the workbench.

ON THE WORKBENCH

4. Read Bosch part number on ECU. Should be:

0-261-200-027

0-261-200-021

If your computer does not display one of these part numbers call Dinan Engineering @ 415-562-9417.
DO NOT install the power chip!

5. Place ECU on workbench with part number label face down and remove the four screws holding the cover on. Separate case, set cover aside (you are removing the cover with no labels on it).

6. Remove the four screws and the rubber vibration isolator securing the printed circuit (PC) board to the computer chassis. Lift the PC up and flip it over as shown in figure 1.

7. See figure 1. Find the socketed chip on the upper board. This chip is elevated higher than any similar chip on the board.

8. Remove chip from socket by inserting the pocket screwdriver between the chip and the socket and prying up gently. Pry up in stages switching ends as you go until the chip is totally loose. Set stock chip aside.

9. See figure 2. Notice the small divot on one end of the power chip. Notice a similar divot on one end of the socket. The chip must be inserted so that both divots are on the same side. Some ECUs will have a 28 pin chip socket. The Dinan 24 pin chip will work in these ECUs. Plug the 24 pin chip in the 28 pin socket lining up the flat edge of the chip to the socket as in figure 2. First insert one row of pins in one side of the socket part-way. With two fingers push on the other side of the chip until the other row of pins line up with the socket and then push down on chip. Use your other hand to support the bottom side of the PC board directly below the socket while you push down on chip to make sure that it is inserted all the way. **Caution! BE CAREFUL NOT TO BEND ANY PINS.**

Visually verify that all the pins are in a socket hole and that all socket holes are filled with pins except for those that should be empty on a 28 pin socket.

10. Reassemble computer. Install ECU in vehicle.

This chip increases spark advance. This makes it necessary to run Supreme Unleaded Fuel, 91 octane or better.

The information contained on this chip is the sole property of Dinan Engineering and its reproduction is unlawful. Dinan Engineering will prosecute to the full extent of the law

***Smog Legal* in California under; ARB E.O. No. D-XXX**

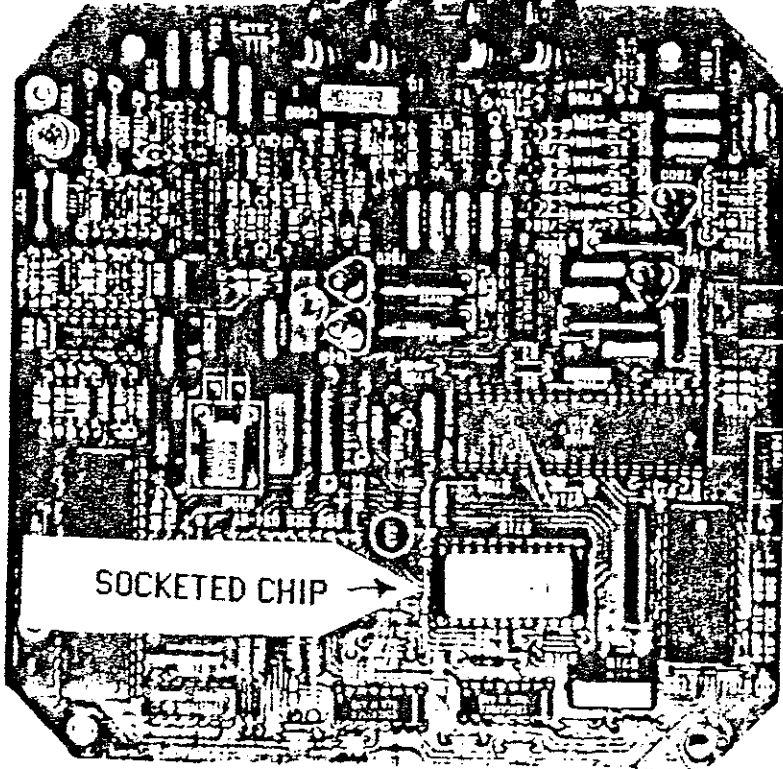
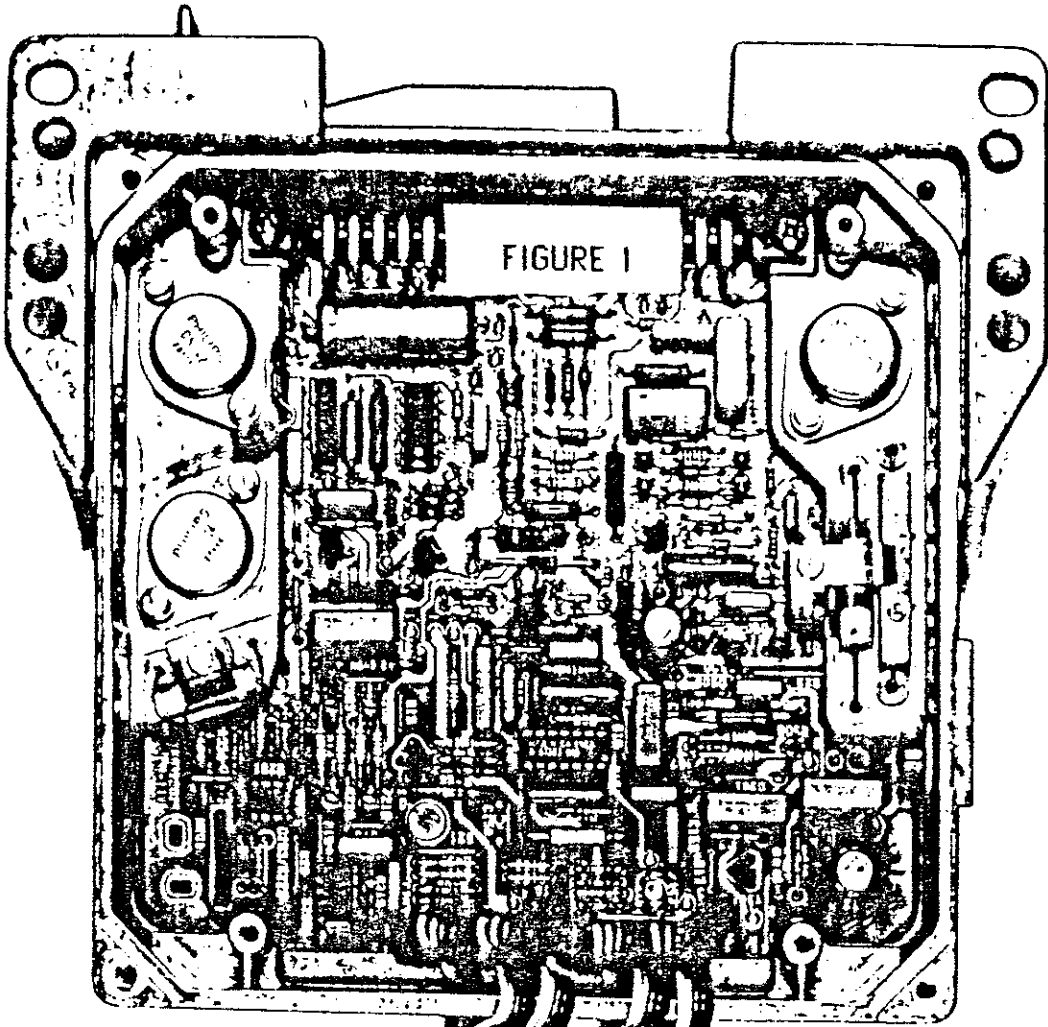
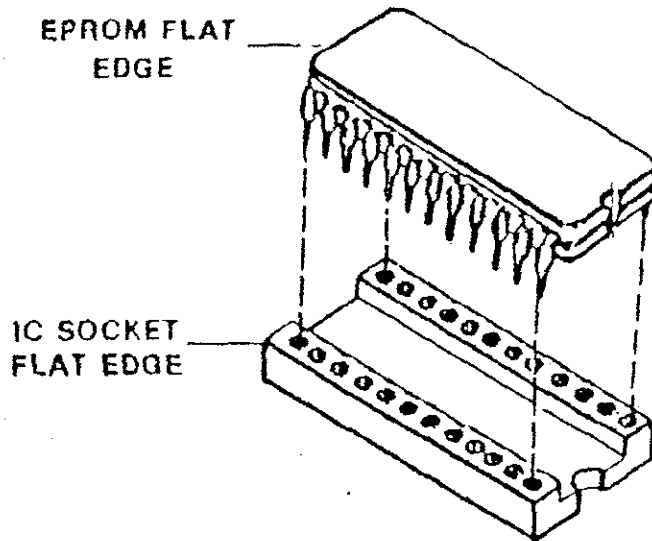
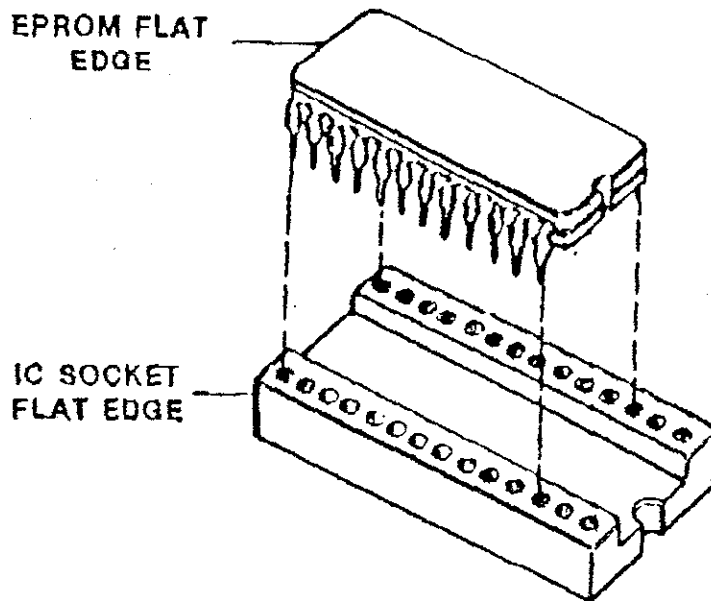

FIGURE 2

- The EPROM is correctly installed when the EPROM flat edge aligns with the IC socket flat edge.



- Some control units will have a 28 pin IC socket. When installing the 24 pin updated EPROM in a 28 pin socket, the EPROM flat edge must align with the IC flat edge. If this important point is not followed, the control unit will not operate and EPROM damage may result.



DINAN ENGINEERING PERFORMANCE CHIP INSTALLATION MOTRONIC-1

1984 533i, 633i, 733i BOSCH ECU *0-261-200-008

Thank you for purchasing a Dinan Engineering power chip. Many hours of research and development have gone into each program to optimize ignition and fuel delivery curves for maximum power.

Some mechanical skill is required to perform this operation. If you feel that you do not possess the required skill please arrange to have a qualified repair facility do the installation for you.

If you encounter any difficulties during this installation or if these instructions are not clear to you please call Dinan Engineering for assistance @ 415-962-9417.

TOOLS REQUIRED FOR INSTALLATION:

- Phillips screwdriver (medium)
- Phillips screwdriver (large)
- Standard screwdriver (small)
- Standard screwdriver (pocket size)
- 10mm socket on 3/8 or 1/4 drive ratchet with 6" extension

REMOVE ELECTRONIC CONTROL UNIT (ECU) FROM VEHICLE:

ALL CARS EXCEPT 733I

1. Open glove box, remove pins securing limiting straps to sides of glove box and allow glove box to open all the way.
2. **533i (cars with vinyl glove box roof) ONLY.** Remove vinyl glove box roof from rear of glove box by pushing up on vinyl where it connects to rear wall of glove box. Swing vinyl roof out of glove box. DO NOT remove front end of vinyl roof as this will destroy the snaps that hold it on. Use a piece of tape to hold the vinyl to the dashboard so that it is out of your way.
2. **633i (cars with hard plastic glove box roof) ONLY.** Remove the fasteners securing plastic glove box roof panel. Pull this panel down and allow it to rest in the glove box.
3. Remove the 10mm bolts or the Phillips screws securing the ECU. Let ECU drop down and remove the wiring harness from it. Take ECU to the workbench.

733I ONLY

1. Remove the Phillips screws securing passenger side front speaker panel. Swing panel out of the way.
2. Remove the 10mm bolts or the Phillips screws securing ECU. Let ECU drop down and pull it out of the hole that it is in. Remove the wiring harness from the ECU.
3. Take ECU to the workbench.

ON THE WORKBENCH:

4. Read Bosch part number on ECU. Should be:

0-261-200-008

If your computer does not display one of these part numbers call Dinan Engineering @ 415-962-9417.
DO NOT install the power chip!

5. Place ECU on workbench with part number label face down and remove the four screws holding the cover on. Separate case, set cover aside (you are removing the cover with no labels on it).

6. Remove the four screws and the rubber vibration isolator securing the printed circuit (PC) board to the computer chassis. Lift the PC up and flip it over as shown in figure 1.

7. See figure 1. Find the socketed chip on the upper board. This chip is elevated higher than any similar chip on the board. If your computer does not have a socketed chip and is different from the computer shown in figure 1 DO NOT proceed any further! You have an early version computer which can not utilize this Dinan Performance Chip. Call Dinan Engineering @ 415-962-9417.

8. Remove chip from socket by inserting the pocket screwdriver between the chip and the socket and prying up gently. Pry up in stages switching ends as you go until the chip is totally loose. Set stock chip aside.

9. See figure 2. Notice the small divot on one end of the power chip. Notice a similar divot on one end of the socket. The chip must be inserted so that both divots are on the same side. Some ECUs will have a 28 pin chip socket. The Dinan chip will work in these ECUs. Plug the 24 pin chip into the 28 pin socket lining up the flat edge of the chip to the socket as in figure 2. First insert one row of pins in one side of the socket part-way. With two fingers push on the other side of the chip until the other row of pins line up with the socket and then push down on chip. Use your other hand to support the bottom side of the PC board directly below the socket while you push down on chip to make sure that it is inserted all the way.

Caution! BE CAREFUL NOT TO BEND ANY PINS.

Visually verify that all the pins are in a socket hole and that all socket holes are filled with pins except for those that should be empty on a 28 pin socket.

10. Reassemble computer. Install ECU in vehicle.

This chip increases spark advance. This makes it necessary to run Supreme Unleaded Fuel, 91 octane or better.

The information contained on this chip is the sole property of Dinan Engineering and its reproduction is unlawful. Dinan Engineering will prosecute to the full extent of the law.

***Smog Legal* In California under; ARB E.O. No. D-XXX**

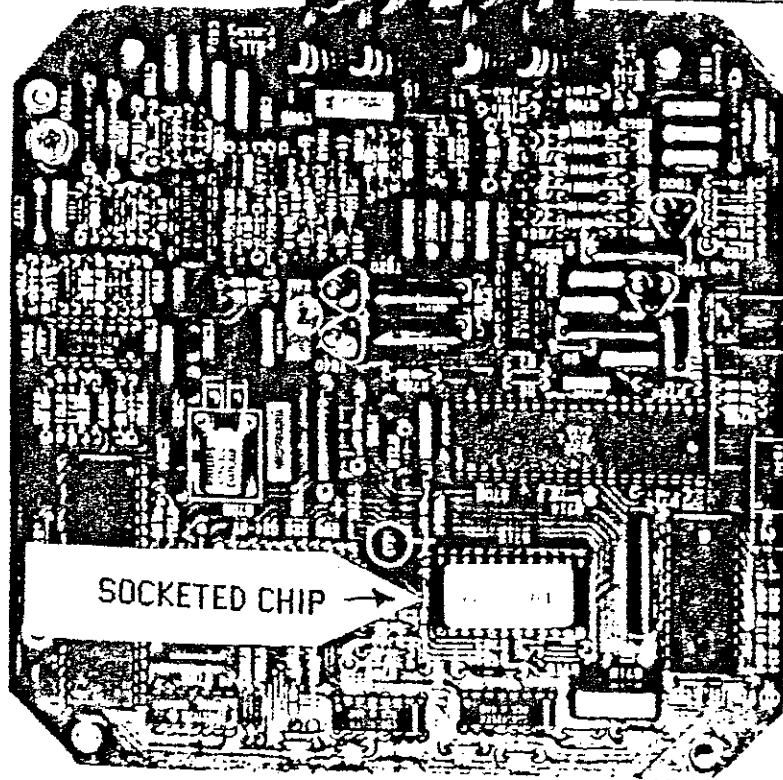
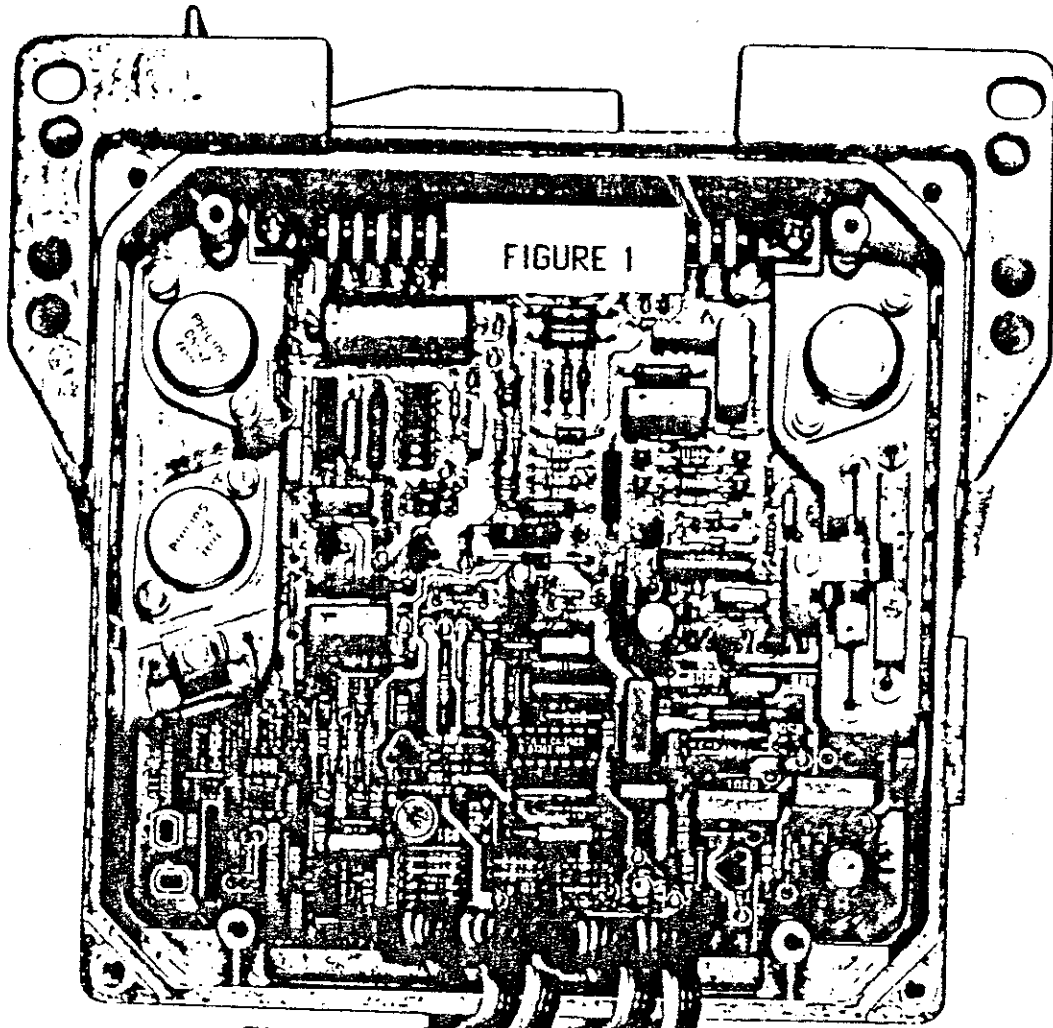
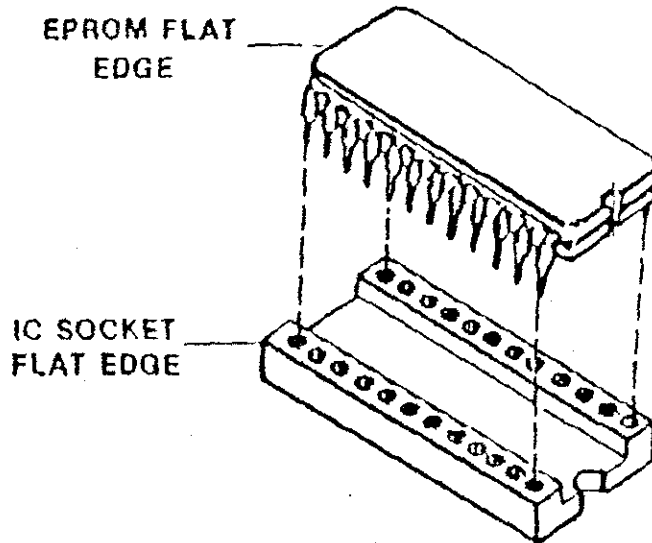
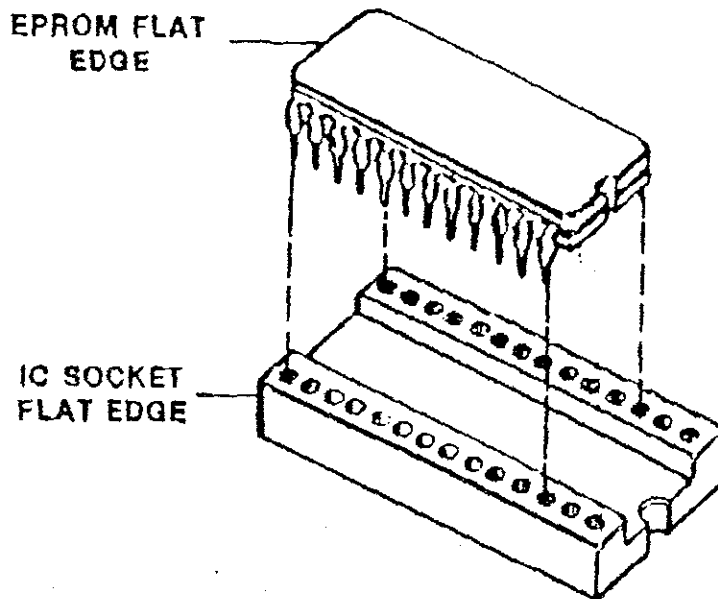

FIGURE 2

- The EPROM is correctly installed when the EPROM flat edge aligns with the IC socket flat edge.



- Some control units will have a 28 pin IC socket. When installing the 24 pin updated EPROM in a 28 pin socket, the EPROM flat edge must align with the IC flat edge. If this important point is not followed, the control unit will not operate and EPROM damage may result.



**DINAN ENGINEERING POWER CHIP INSTALLATION
FOR MOTRONIC-2**

1985-88 535i, 1985-87 635i, 735i BOSCH ECU *0-261-200-059

USA M-5, M-6 BOSCH ECU *0-261-200-079

USA M-3 BOSCH ECU *0-261-200-071

EURO M-5, M-6 BOSCH ECU *0-261-200-055

Thank you for purchasing a Dinan Engineering power chip. Many hours of research and development have gone into each program to optimize ignition and fuel delivery curves for maximum power.

Some mechanical skill is required to perform this operation. If you feel that you do not possess the required skill please arrange to have a qualified repair facility do the installation for you.

If you encounter any difficulties during this installation or if these instructions are not clear to you please call Dinan Engineering for assistance @ 415-962-9417.

TOOLS REQUIRED FOR INSTALLATION:

- Phillips screwdriver (medium)
- Standard screwdriver (small)
- Standard screwdriver (pocket size)
- 10mm socket on 3/8 or 1/4 drive ratchet with 2" extension
- Blunt nose pliers (medium)

REMOVE ELECTRONIC CONTROL UNIT (ECU) FROM VEHICLE:

ALL CARS EXCEPT 735i

1. Open glove box, remove pins securing limiting straps to sides of glove box and allow glove box to open all the way.
2. **535i, M-5 (cars with vinyl glove box roof) ONLY.** Remove vinyl glove box roof from rear of glove box by pushing up on vinyl where it connects to rear wall of glove box. Swing vinyl roof out of glove box. DO NOT remove front end of vinyl roof as this will destroy the snaps that hold it on. Use a piece of tape to hold the vinyl to the dashboard so that it is out of your way.
2. **635i, M-6, M-3 (cars with hard plastic glove box roof) ONLY.** Remove the fasteners securing plastic glove box roof panel. Pull this panel down and allow it to rest in the glove box.
3. Remove the 10mm bolts or the Phillips screws securing the ECU. Let ECU drop down and remove the wiring harness from it. Take ECU to the workbench.

735i ONLY

1. Remove the Phillips screws securing passenger side front speaker panel. Swing panel out of the way.
2. Remove the 10mm bolts or the Phillips screws securing ECU. Let ECU drop down and pull it out of the hole that it is in. Remove the wiring harness from the ECU.
3. Take ECU to the workbench

ON THE WORKBENCH.

4. Read Bosch part number on ECU. Should be:

0-261-200-059 or
0-261-200-079 or
0-261-200-071 or
0-261-200-055

If your computer does not display one of these part numbers call Dinan Engineering @ 415-962-9417.
DO NOT install the power chip!

5. See figure 1. Place ECU on workbench with part number label face down and using the pocket screwdriver pry the ten lock tabs that hold the unit together up slightly. Just enough to get the small screwdriver under the tabs and finish prying the tabs straight up. Separate case, set cover aside.

6. See figure 2 and figure 3. Hold ECU with metal side down and the plug end facing away. Grip mounting tabs with both hands and push up on upper printed circuit (PC) board where the two plastic pedestals connect to the PC board. The object here is to separate the pedestal snap connections. **Caution! DO NOT PUSH UP ON CORNERS OF PC BOARD OR BOARD WILL FLEX AND BREAK!**

7. Raise rear portion of board which was just unsnapped and slide board away from plug, until the board disengages from the plug housing. Flip over upper PC board so that both PC boards are face up.

8. See figure 4. Find socketed chip on the upper board. This chip can be identified by a sticker with a series of numbers printed on it and that it is elevated higher than any similar chip on the board.

9. Remove chip from socket by inserting the pocket screwdriver between the chip and the socket and prying up gently. Pry up in stages switching ends as you go until the chip is totally loose. Set stock chip aside.

10. See figure 5. Notice the small divot on one end of the power chip. Notice a similar divot on one end of the socket. The chip must be inserted so that both divots are on the same side. First insert one row of pins in one side of the socket part-way. With two fingers push on the other side of the chip until the other row of pins line up with the socket and then push down on chip. Use your other hand to support the bottom side of the PC board directly below the socket while you push down on chip to make sure that it is inserted all the way. **Caution! BE CAREFUL NOT TO BEND ANY PINS.**
Visually verify that all the pins are in a socket hole and that all socket holes are filled with pins.

11. Reassemble PC boards. Reinstall cover on ECU making sure to insert the white plastic sheet first. Use pliers to bend cover lock tabs back into place. Install ECU in vehicle.

This chip increases spark advance. This makes it necessary to run Supreme Unleaded Fuel, 91 octane or better.

The information contained on this chip is the sole property of Dinan Engineering and its reproduction is unlawful. Dinan Engineering will prosecute to the full extent of the law.

"Smog Legal" in California under; ARB E.O. No. D-XXX

FIGURE 1

BEND UP LOCK TABS AS SHOWN

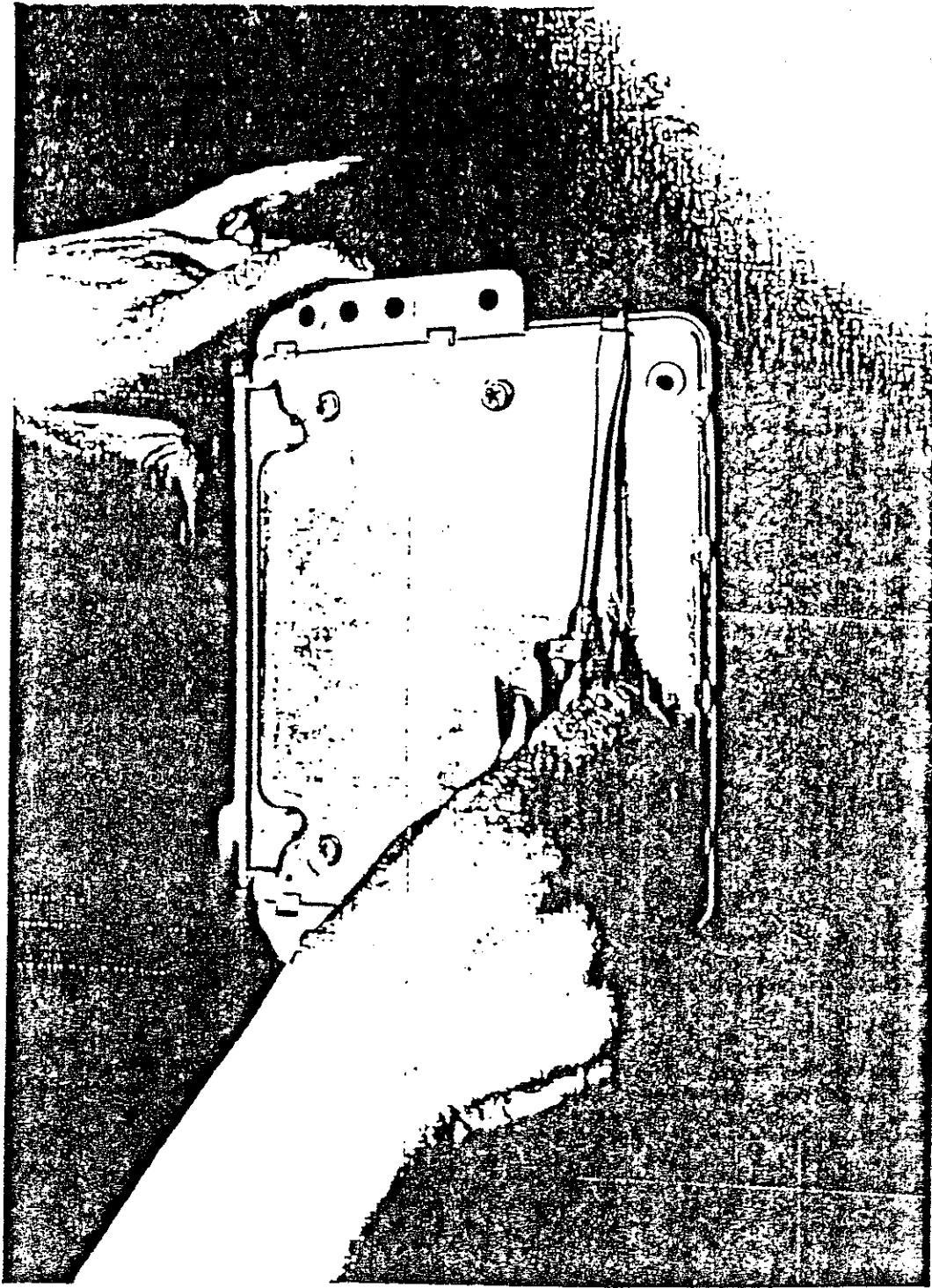

FIGURE

GRIP MOUNTING TABS AND PUSH UP ON UPPER PC BOARD.
PUSH UP WHERE PLASTIC PEDESTALS ARE, NOT ON THE CORNERS.

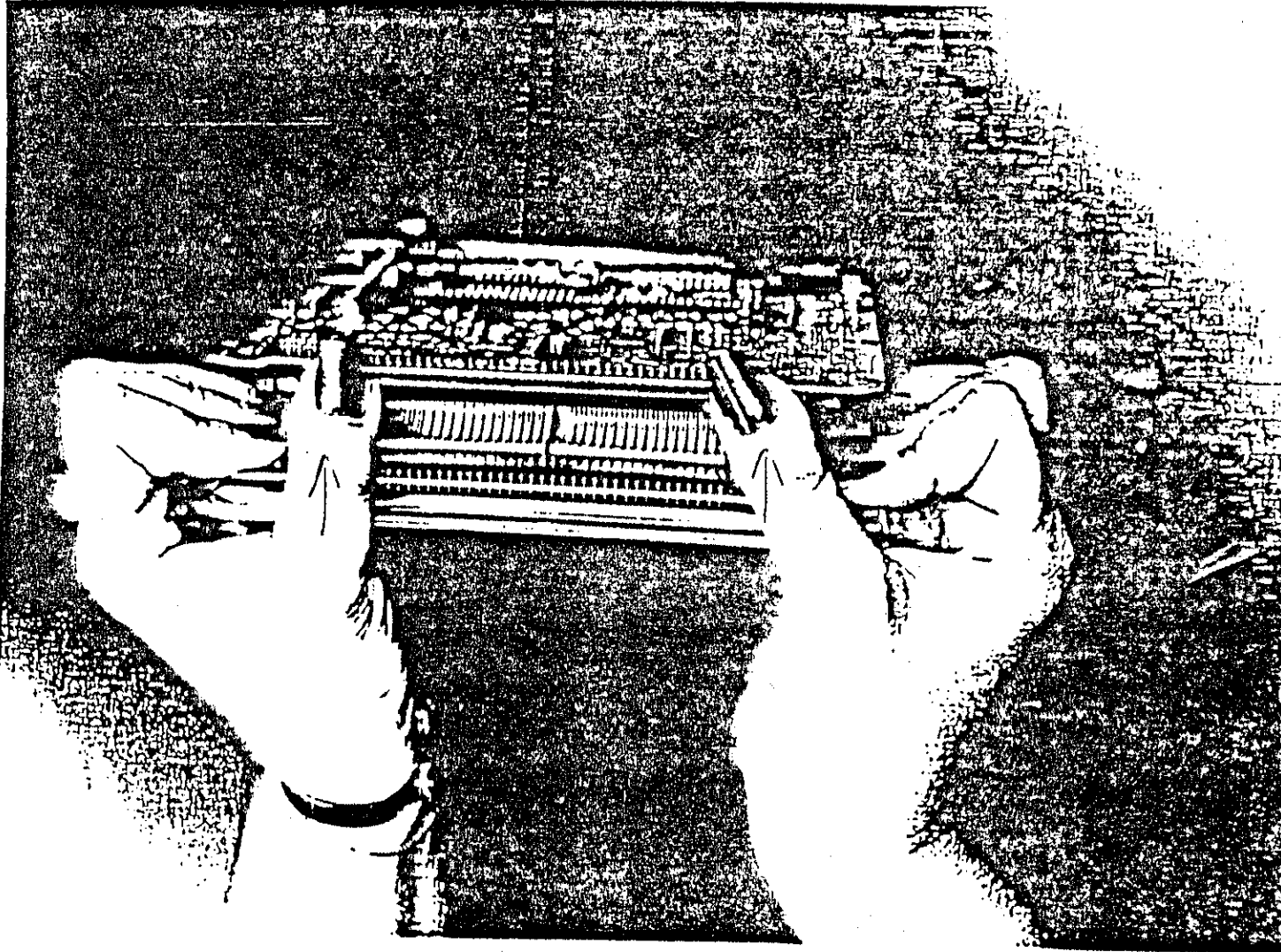
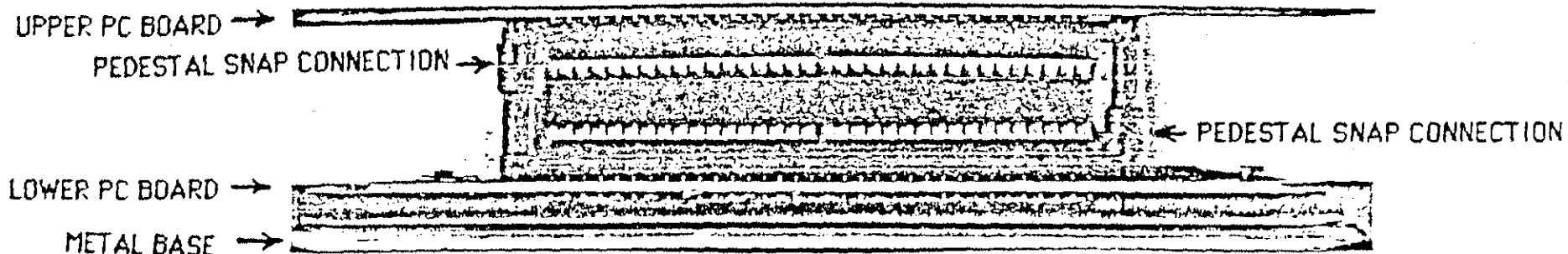
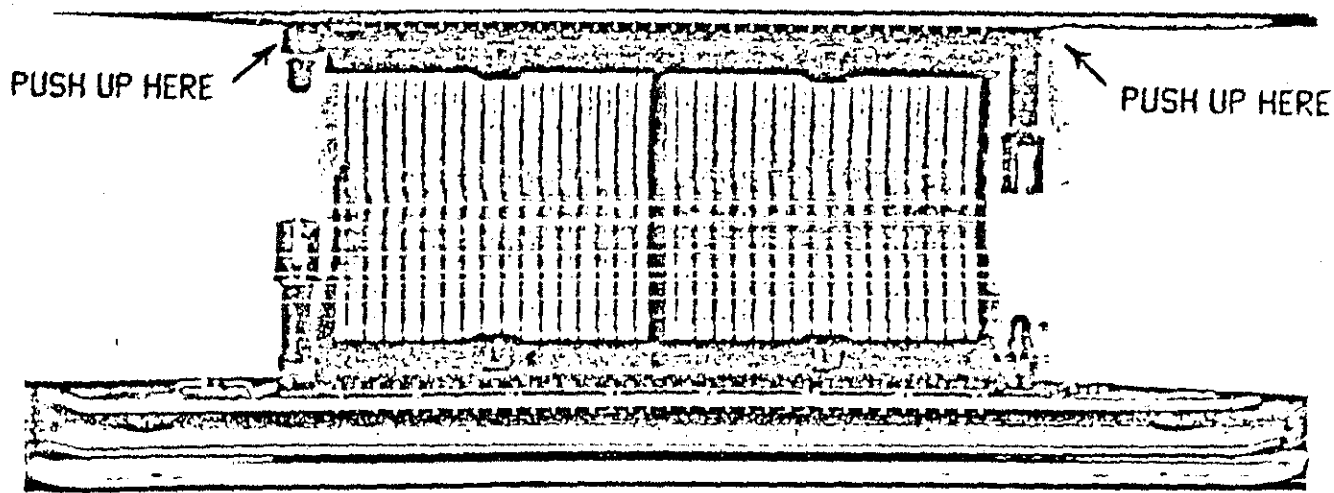

FIGURE 3



PEDESTAL SNAP CONNECTIONS CLOSED



PEDESTAL SNAP CONNECTIONS OPEN

FIGUR

CHIP LOCATION ON BOARD

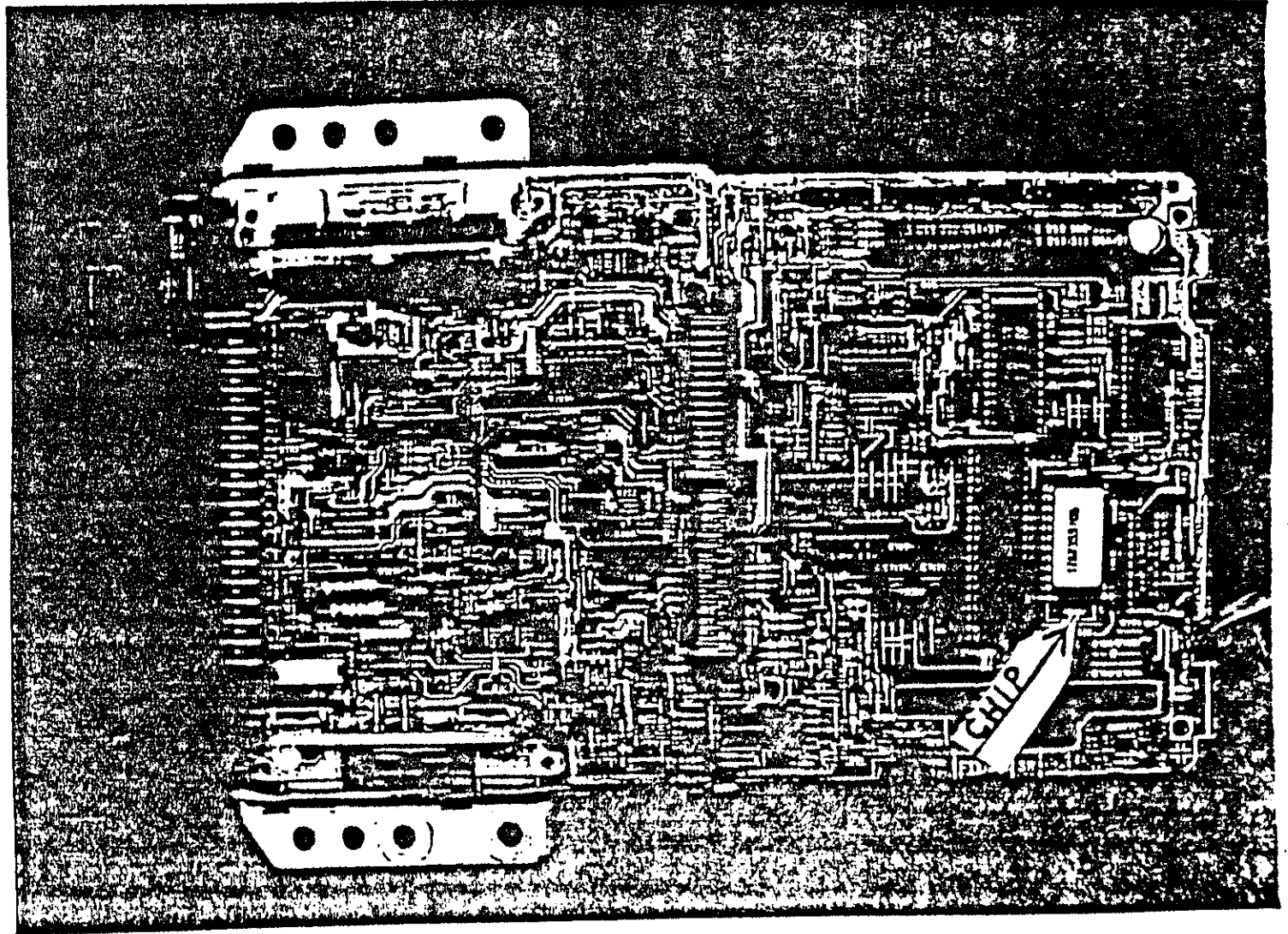

FIGURE

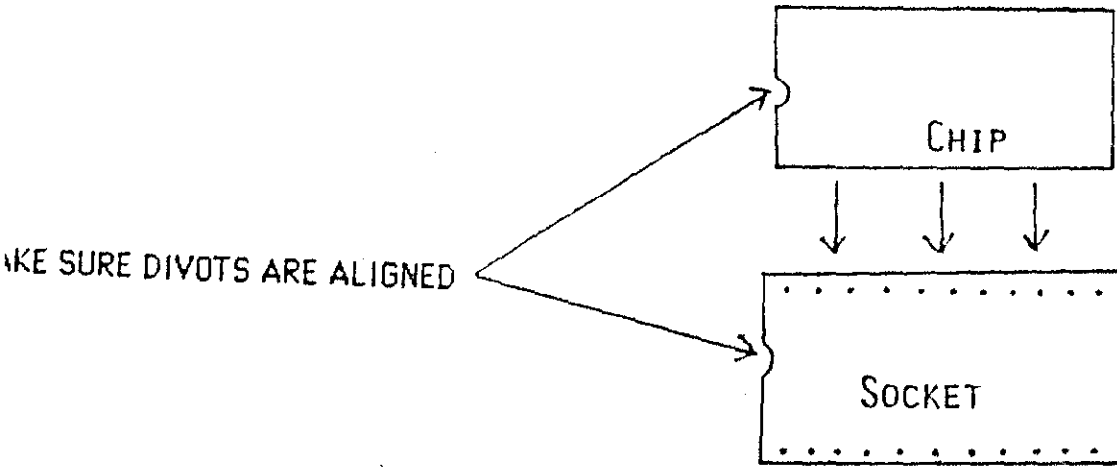

**DINAN ENGINEERING PERFORMANCE CHIP INSTALLATION
MOTRONIC-3 Version 1**

1988 635i, 735i BOSCH ECU #0-261-200-150

1988-1991 750iL BOSCH ECU #0-261-200-156

1987-1988 325i BOSCH ECU #0-261-200-153

1991 M5 BOSCH ECU #0-261-200-350

Thank you for purchasing a Dinan Engineering power chip. Many hours of research and development have gone into each program to optimize ignition and fuel delivery curves for maximum power.

Some mechanical skill is required to perform this operation. If you feel that you do not possess the required skill please arrange to have a qualified repair facility do the installation for you.

If you encounter any difficulties during this installation or if these instructions are not clear to you please call Dinan Engineering for assistance @ 415-962-9417.

TOOLS REQUIRED FOR INSTALLATION:

- Phillips screwdriver (medium)
- Phillips screwdriver (large)
- Standard screwdriver (small)
- Standard screwdriver (pocket size)
- 10mm socket on 3/8 or 1/4 drive ratchet with 6" extension
- Blunt nose pliers (medium)

REMOVE ELECTRONIC CONTROL UNIT (ECU) FROM VEHICLE:

325i, 635i ONLY

1. Open glove box, remove pins securing limiting straps to sides of glove box and allow glove box to open all the way.
2. Remove the fasteners securing plastic glove box roof panel. Pull this panel down and allow it to rest in the glove box.
3. Remove the 10mm bolts or the Phillips screws securing the ECU. Let the ECU drop down and remove the wiring harness from it. Take ECU to the workbench.

M5, 735i, 750i ONLY

1. See figure 1. Open hood, loosen four large Phillips screws securing black plastic cover located on passenger side of engine bay between strut tower and firewall. Remove cover, set aside.

M5, 735i ONLY

2. See figure 2. Disconnect wiring harness from Motronic ECU. Remove the 10mm nuts securing ECU to chassis.
3. Pull ECU straight up. Take ECU to the workbench.

750i ONLY

2. See figure 3. Disconnect wiring harness from both Motronic ECUs. Remove both black plastic wire protectors from ECU mounting tabs by pulling straight up. Remove the 10mm nuts securing ECUs to chassis.

3. Pull ECUs straight up. Take ECUs to the workbench. Perform steps 4 thru 12 on both ECUs.

ON THE WORKBENCH:

4. Read Bosch part number on ECU. Should be:

0-261-200-150 or

0-261-200-153 or

0-261-200-156 or

0-261-200-350

If your computer does not display one of these part numbers call Dinan Engineering @ 415-962-9417. DO NOT install the power chip!

5. See figure 4. Place ECU on workbench with part number label face down and using the pocket screwdriver pry the ten lock tabs that hold the unit together up slightly. Just enough to get the small screwdriver under the tabs and finish prying the tabs straight up. Separate case, set cover aside. Check to make sure your ECU has two printed circuit (PC) boards. If you have a single PC board ECU you have a newer design ECU and this chip will not work. Call Dinan Engineering @ 415-962-9417.

6. See figure 5 and figure 6. Hold ECU with metal side down and the plug end facing away. Grip mounting tabs with both hands and push up on upper printed circuit (PC) board where the two plastic pedestals connect to the PC board. The object here is to separate the pedestal snap connections. **Caution! DO NOT PUSH UP ON CORNERS OF PC BOARD OR BOARD WILL FLEX AND BREAK!**

7. This is the most difficult step! See figure 7 to understand the goal of this step, See figure 8 to understand how the latches are arranged. Hold ECU with metal side down and plug end facing you. With one hand apply upward pressure on upper PC board, as in step 6. At the same time, with your other hand, use the pocket screwdriver to release the plastic latches located inside the plug housing at both ends of the top row of pins (see fig.8). To release these latches insert the pocket screwdriver in the gap between the latch and the plug housing and rotate. The upward pressure on the upper PC board should keep the latches from relatching when the screwdriver is removed. While maintaining this position insert the small screwdriver between the plug housing and the plastic that the top row of pins are molded into and rotate, then pull the upper PC board away from the plug housing. DO NOT pry against any of the pins as they may become damaged. Pull back on upper PC board until the pins clear the plug housing and then flip over the upper PC board so that both PC boards are face up as in figure 7.

8. See figure 7. Find the socketed chip on the upper board. This chip can be identified by the black plastic "H" shaped retaining clip locking it into the socket and that it is elevated higher than any similar chip on the board.

9. See figure 9. Remove the "H" shaped retaining clip by inserting the pocket screwdriver into one of the small slots in the retaining clip and prying towards the other slot. The retaining clip will pop up on the side the screwdriver is inserted in, use a finger to hold that side up while you insert the screwdriver in the other slot and release the other side. Lift retaining clip off of the chip and set aside.

10. Remove chip from socket by inserting the pocket screwdriver between the chip and the socket and prying up gently. Pry up in stages switching ends as you go until the chip is totally loose. Set stock chip aside.

11. See figure 10. Notice the small divot on one end of the power chip. Notice a similar divot on one end of the socket. The chip must be inserted so that both divots are on the same side. First insert one row of pins in one side of the socket part-way. With two fingers push on the other side of the chip until the other row of pins line up with the socket and then push down on chip. Use your other hand to support the bottom side of the PC board directly below the socket while you push down on chip to make sure that it is inserted all the way. **Caution! BE CAREFUL NOT TO BEND ANY PINS.**

Visually verify that all the pins are in a socket hole and that all socket holes are filled with pins.

12. Reinstall retaining clip. Reassemble PC boards making sure that upper PC board is pushed into the plug housing all the way and that the latches are fully engaged. Reinstall cover on ECU making sure to insert the white plastic sheet first. Use pliers to bend cover lock tabs back into place. Install ECU in vehicle.

This chip increases spark advance. This makes it necessary to run Supreme Unleaded Fuel, 91 octane or better.

The information contained on this chip is the sole property of Dinan Engineering and its reproduction is unlawful. Dinan Engineering will prosecute to the full extent of the law.

"Smog Legal" in California under; CARB E.O. No. D-XXX

M5, 7351 and 7501 ONLY

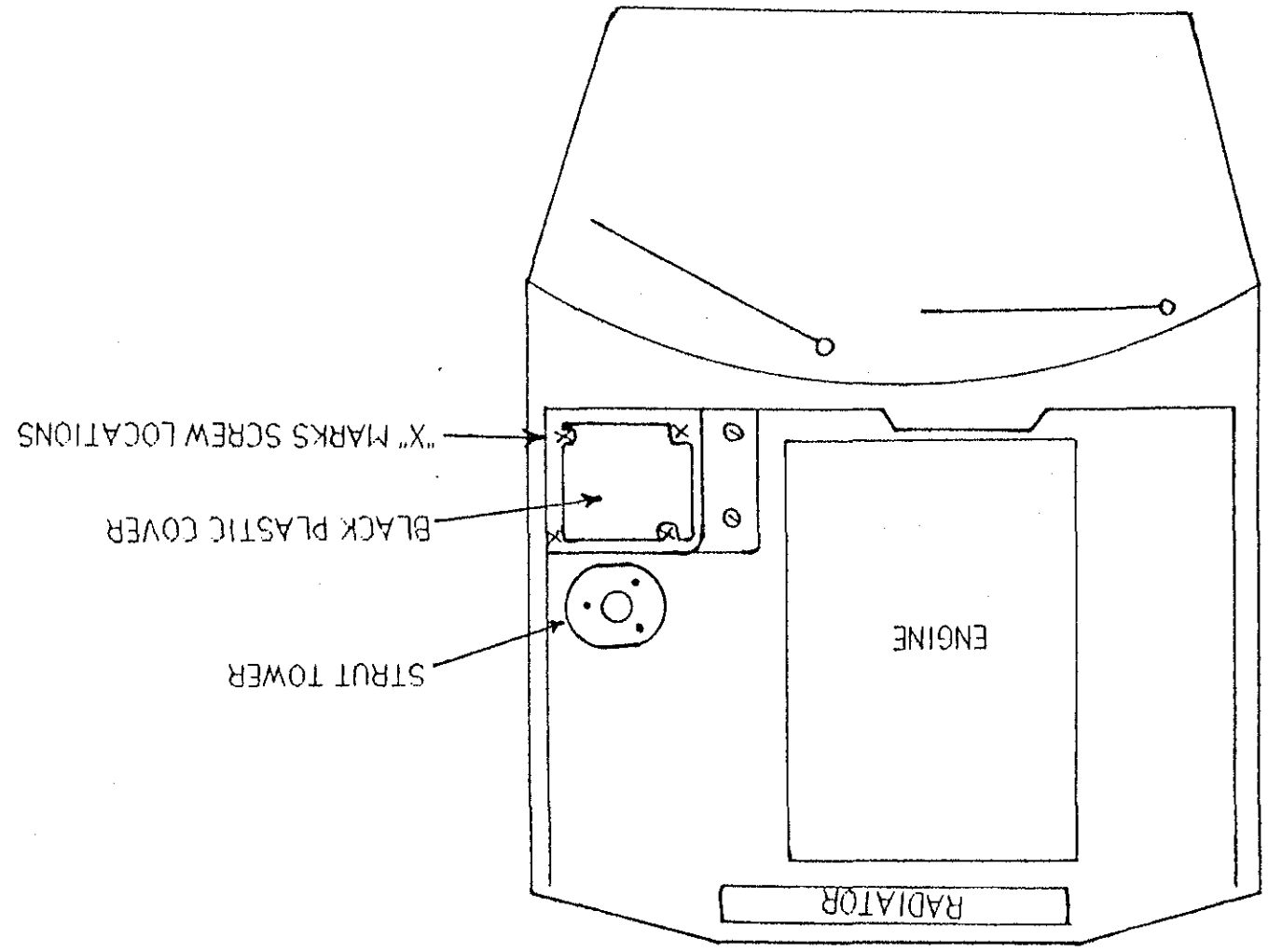

FRONT

FIGURE 1

BLACK PLASTIC WIRE PROTECTOR

MOTRONIC ECU #1

THROTTLE BODY ECU

MOTRONIC ECU #2

ABS ECU

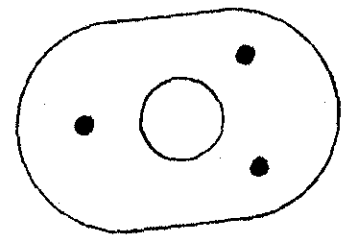
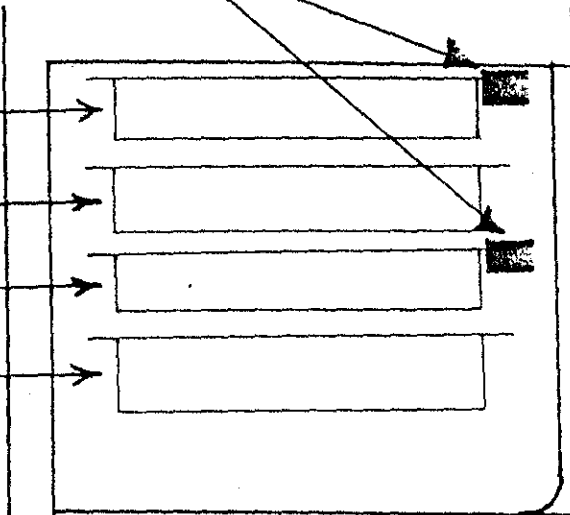

750i ONLY

FIGURE 1

FRONT

BLACK PLASTIC WIRE PROTECTOR

MOTRONIC ECU

CRUISE CONTROL ECU

ABS ECU

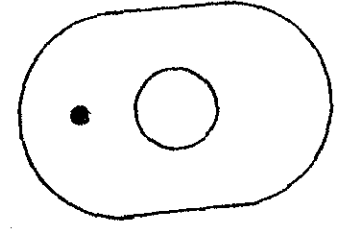
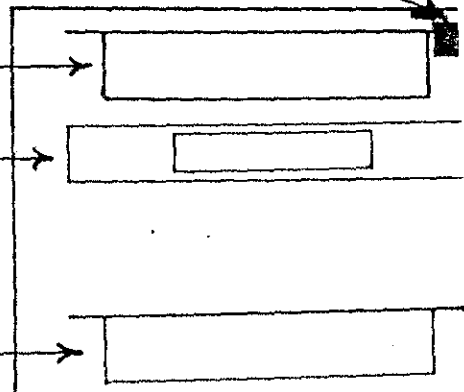

MS. 735i ONLY

FIGURE 2

FRONT

FIGURE 4

BEND UP LOCK TABS AS SHOWN

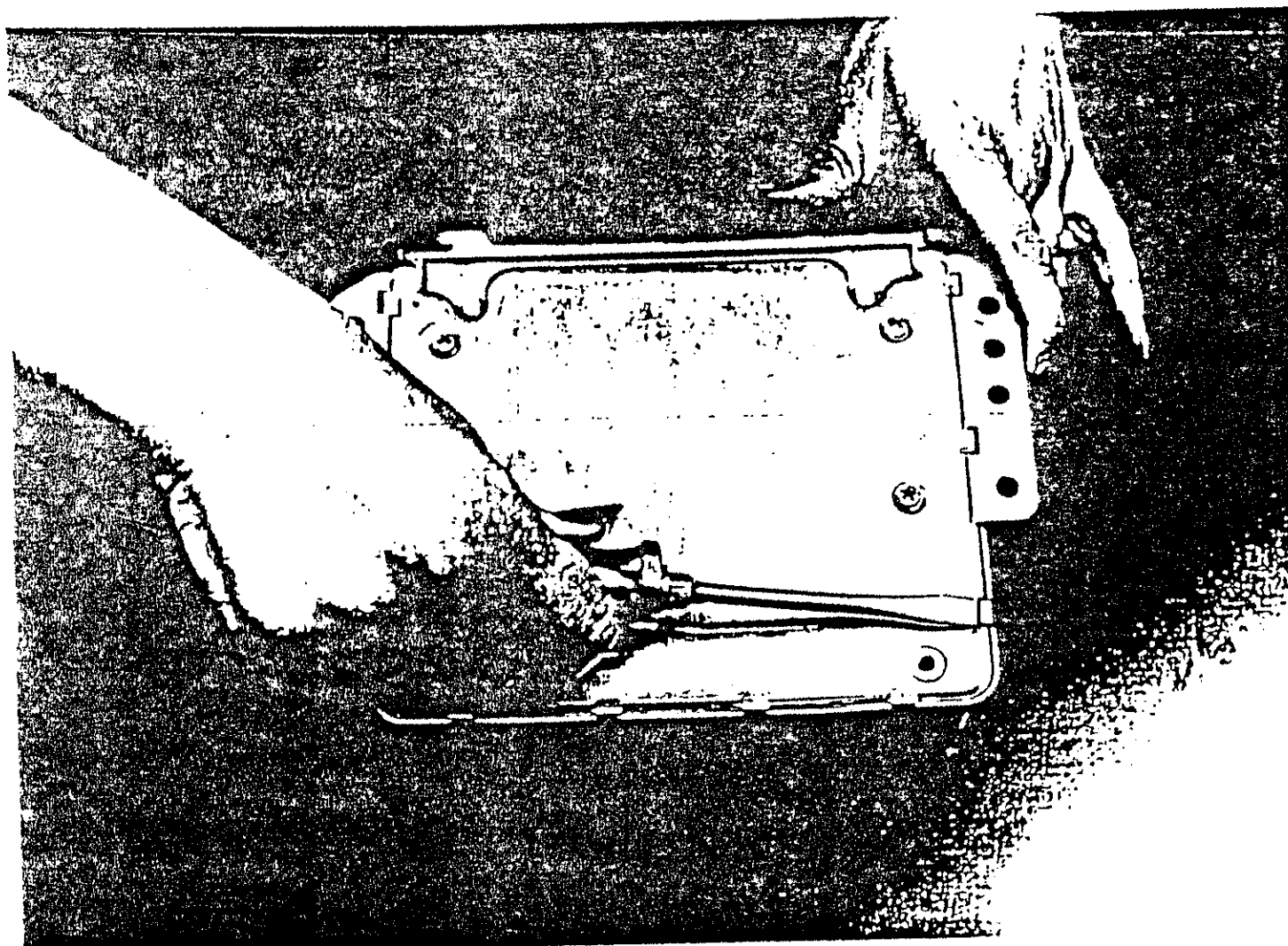

FIGURE 5

GRIP MOUNTING TABS AND PUSH UP ON UPPER PC BOARD.
PUSH UP WHERE PLASTIC PEDESTALS ARE, NOT ON THE CORNERS.

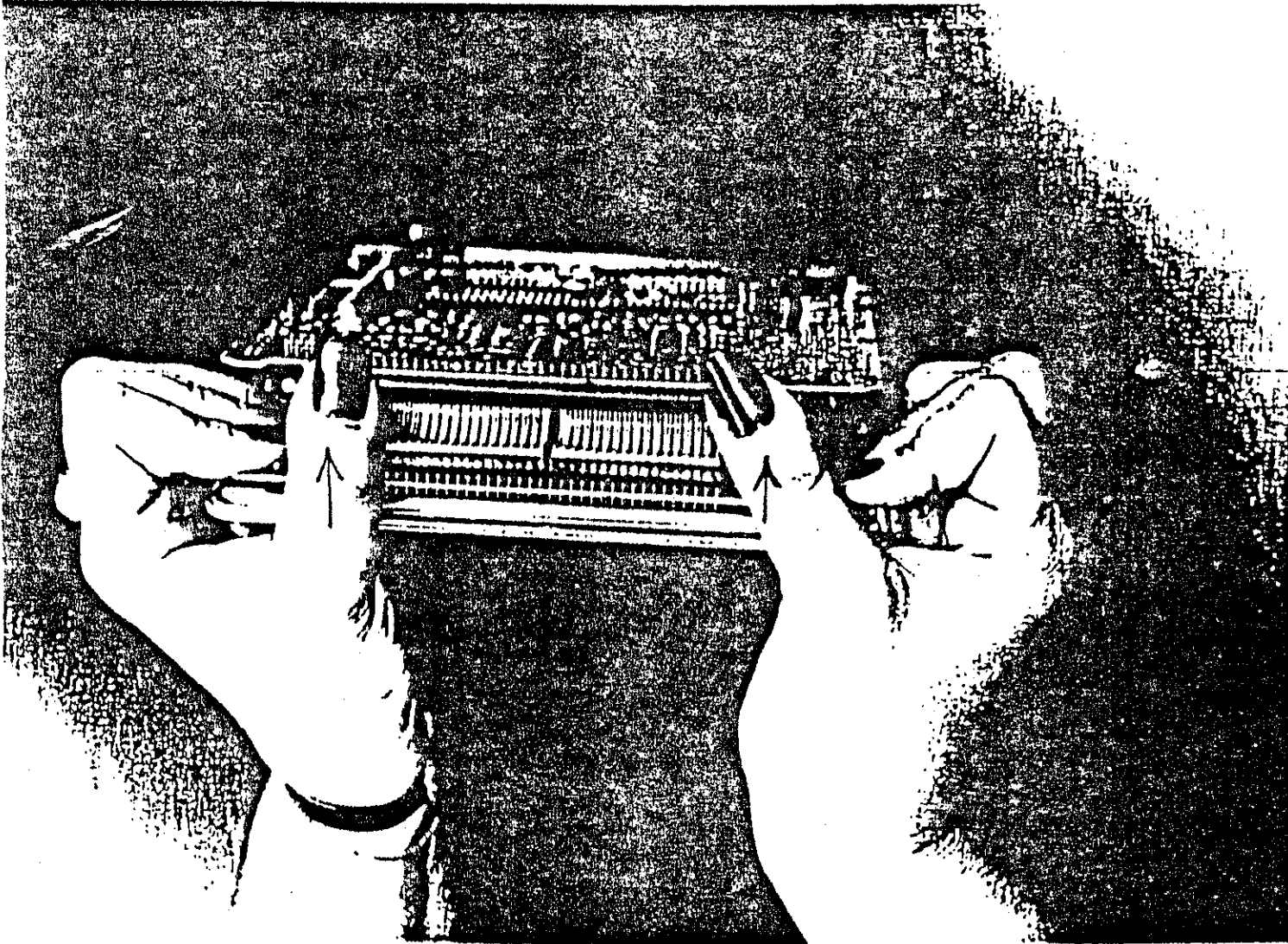
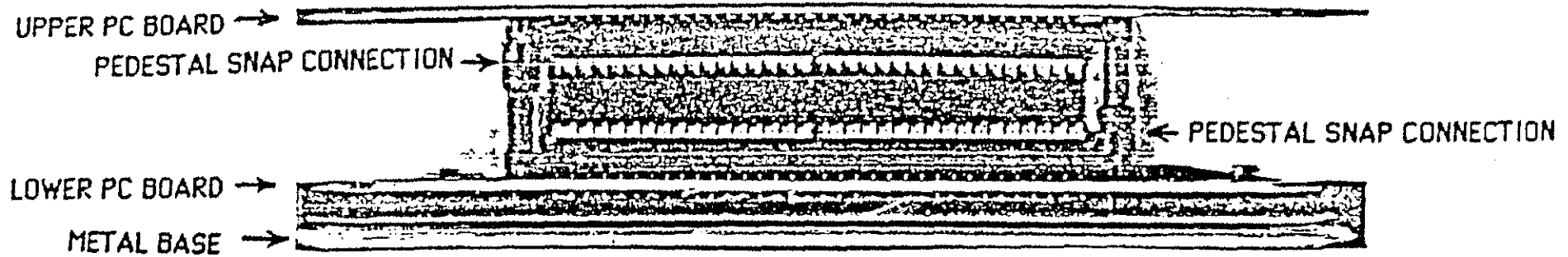
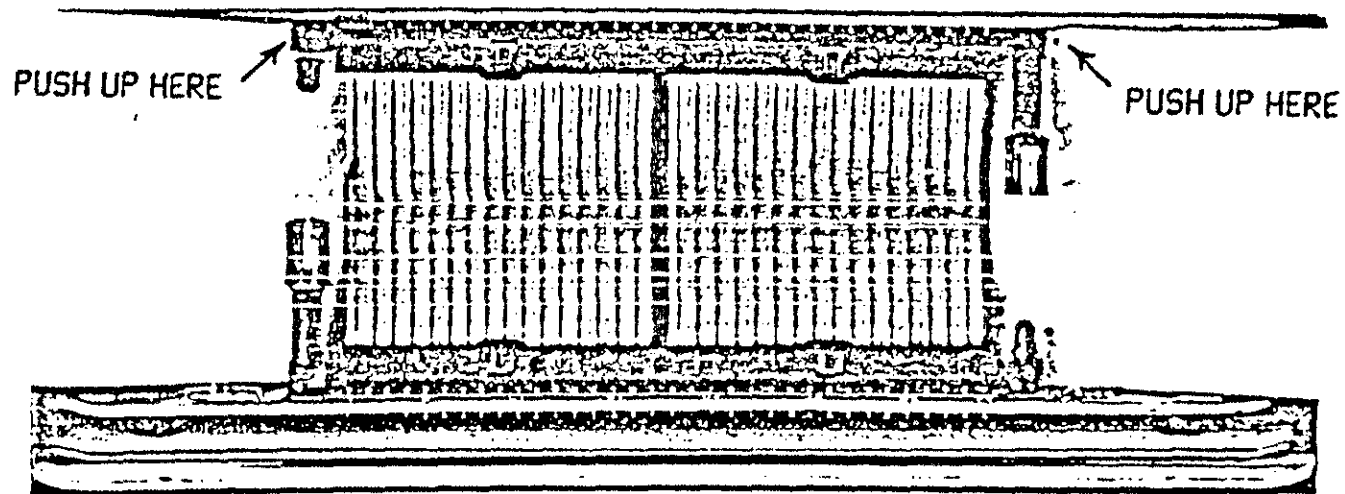

FIGURE 6



PEDESTAL SNAP CONNECTIONS CLOSED



PEDESTAL SNAP CONNECTIONS OPEN

FIGURE

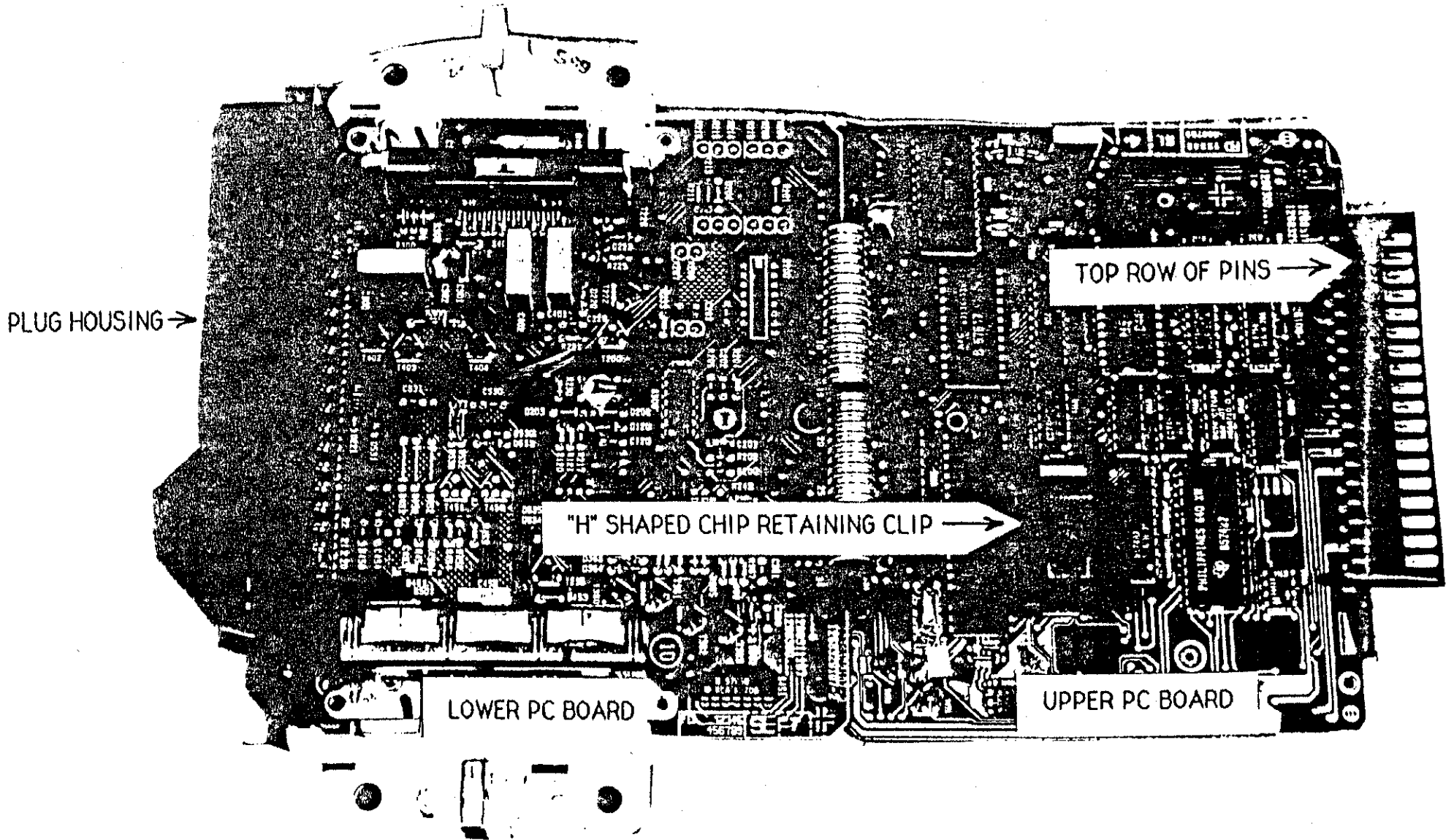

PLUG HOUSING →

TOP ROW OF PINS →

"H" SHAPED CHIP RETAINING CLIP →

LOWER PC BOARD

UPPER PC BOARD

FIGURE 8

INSERT SMALL SCREWDRIVER HERE
ROTATE AND WITH YOUR OTHER HAND
PULL BACK ON UPPER PC BOARD

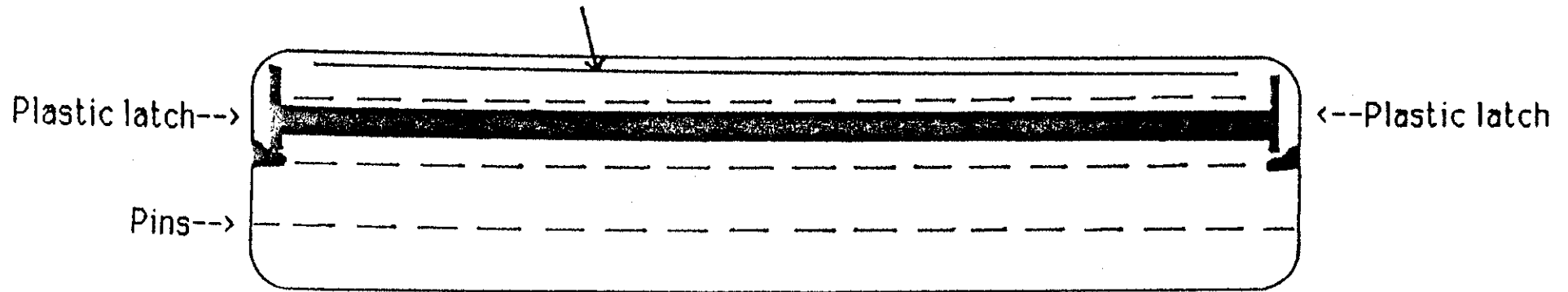

FIGURE 9

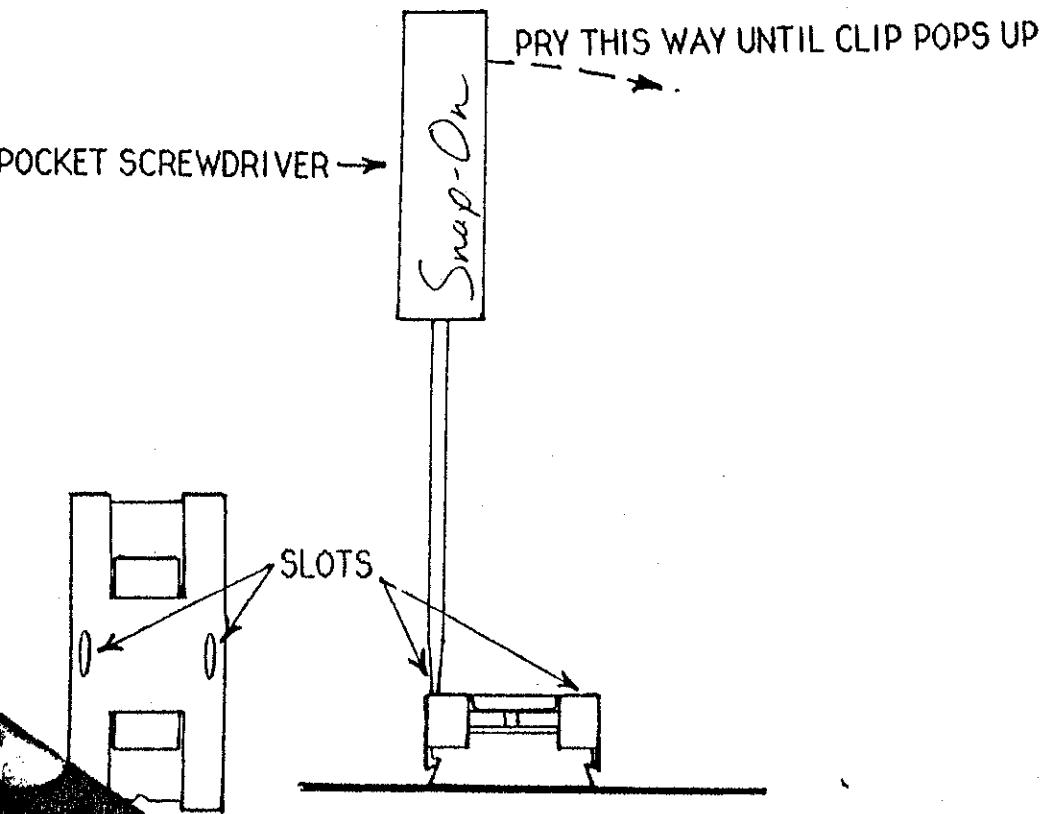
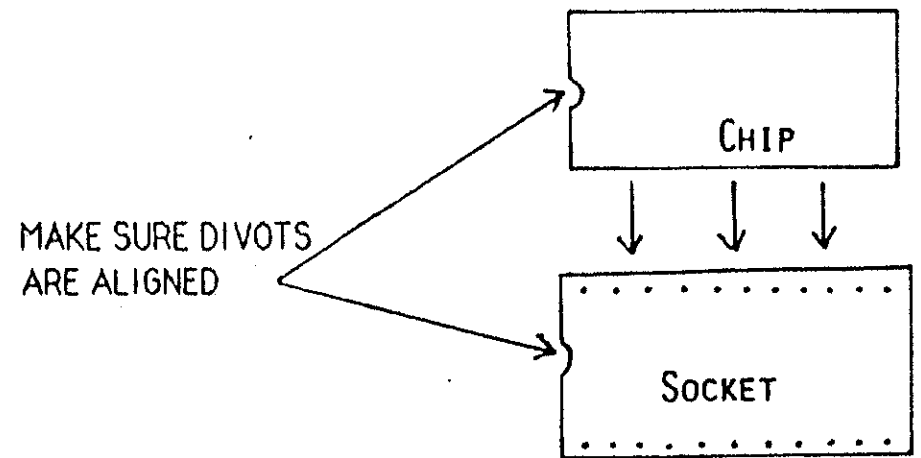

FIGURE 10



DINAN ENGINEERING POWER CHIP INSTALLATION
MOTRONIC-3 Version 2
1989-→535i, 635i, 735i BOSCH ECU #0-261-200-179
1989-1990 325i, 325ix, 525i BOSCH ECU #0-261-200-173

Thank you for purchasing a Dinan Engineering power chip. Many hours of research and development have gone into each program to optimize ignition and fuel delivery curves for maximum power.

Some mechanical skill is required to perform this operation. If you feel that you do not possess the required skill please arrange to have a qualified repair facility do the installation for you.

If you encounter any difficulties during this installation or if these instructions are not clear to you please call Dinan Engineering for assistance @ 415-962-9417.

TOOLS REQUIRED FOR INSTALLATION:

- Phillips screwdriver (medium)
- Phillips screwdriver (large)
- Standard screwdriver (small)
- Standard screwdriver (pocket size)
- 10mm socket on 3/8 or 1/4 drive ratchet with 6" extension
- Blunt nose pliers (medium)

REMOVE ELECTRONIC CONTROL UNIT (ECU) FROM VEHICLE.

325i, 635i ONLY

1. Open glove box, remove pins securing limiting straps to sides of glove box and allow glove box to open all the way.
2. Remove the fasteners securing plastic glove box roof panel. Pull this panel down and allow it to rest in the glove box.
3. Remove the 10mm bolts or the Phillips screws securing the ECU. Let the ECU drop down and remove the wiring harness from it. Take ECU to the workbench.

525i, 535i, 735i ONLY

1. See figure 1. Open hood, loosen four large Phillips screws securing black plastic cover located on passenger side of engine bay between strut tower and firewall. Remove cover, set aside.
2. See figure 2. Disconnect wiring harness from Motronic ECU. Remove black plastic wire protector from ECU mounting tab by pulling straight up. Remove the 10mm nuts securing ECU to chassis.
3. Pull ECU straight up. Take ECU to the workbench.

ON THE WORKBENCH:

4. Read Bosch part number on ECU. Should be:

0-261-200-179 or
0-261-200-173

If your computer does not display one of these part numbers call Dinan Engineering @ 415-962-9417.
DO NOT install the power chip!

5. See figure 3. Place ECU on workbench with part number label face down and using the pocket screwdriver pry the ten lock tabs that hold the unit together up slightly. Just enough to get the small screwdriver under the tabs and finish prying the tabs straight up. Separate case, set cover aside. Check to make sure your ECU has one printed circuit (PC) board. If you have a two PC board ECU you have an older design ECU and this chip will not work. Call Dinan Engineering @ 415-962-9417.

6. See figure 4. Find the socketed chip on the board. This chip can be identified by the black plastic "H" shaped retaining clip locking it into the socket and that it is elevated higher than any similar chip on the board.

7. See figure 5. Remove the "H" shaped retaining clip by inserting the pocket screwdriver into one of the small slots in the retaining clip and prying towards the other slot. The retaining clip will pop up on the side the screwdriver is inserted in, use a finger to hold that side up while you insert the screwdriver in the other slot and release the other side. Lift retaining clip off of the chip and set aside.

10. Remove chip from socket by inserting the pocket screwdriver between the chip and the socket and prying up gently. Pry up in stages switching ends as you go until the chip is totally loose. Set stock chip aside.

11. See figure 6. Notice the small divot on one end of the power chip. Notice a similar divot on one end of the socket. The chip must be inserted so that both divots are on the same side. First insert one row of pins in one side of the socket part-way. With two fingers push on the other side of the chip until the other row of pins line up with the socket and then push down on chip and make sure that it is inserted all the way. **Caution! BE CAREFUL NOT TO BEND ANY PINS.**

Visually verify that all the pins are in a socket hole and that all socket holes are filled with pins.

12. Reinstall retaining clip. Reinstall cover on ECU; use pliers to bend cover lock tabs back into place. Install ECU in vehicle.

This chip increases spark advance. This makes it necessary to run Supreme Unleaded Fuel, 91 octane or better.

The information contained on this chip is the sole property of Dinan Engineering and its reproduction is unlawful. Dinan Engineering will prosecute to the full extent of the law.

"Smog Legal" in California under; ARB E.O. No. D-XXX

FIGURE 3

BEND UP LOCK TABS AS SHOWN

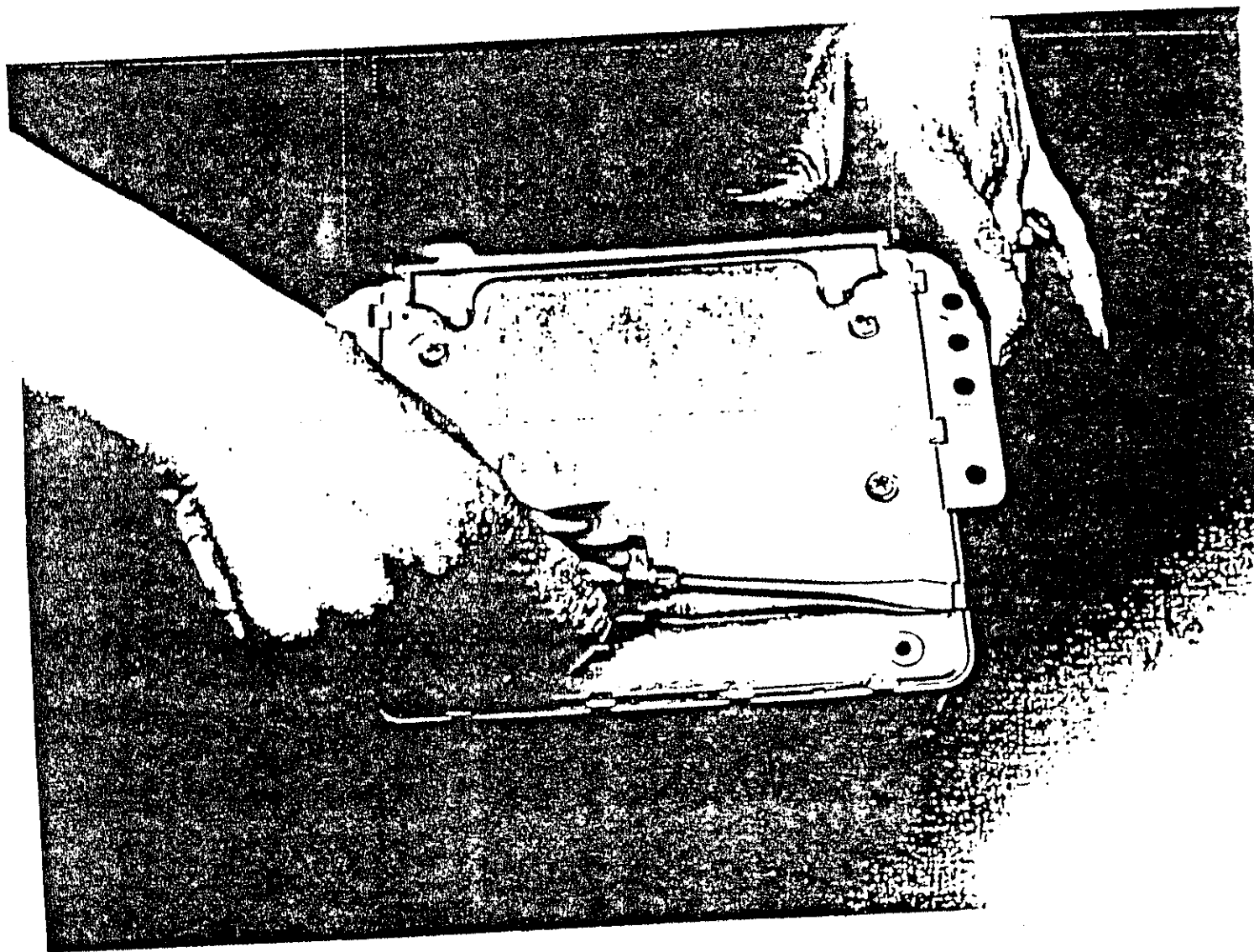

C-3A

DINAN ENGINEERING POWER CHIP INSTALLATION
MOTRONIC-3 Version 2
1989-1990 325i, 325ix BOSCH ECU #0-261-200-380

Thank you for purchasing a Dinan Engineering power chip. Many hours of research and development have gone into each program to optimize ignition and fuel delivery curves for maximum power.

Some mechanical skill is required to perform this operation. If you feel that you do not possess the required skill please arrange to have a qualified repair facility do the installation for you.

If you encounter any difficulties during this installation or if these instructions are not clear to you please call Dinan Engineering for assistance @ 415-962-9417.

TOOLS REQUIRED FOR INSTALLATION:

- Phillips screwdriver (medium)
- Phillips screwdriver (large)
- Standard screwdriver (small)
- Standard screwdriver (pocket size)
- 10mm socket on 3/8 or 1/4 drive ratchet with 6" extension
- Blunt nose pliers (medium)

REMOVE ELECTRONIC CONTROL UNIT (ECU) FROM VEHICLE:

1. Open glove box, remove pins securing limiting straps to sides of glove box and allow glove box to open all the way.
2. Remove the fasteners securing plastic glove box roof panel. Pull this panel down and allow it to rest in the glove box.
3. Remove the 10mm bolts or the Phillips screws securing the ECU. Let the ECU drop down and remove the wiring harness from it. Take ECU to the workbench.

ON THE WORKBENCH

4. Read Bosch part number on ECU. Should be:

0-261-200-380

If your computer does not display one of these part numbers call Dinan Engineering @ 415-962-9417.
DO NOT install the power chip!

5. Place ECU on workbench with part number label facing up and remove the four small screws near the plug housing. See figure 3. Place ECU on workbench with part number label face down and using the pocket screwdriver pry the ten lock tabs that hold the unit together up slightly. Just enough to get the small screwdriver under the tabs and finish prying the tabs straight up. Separate case, set cover aside. Check to make sure your ECU has one printed circuit (PC) board. If you have a two PC board ECU you have an older design ECU and this chip will not work. Call Dinan Engineering @ 415-962-9417.

6. See figure 4. Find the socketed chip on the board. This chip can be identified by the black plastic "H" shaped retaining clip locking it into the socket and that it is elevated higher than any similar chip on the board.

7. See figure 5. Remove the "H" shaped retaining clip by inserting the pocket screwdriver into one of the small slots in the retaining clip and prying towards the other slot. The retaining clip will pop up on the side the screwdriver is inserted in, use a finger to hold that side up while you insert the screwdriver in the other slot and release the other side. Lift retaining clip off of the chip and set aside.

10. Remove chip from socket by inserting the pocket screwdriver between the chip and the socket and prying up gently. Pry up in stages switching ends as you go until the chip is totally loose. Set stock chip aside.

11. See figure 6. Notice the small divot on one end of the power chip. Notice a similar divot on one end of the socket. The chip must be inserted so that both divots are on the same side. First insert one row of pins in one side of the socket part-way. With two fingers push on the other side of the chip until the other row of pins line up with the socket and then push down on chip and make sure that it is inserted all the way. **Caution! BE CAREFUL NOT TO BEND ANY PINS.**

Visually verify that all the pins are in a socket hole and that all socket holes are filled with pins.

12. Reinstall retaining clip. Reinstall cover on ECU, use pliers to bend cover lock tabs back into place. Replace the four screws removed in step 5. Install ECU in vehicle.

This chip increases spark advance. This makes it necessary to run Supreme Unleaded Fuel, 91 octane or better.

The information contained on this chip is the sole property of Dinan Engineering and its reproduction is unlawful. Dinan Engineering will prosecute to the full extent of the law.

"Smog Legal" in California under; ARB E.O. No. D-XXX

FIGURE 3

BEND UP LOCK TABS AS SHOWN

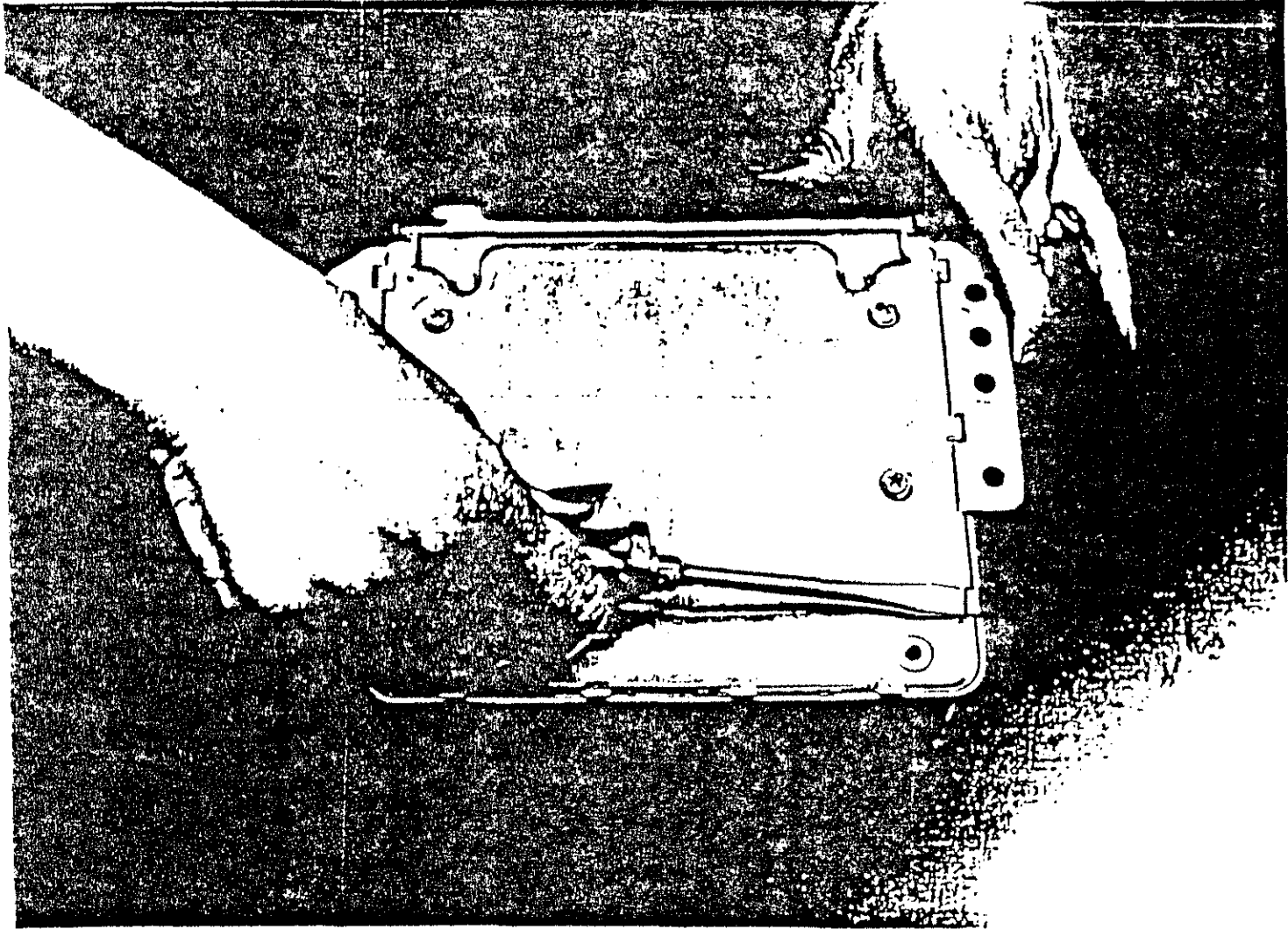

FIGURE 5

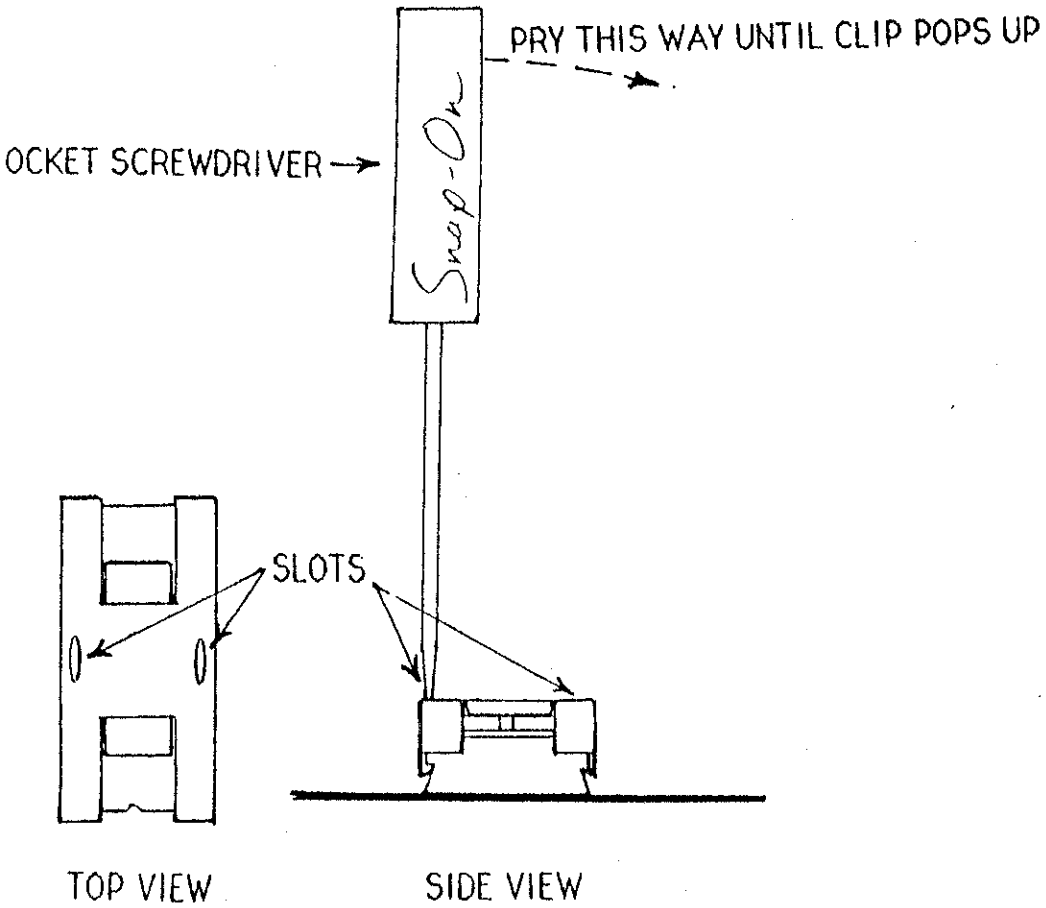
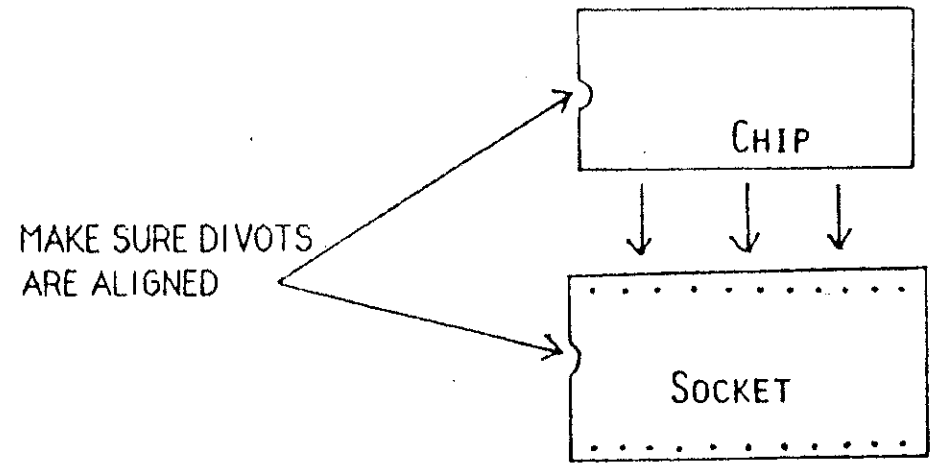

FIGURE 6



**DINAN ENGINEERING POWER CHIP INSTALLATION
MOTRONIC-3 Version 2
1990 525I BOSCH ECU #0-261-200-524**

Thank you for purchasing a Dinan Engineering power chip. Many hours of research and development have gone into each program to optimize ignition and fuel delivery curves for maximum power.

Some mechanical skill is required to perform this operation. If you feel that you do not possess the required skill please arrange to have a qualified repair facility do the installation for you.

If you encounter any difficulties during this installation or if these instructions are not clear to you please call Dinan Engineering for assistance @ 415-962-9417.

TOOLS REQUIRED FOR INSTALLATION:

- Phillips screwdriver (large)
- Standard screwdriver (small)
- Standard screwdriver (pocket size)
- 10mm socket on 3/8 or 1/4 drive ratchet with 6" extension
- Blunt nose pliers (medium)

REMOVE ELECTRONIC CONTROL UNIT (ECU) FROM VEHICLE:

1. See figure 1. Open hood, loosen four large Phillips screws securing black plastic cover located on passenger side of engine bay between strut tower and firewall. Remove cover, set aside.
2. See figure 2. Disconnect wiring harness from Motronic ECU. Remove black plastic wire protector from ECU mounting tab by pulling straight up. Remove the 10mm nuts securing ECU to chassis.
3. Pull ECU straight up. Take ECU to the workbench.

ON THE WORKBENCH:

4. Read Bosch part number on ECU. Should be:

0-262-200-524

If your computer does not display one of these part numbers call Dinan Engineering @ 415-962-9417.
DO NOT install the power chip!

5. See figure 3. Place ECU on workbench with part number label face down and using the pocket screwdriver pry the ten lock tabs that hold the unit together up slightly. Just enough to get the small screwdriver under the tabs and finish prying the tabs straight up. Separate case, set cover aside.
6. See figure 4. Find the socketed chip on the board. This chip can be identified by the black plastic "H" shaped retaining clip locking it into the socket and that it is elevated higher than any similar chip on the board.
7. See figure 5. Remove the "H" shaped retaining clip by inserting the pocket screwdriver into one of the small slots in the retaining clip and prying towards the other slot. The retaining clip will pop up on the side the screwdriver is inserted in, use a finger to hold that side up while you insert the screwdriver in the other slot and release the other side. Lift retaining clip off of the chip and set aside.
10. Remove chip from socket by inserting the pocket screwdriver between the chip and the socket and prying up gently. Pry up in stages switching ends as you go until the chip is totally loose. Set stock chip aside.
11. See figure 6. Notice the small divot on one end of the power chip. Notice a similar divot on one end of the socket. The chip must be inserted so that both divots are on the same side. First insert one row of pins in one side of the socket part-way. With two fingers push on the other side of the chip until the other row of pins line up with the socket and then push down on chip and make sure that it is inserted all the way. **Caution! BE CAREFUL NOT TO BEND ANY PINS.** Visually verify that all the pins are in a socket hole and that all socket holes are filled with pins.
12. Reinstall retaining clip. Reinstall cover on ECU, use pliers to bend cover lock tabs back into place. Install ECU in vehicle.

This chip increases spark advance. This makes it necessary to run Supreme Unleaded Fuel, 91 octane or better.

The information contained on this chip is the sole property of Dinan Engineering and its reproduction is unlawful. Dinan Engineering will prosecute to the full extent of the law.

"Smog Legal" in California under; ARB E.O. No. D-XXX

525i, 535i and 735i ONLY

FIGURE 2

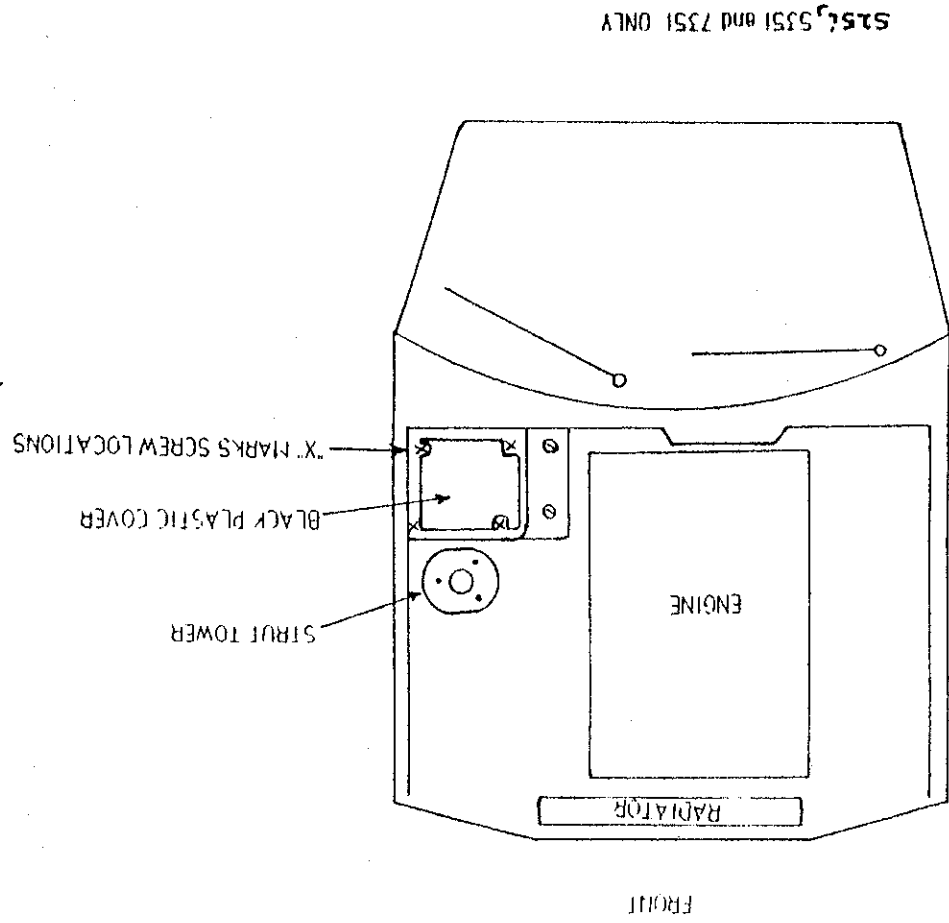
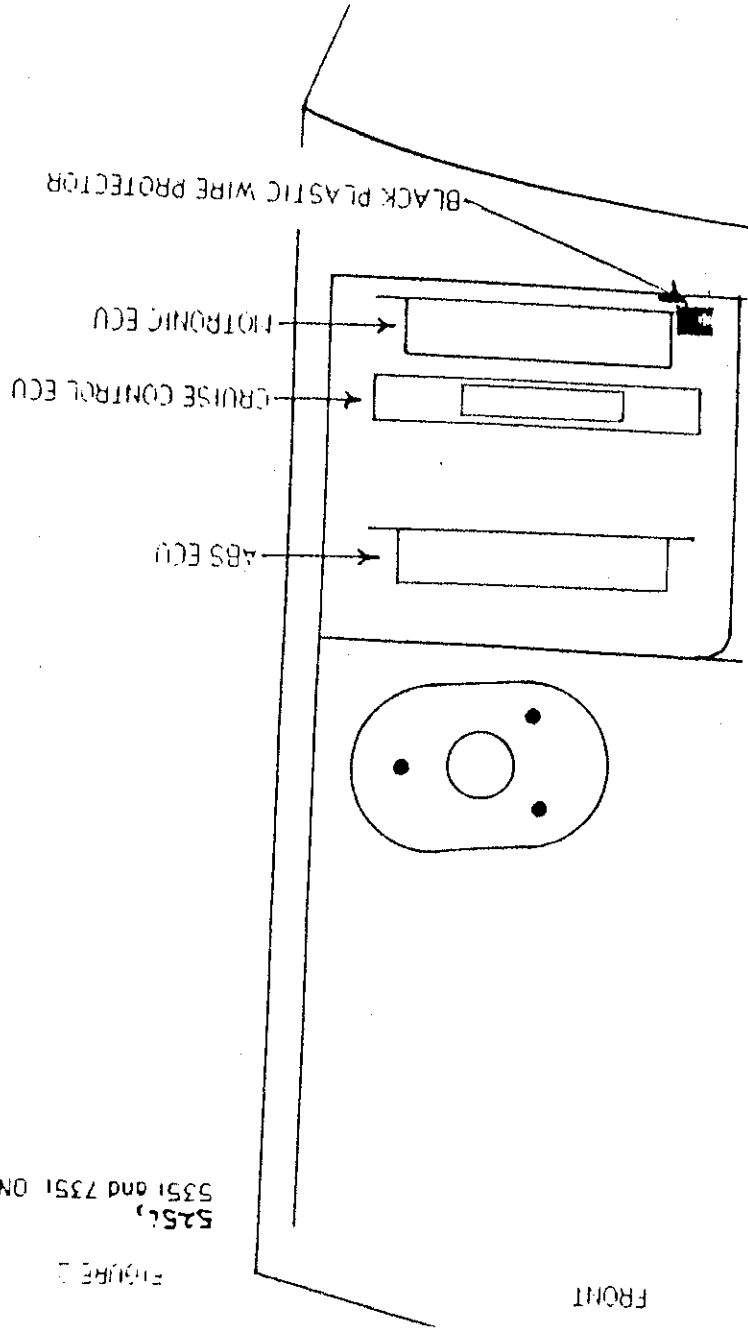

FIGURE 1

FIGURE 3

BEND UP LOCK TABS AS SHOWN

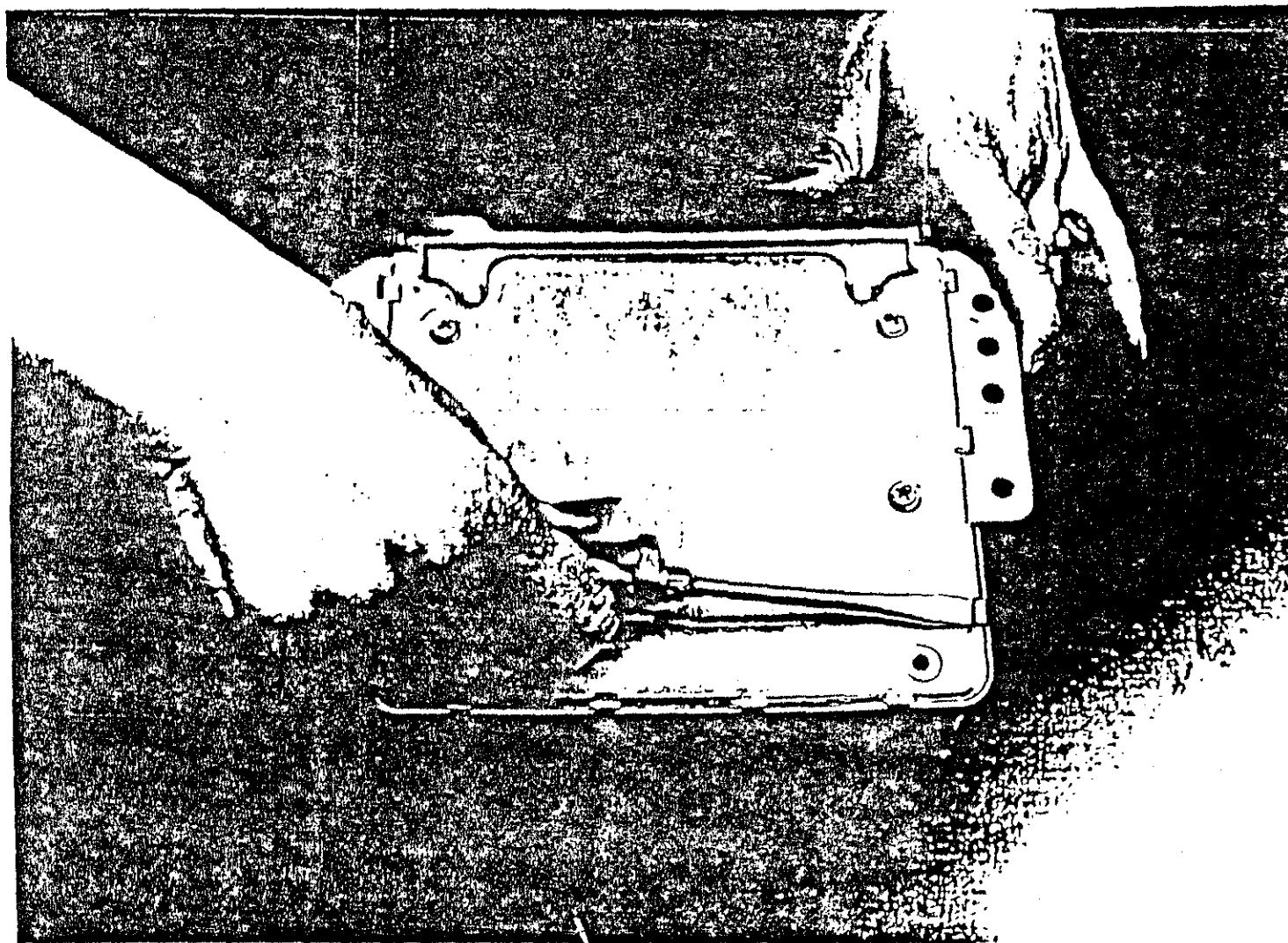

FIGURE 5

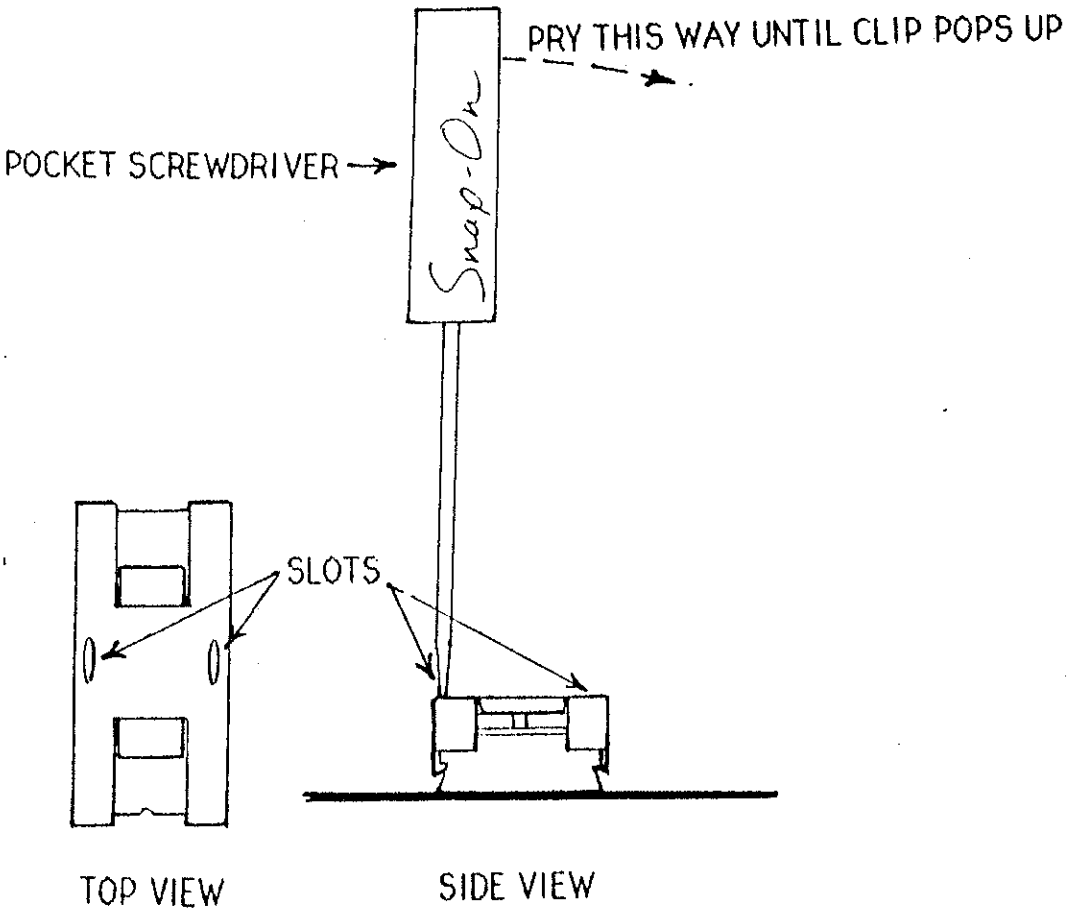
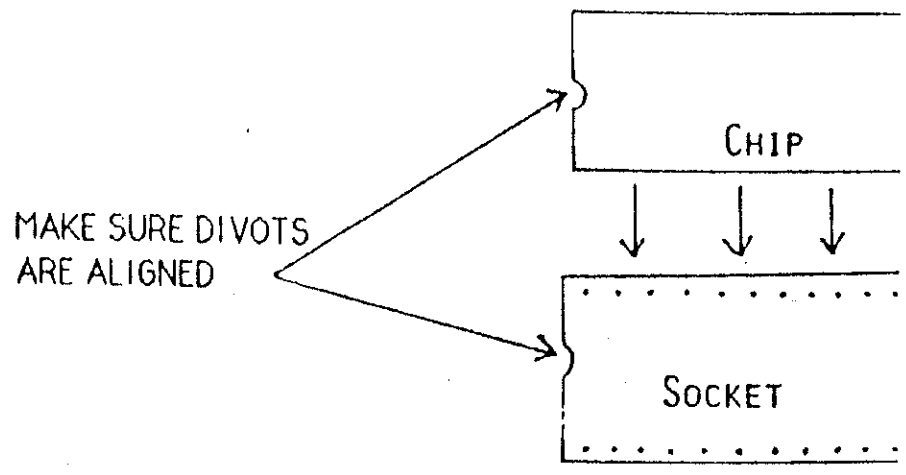

FIGURE 6



**DINAN ENGINEERING PERFORMANCE CHIP INSTALLATION
FOR MOTRONIC-2**

1984-1986 Porsche 911 Carrera BOSCH ECU #0-261-200-050

1987-1988 Porsche 911 Carrera BOSCH ECU #0-261-200-082

Thank you for purchasing a Dinan Engineering performance chip. Many hours of research and development have gone into each program to optimize ignition and fuel delivery curves for maximum power.

Some mechanical skill is required to perform this operation. If you feel that you do not possess the required skill please arrange to have a qualified repair facility do the installation for you.

If you encounter any difficulties during this installation or if these instructions are not clear to you please call Dinan Engineering for assistance @ 415-962-9417.

TOOLS REQUIRED FOR INSTALLATION:

- Standard screwdriver (small)
- Standard screwdriver (pocket size)
- 10mm socket on 3/8 or 1/4 drive ratchet with 1" extension
- Blunt nose pliers (medium)

REMOVE ELECTRONIC CONTROL UNIT (ECU) FROM VEHICLE:

1. Open drivers door. Pull back carpet under drivers seat to expose ECU.
2. Remove nuts securing ECU to floor. Lift ECU up and out from under the seat and unplug wiring harness from ECU.
3. Take ECU to workbench.

ON THE WORKBENCH:

4. Read Bosch part number on ECU. Should be:

0-261-200-050 or

0-261-200-082

If your computer does not display one of these part numbers call Dinan Engineering @ 415-962-9417. DO NOT install the power chip!

5. See figure 1. Place ECU on workbench with part number label face down and using the pocket screwdriver pry the ten lock tabs that hold the unit together up slightly. Just enough to get the small screwdriver under the tabs and finish prying the tabs straight up. Separate case, set cover aside.

6. See figure 2 and figure 3. Hold ECU with metal side down and the plug end facing away. Grip mounting tabs with both hands and push up on upper printed circuit (PC) board where the two plastic pedestals connect to the PC board. The object here is to separate the pedestal snap connections. **Caution! DO NOT PUSH UP ON CORNERS OF PC BOARD OR BOARD WILL FLEX AND BREAK!**

7. Raise rear portion of board which was just unsnapped and slide board away from plug, until the board disengages from the plug housing. Flip over upper PC board so that both PC boards are face up.

8. See figure 4. Find socketed chip on the upper board. This chip can be identified by a sticker with a series of numbers printed on it and that it is elevated higher than any similar chip on the board.

9. Remove chip from socket by inserting the pocket screwdriver between the chip and the socket and prying up gently. Pry up in stages switching ends as you go until the chip is totally loose. Set stock chip aside.

10. See figure 5. Notice the small divot on one end of the power chip. Notice a similar divot on one end of the socket. The chip must be inserted so that both divots are on the same side. First insert one row of pins in one side of the socket part-way. With two fingers push on the other side of the chip until the other row of pins line up with the socket and then push down on chip. Use your other hand to support the bottom side of the PC board directly below the socket while you push down on chip to make sure that it is inserted all the way. **Caution! BE CAREFUL NOT TO BEND ANY PINS.**

Visually verify that all the pins are in a socket hole and that all socket holes are filled with pins.

11. Reassemble PC boards. Reinstall cover on ECU making sure to insert the white plastic sheet first. Use pliers to bend cover lock tabs back into place. Install ECU in vehicle.

This chip increases spark advance. This makes it necessary to run Supreme Unleaded Fuel, 91 octane or better.

The information contained on this chip is the sole property of Dinan Engineering and its reproduction is unlawful. Dinan Engineering will prosecute to the full extent of the law

"Smog Legal" in California under; ARB E.O. No. D-XXX

FIGURE 1

BEND UP LOCK TABS AS SHOWN

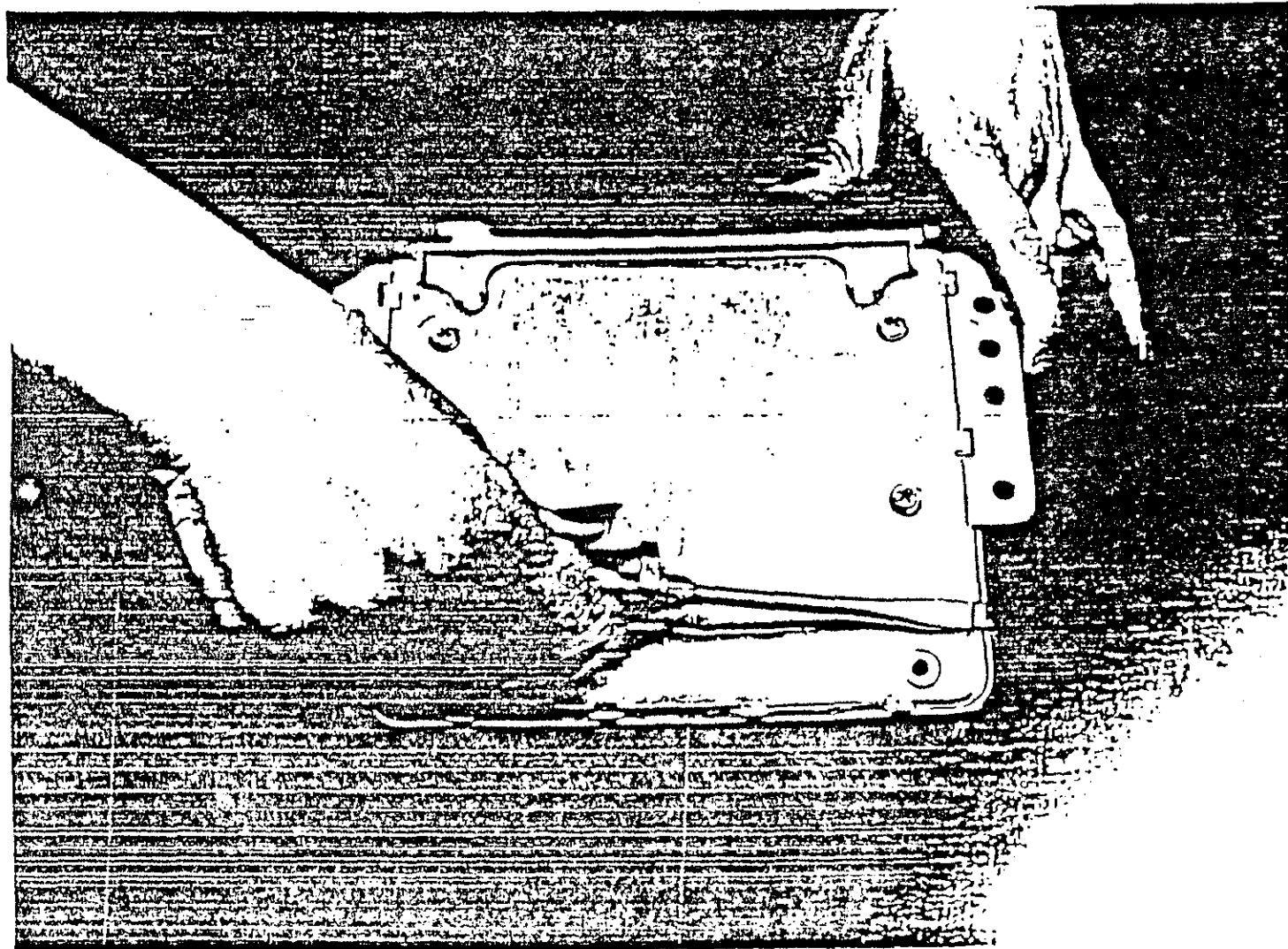

FIGURE.

GRIP MOUNTING TABS AND PUSH UP ON UPPER PC BOARD.
PUSH UP WHERE PLASTIC PEDESTALS ARE, NOT ON THE CORNERS.

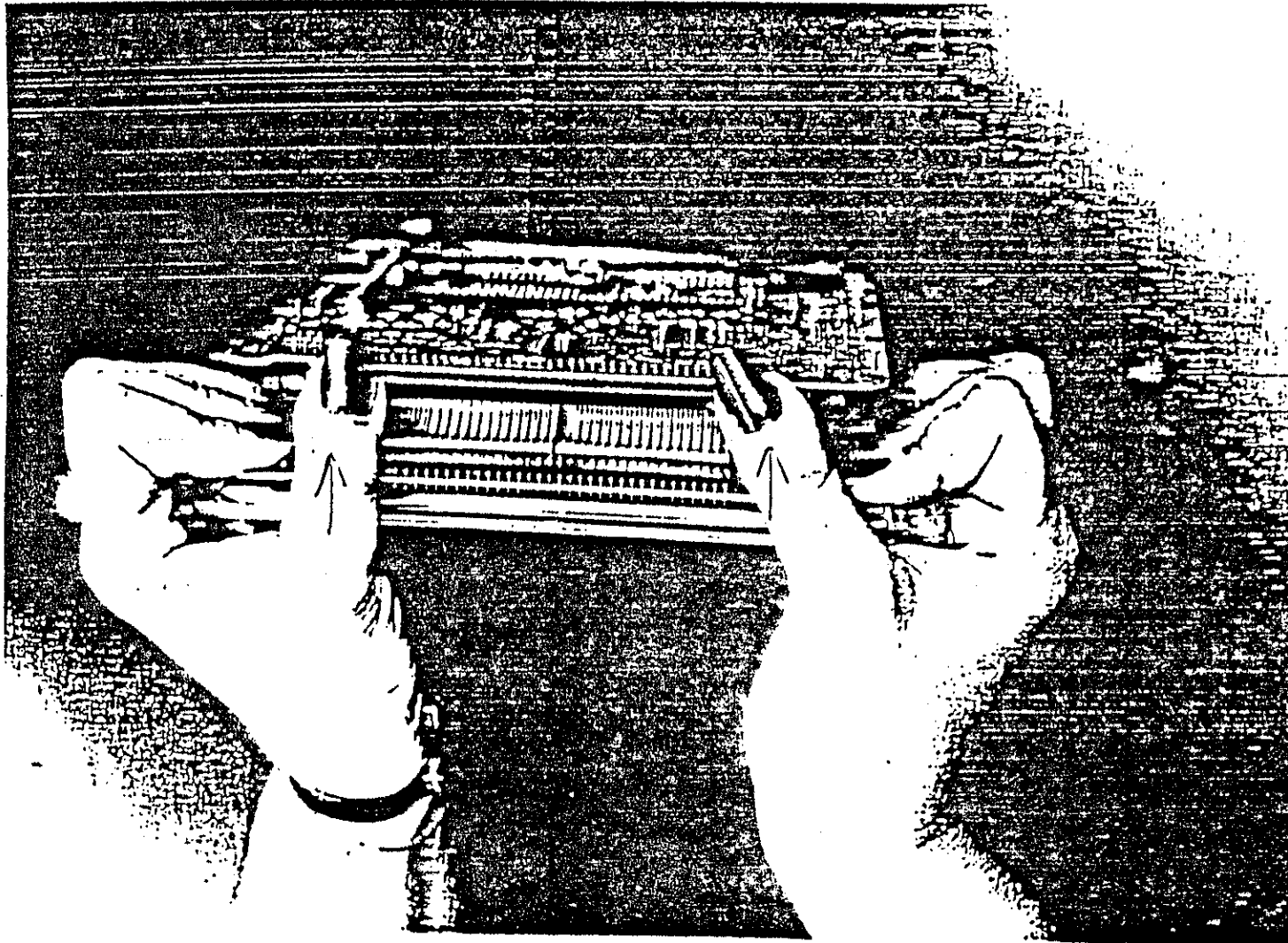
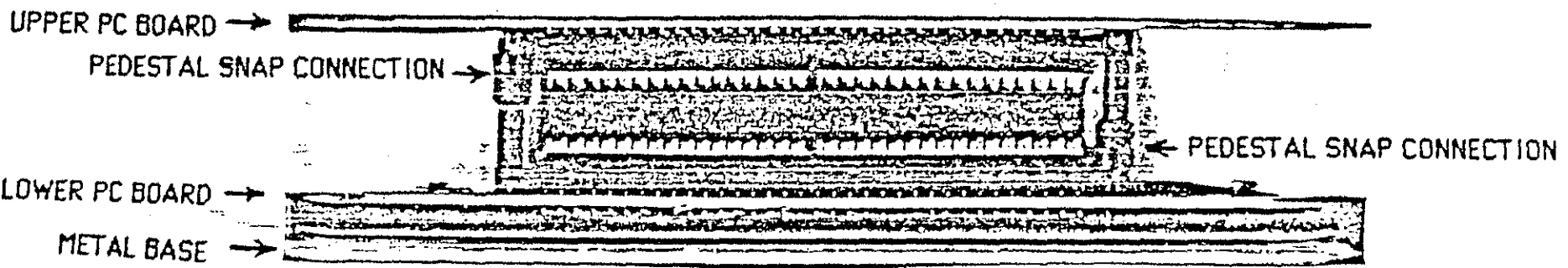
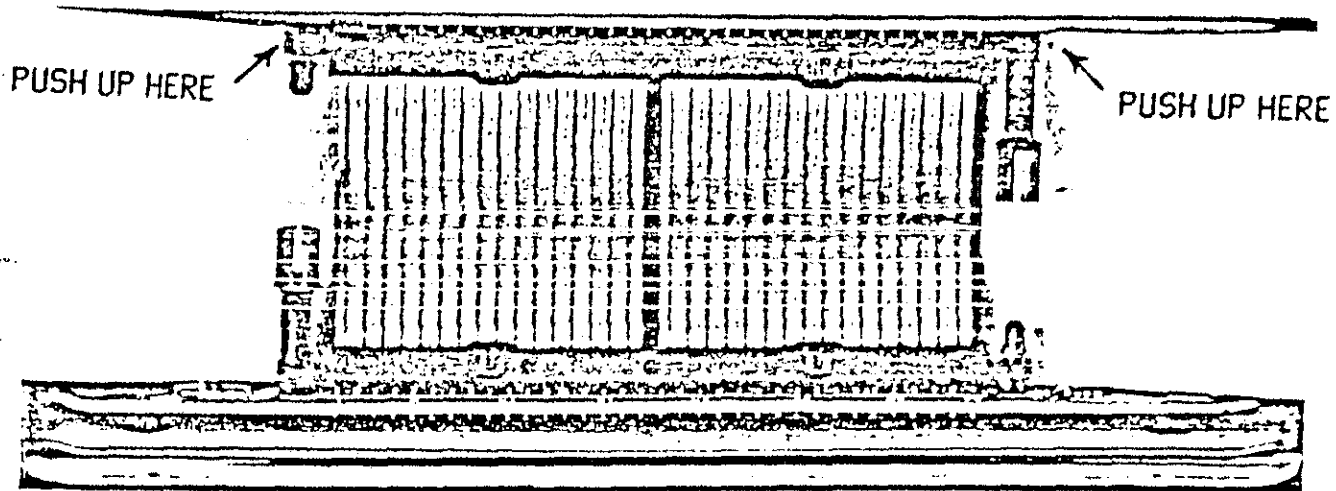

FIGURE 3



PEDESTAL SNAP CONNECTIONS CLOSED



PEDESTAL SNAP CONNECTIONS OPEN

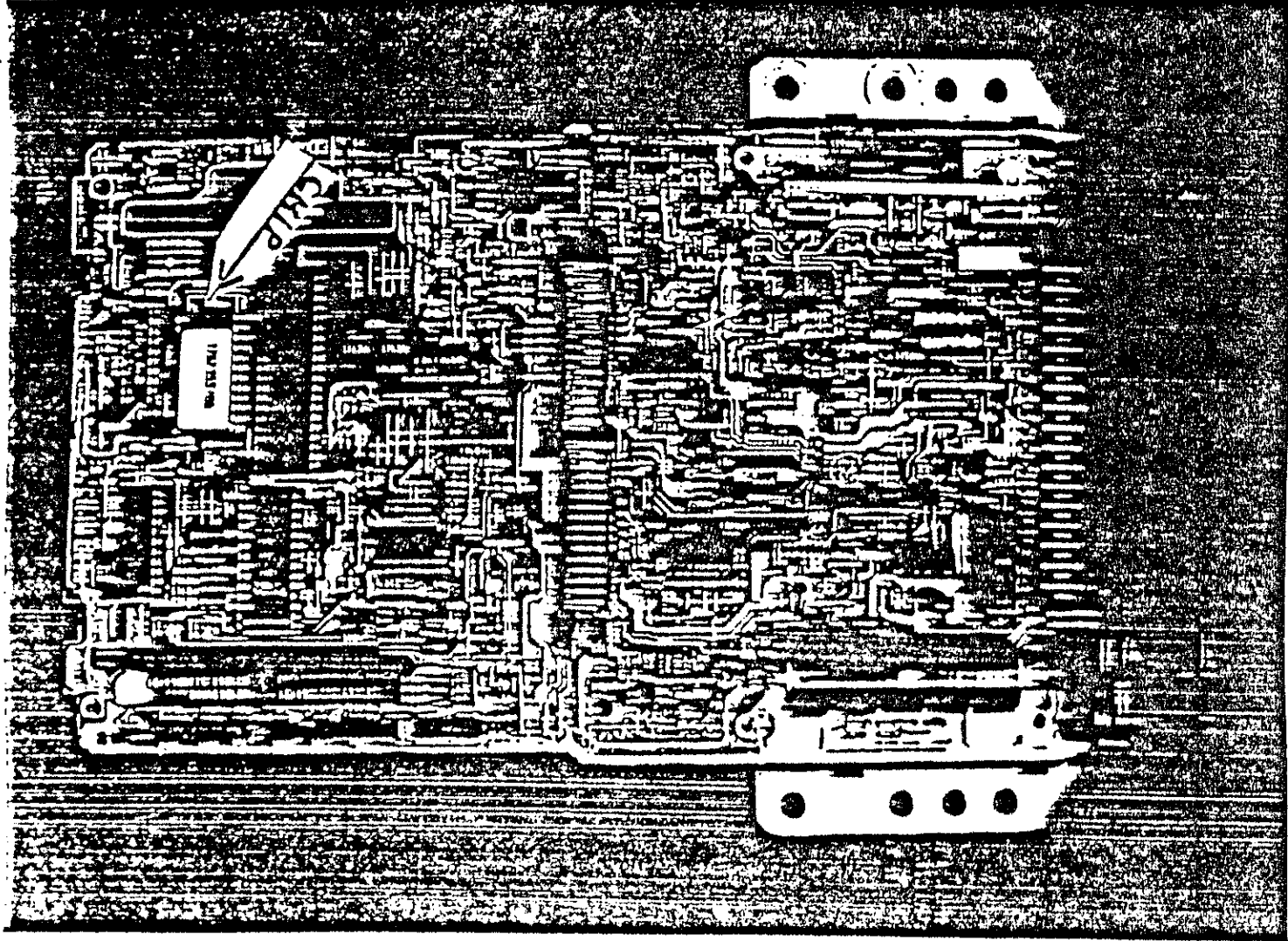

CHIP LOCATION ON BOARD

FIGURE 4

MAKE SURE DIVOTS ARE ALIGNED

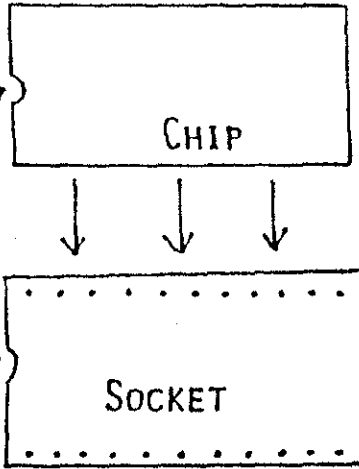

**DINAN ENGINEERING PERFORMANCE CHIP INSTALLATION
FOR MOTRONIC-2
1988 Porsche 924S/944 BOSCH ECU #0-261-200-086**

Thank you for purchasing a Dinan Engineering performance chip. Many hours of research and development have gone into each program to optimize ignition and fuel delivery curves for maximum power.

Some mechanical skill is required to perform this operation. If you feel that you do not possess the required skill please arrange to have a qualified repair facility do the installation for you.

If you encounter any difficulties during this installation or if these instructions are not clear to you please call Dinan Engineering for assistance @ 415-962-9417.

TOOLS REQUIRED FOR INSTALLATION:

- Phillips screwdriver (small)
- Standard screwdriver (small)
- Standard screwdriver (pocket size)
- 8mm socket on 3/8 or 1/4 drive ratchet with 2" extension
- Blunt nose pliers (medium)

REMOVE ELECTRONIC CONTROL UNIT (ECU) FROM VEHICLE:

1. Open drivers door. The ECU is located under the dashboard at the steering column.
2. Remove the phillips screws securing the black plastic cover which conceals the ECU. Remove the four 8mm nut which secure the ECU to the chassis.
3. Let the ECU drop down and unplug the wiring harness from it. Take ECU to workbench.

ON THE WORKBENCH:

4. Read Bosch part number on ECU. Should be:

0-261-200-086

If your computer does not display one of these part numbers call Dinan Engineering @ 415-962-9417. DO NOT install the power chip!

5. See figure 1. Place ECU on workbench with part number label face down and using the pocket screwdriver pry the ten lock tabs that hold the unit together up slightly. Just enough to get the small screwdriver under the tabs and finish prying the tabs straight up. Separate case, set cover aside.

6. See figure 2 and figure 3. Hold ECU with metal side down and the plug end facing away. Grip mounting tabs with both hands and push up on upper printed circuit (PC) board where the two plastic pedestals connect to the PC board. The object here is to separate the pedestal snap connections. **Caution! DO NOT PUSH UP ON CORNERS OF PC BOARD OR BOARD WILL FLEX AND BREAK!**

7. Raise rear portion of board which was just unsnapped and slide board away from plug, until the board disengages from the plug housing. Flip over upper PC board so that both PC boards are face up.

8. See figure 4. Find socketed chip on the upper board. This chip can be identified by a sticker with a series of numbers printed on it and that it is elevated higher than any similar chip on the board.

9. Remove chip from socket by inserting the pocket screwdriver between the chip and the socket and prying up gently. Pry up in stages switching ends as you go until the chip is totally loose. Set stock chip aside.

10. See figure 5. Notice the small divot on one end of the power chip. Notice a similar divot on one end of the socket. The chip must be inserted so that both divots are on the same side. First insert one row of pins in one side of the socket part-way. With two fingers push on the other side of the chip until the other row of pins line up with the socket and then push down on chip. Use your other hand to support the bottom side of the PC board directly below the socket while you push down on chip to make sure that it is inserted all the way. **Caution! BE CAREFUL NOT TO BEND ANY PINS.**

Visually verify that all the pins are in a socket hole and that all socket holes are filled with pins.

11. Reassemble PC boards. Reinstall cover on ECU making sure to insert the white plastic sheet first. Use pliers to bend cover lock tabs back into place. Install ECU in vehicle.

This chip increases spark advance. This makes it necessary to run Supreme Unleaded Fuel, 91 octane or better.

The information contained on this chip is the sole property of Dinan Engineering and its reproduction is unlawful. Dinan Engineering will prosecute to the full extent of the law.

"Smog Legal" in California under; ARB E.O. No. D-XXX

BEND UP LOCK TABS AS SHOWN

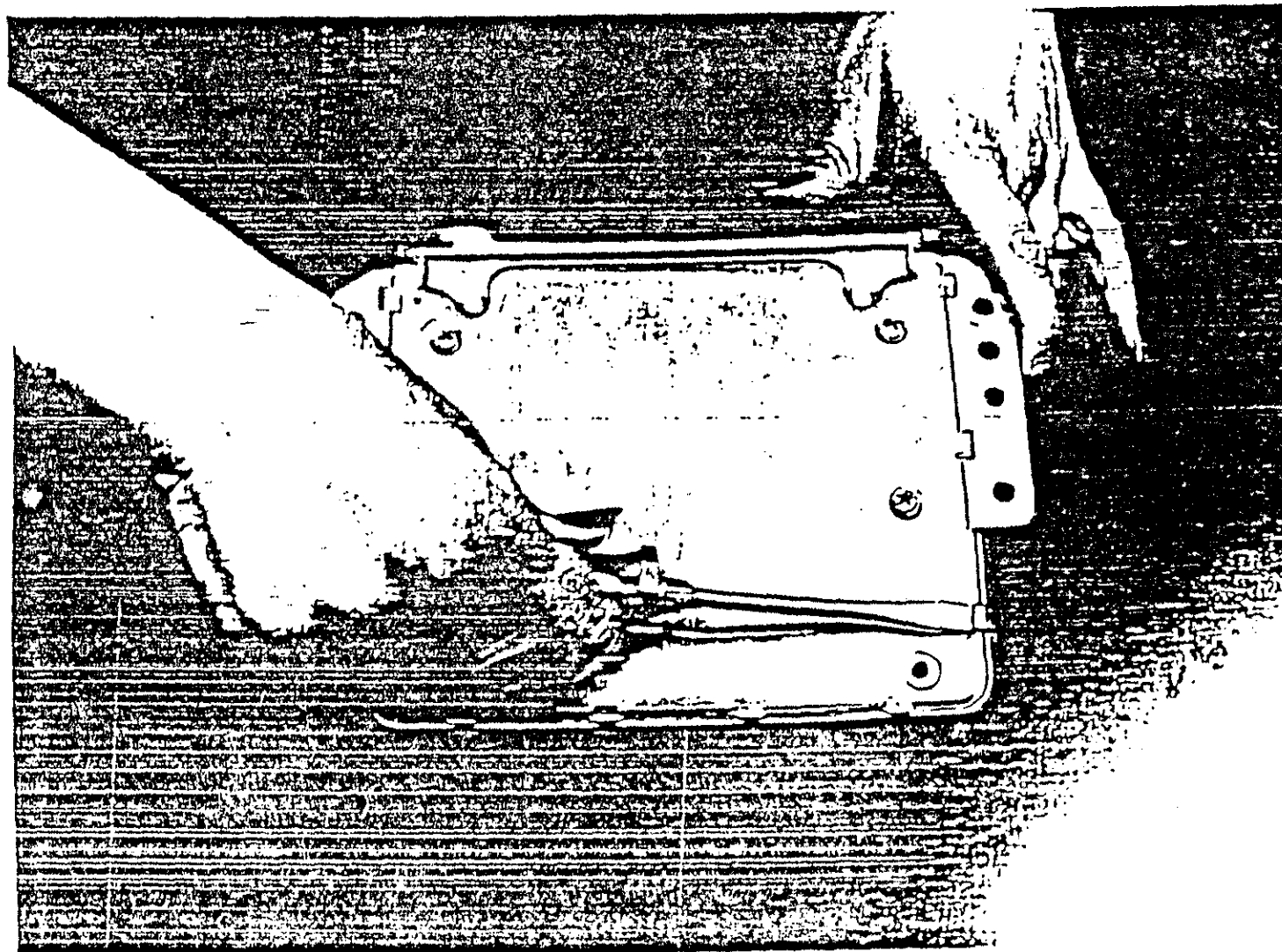
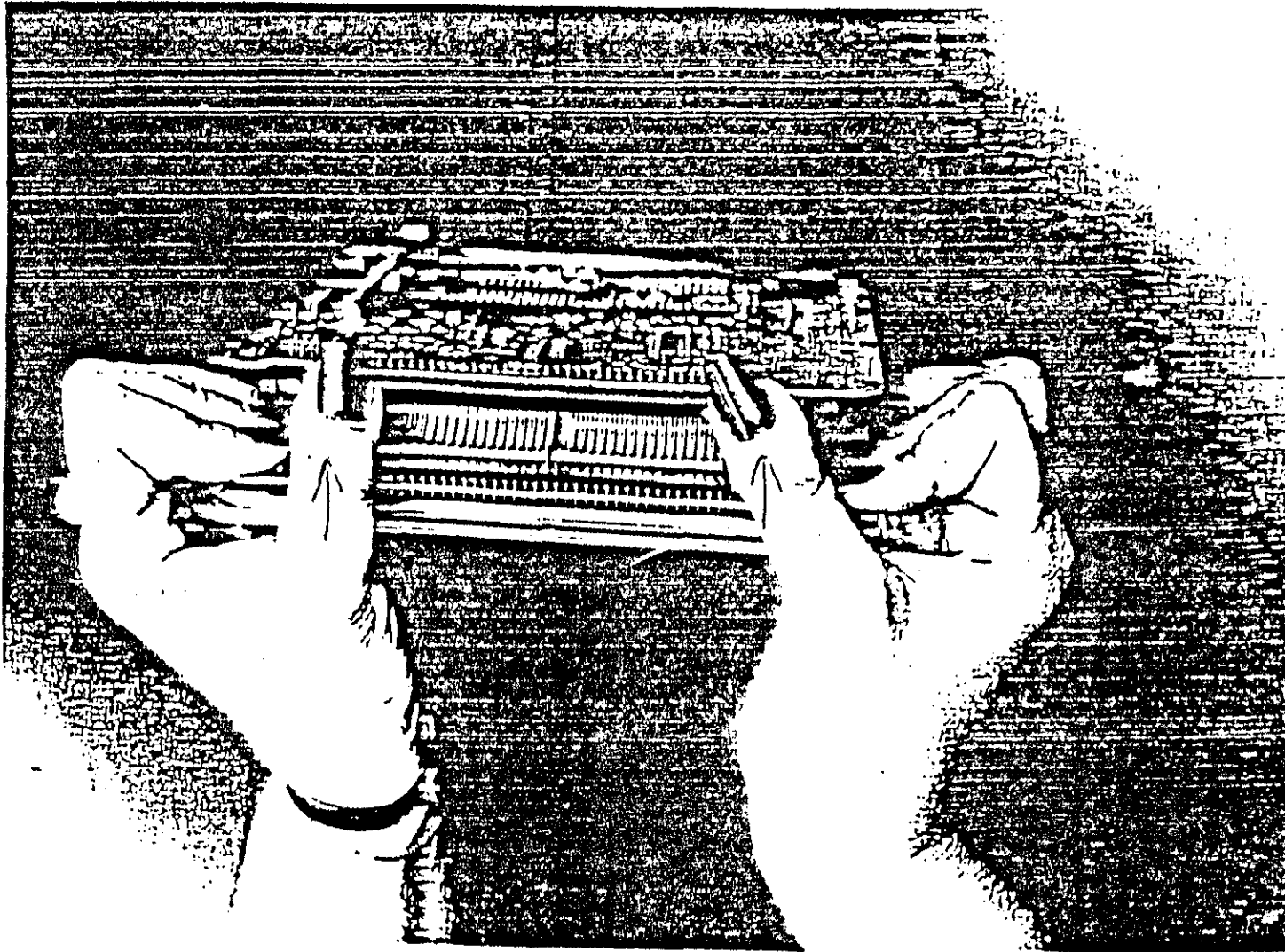

FIGURE 2

GRIP MOUNTING TABS AND PUSH UP ON UPPER PC BOARD.
PUSH UP WHERE PLASTIC PEDESTALS ARE, NOT ON THE CORNERS.



FIGURE

CHIP LOCATION ON BOARD

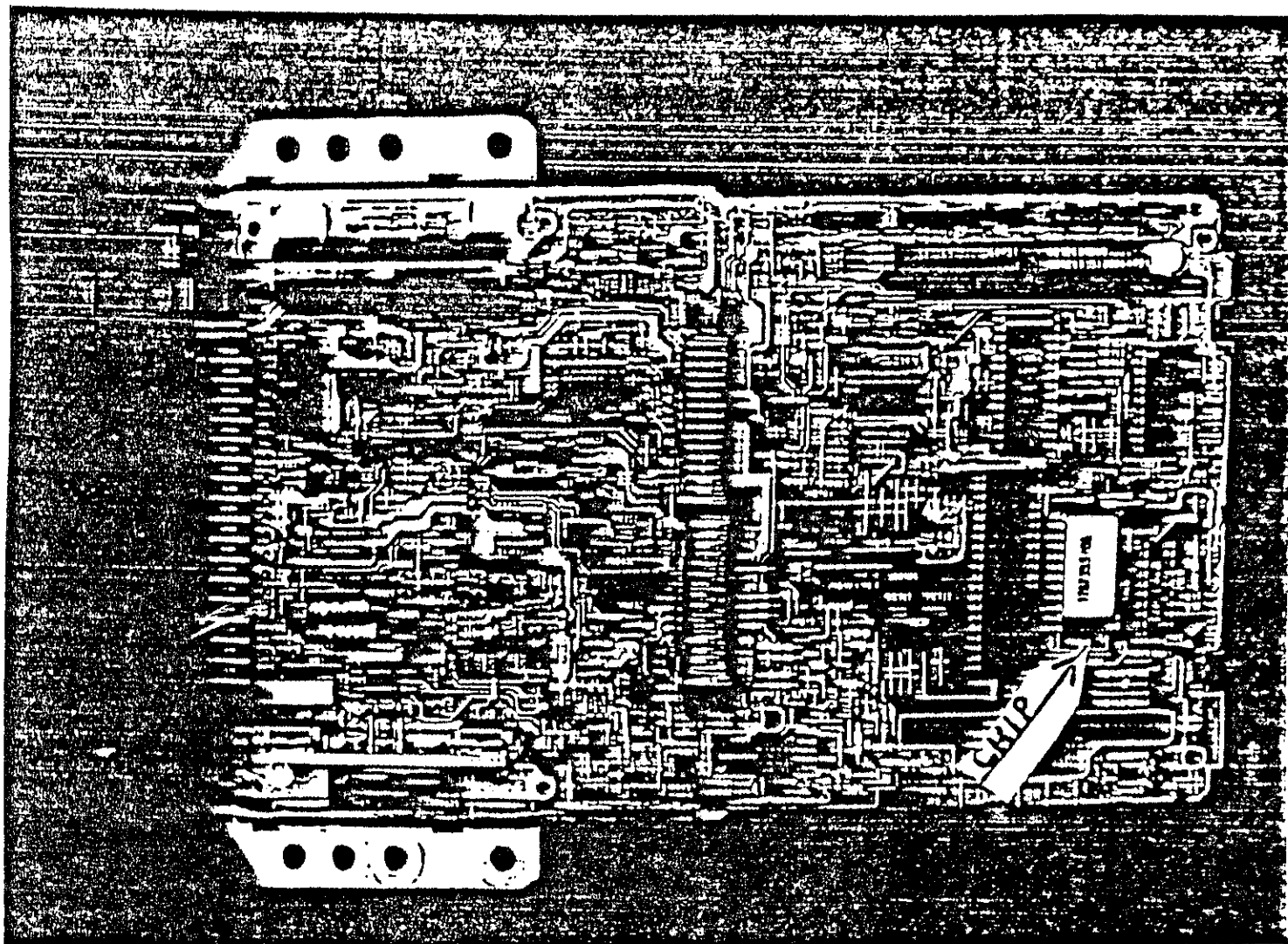
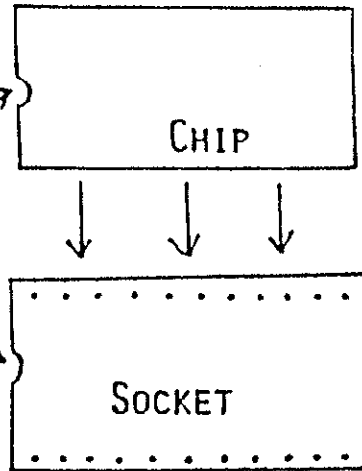

FIGURE 3

MAKE SURE DIVOTS ARE ALIGNED



DINAN ENGINEERING PERFORMANCE CHIP INSTALLATION
MOTRONIC-3 Version 3
1990-→ 318is BOSCH ECU #0-261-200-175

Thank you for purchasing a Dinan Engineering power chip. Many hours of research and development have gone into each program to optimize ignition and fuel delivery curves for maximum power.

Some mechanical skill is required to perform this operation. If you feel that you do not possess the required skill please arrange to have a qualified repair facility do the installation for you.

If you encounter any difficulties during this installation or if these instructions are not clear to you please call Dinan Engineering for assistance @ 415-962-9417.

TOOLS REQUIRED FOR INSTALLATION:

- Phillips screwdriver (medium)
- Standard screwdriver (small)
- Standard screwdriver (pocket size)
- 10mm socket on 3/8 or 1/4 drive ratchet with 2" extension
- #20 "TORX" wrench/driver
- Blunt nose pliers (medium)

REMOVE ELECTRONIC CONTROL UNIT (ECU) FROM VEHICLE:

1. Open glove box, remove pins securing limiting straps to sides of glove box and allow glove box to open all the way.
2. Remove the fasteners securing plastic glove box roof panel. Pull this panel down and allow it to rest in the glove box.
3. Remove wiring harness from ECU by pulling on the metal latch mechanism. Loosen (do not remove) the four 10mm nuts securing the metal plate underneath the ECU. With the nuts sufficiently loose the ECU should slide out. Take ECU to the workbench.

ON THE WORKBENCH:

4. Read Bosch part number on ECU. Should be:

0-261-200-175

If your computer does not display this part number call Dinan Engineering @ 415-962-9417. DO NOT install the power chip!

5. Place ECU on the workbench with part number label face up and remove the four #20 torx screws securing the cover of the case.
6. See figure 1. Place ECU on workbench with part number label face down and using the pocket screwdriver pry the six lock tabs that hold the unit together up slightly. Just enough to get the small screwdriver under the tabs and finish prying the tabs straight up. Separate case, set cover aside.
7. See figure 2. Find the socketed chip on the board. This chip can be identified by the plastic "H" shaped retaining clip locking it into the socket and that it is elevated higher than any similar chip on the board.
8. See figure 3. Remove the "H" shaped retaining clip by inserting the pocket screwdriver into one of the small slots in the retaining clip and prying towards the other slot. The retaining clip will pop up on the side the screwdriver is inserted in, use a finger to hold that side up while you insert the screwdriver in the other slot and release the other side. Lift retaining clip off of the chip and set aside.
9. Remove chip from socket by inserting the pocket screwdriver between the chip and the socket and prying up gently. Pry up in stages switching ends as you go until the chip is totally loose. Set stock chip aside.
10. See figure 4. Notice the small divot on one end of the power chip. Notice a similar divot on one end of the socket. The chip must be inserted so that both divots are on the same side. First insert one row of pins in one side of the socket part-way. With two fingers push on the other side of the chip until the other row of pins line up with the socket and then push down on chip and make sure that it is inserted all the way. **Caution! BE CAREFUL NOT TO BEND ANY PINS.** Visually verify that all the pins are in a socket hole and that all socket holes are filled with pins.
12. Reinstall retaining clip. Reinstall cover on ECU; use pliers to bend cover lock tabs back into place. Install the four screws removed in step 5. Install ECU in vehicle.

The 318is requires supreme unleaded fuel in the stock form. Supreme unleaded must be used with the power chip. As with the stock vehicle, if supreme is not used, engine damage may result.

The information contained on this chip is the sole property of Dinan Engineering and its reproduction is unlawful. Dinan Engineering will prosecute to the full extent of the law.

"Smog Legal" in California under; CARB E. O. No. D-XXX

FIGURE 1

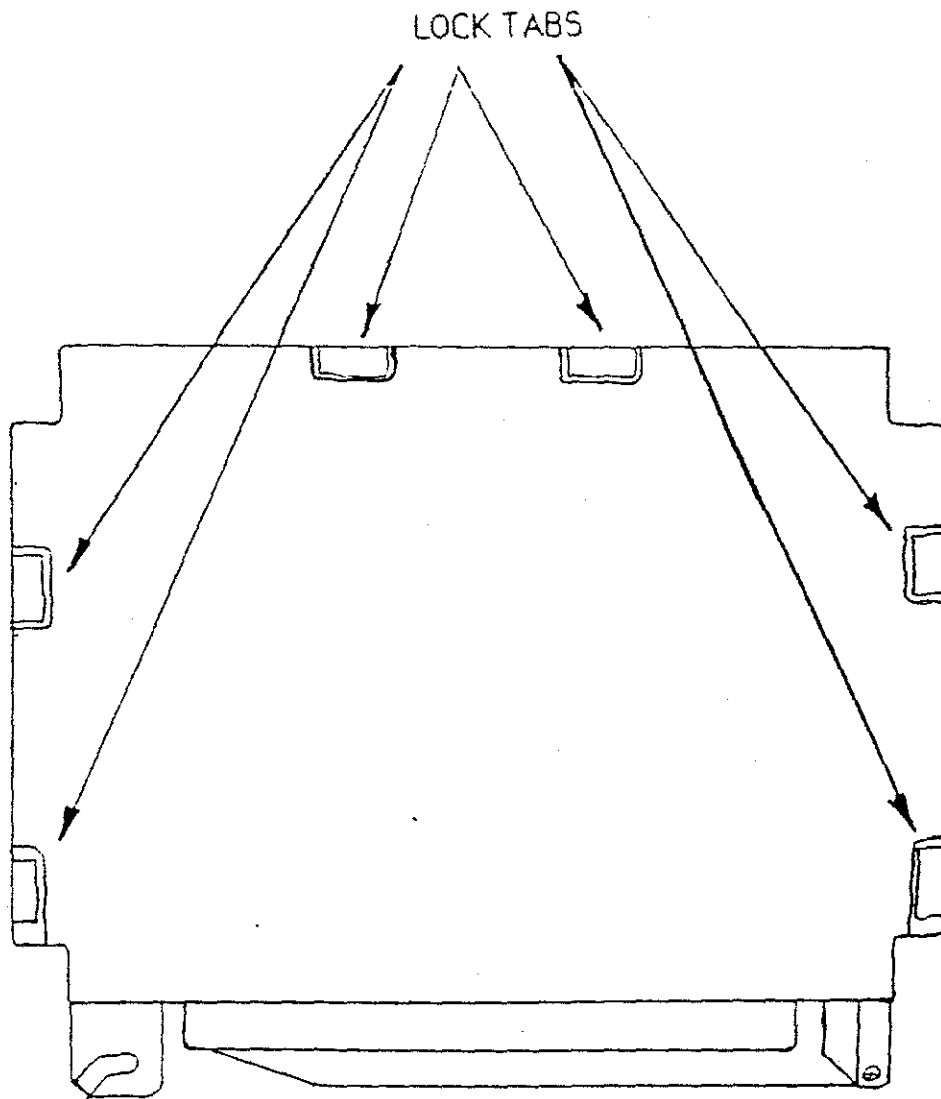
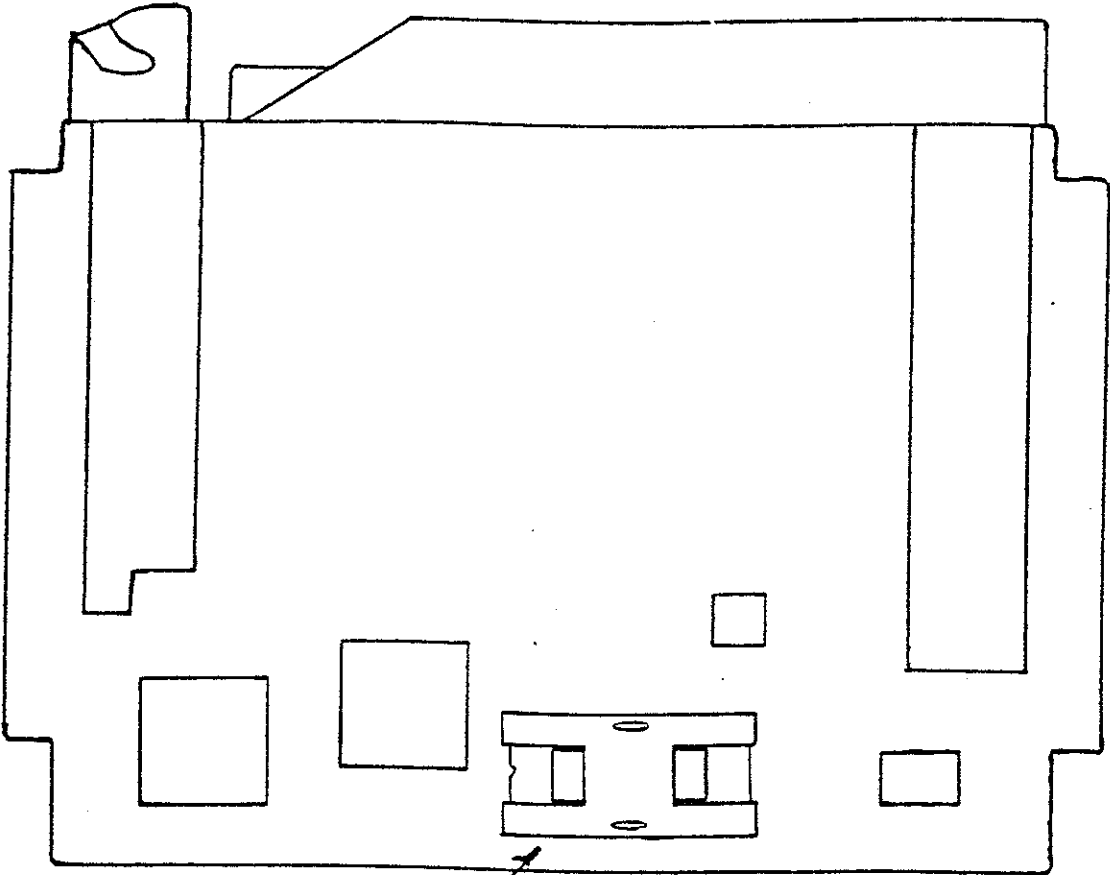

FIGURE 2



SOCKETED CHIP

FIGURE 3

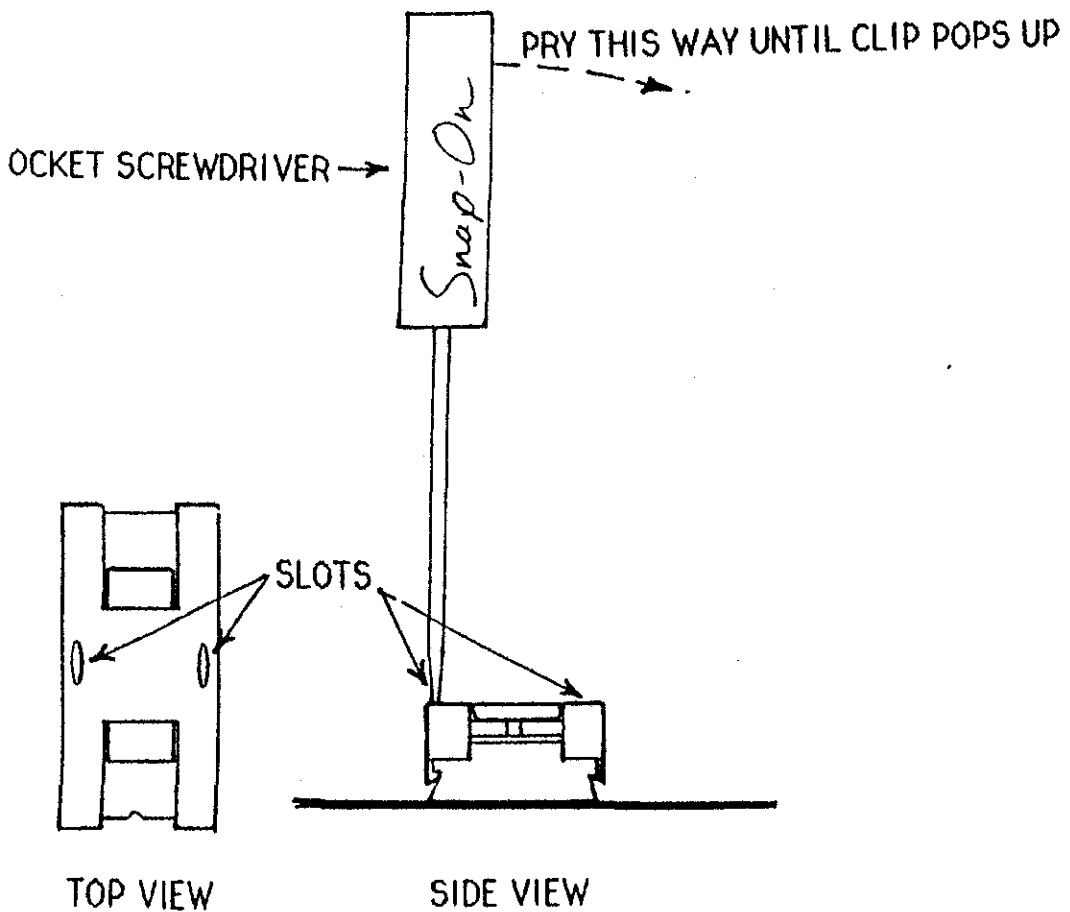

FIGURE 4

