

State of California
AIR RESOURCES BOARD

EXECUTIVE ORDER D-203-1
Relating to Exemptions Under Section 27156
of the Vehicle Code

SOFTRON INTERNATIONAL
SOFTRON MODEL #100 FLUID CONDITIONER

WHEREAS, Vehicle Code Section 27156 and Title 13 California Code of Regulations (hereafter "CCR") Section 2222(e), authorize the California Air Resources Board (ARB) and its Executive Officer to exempt add-on and modified parts from the prohibitions of Vehicle Code Section 27156.

WHEREAS, Softron International has applied to the ARB for exemption from the prohibitions of Vehicle Code Section 27156 for the Softron model #100 fluid conditioner for 1991 and older model years.

WHEREAS, pursuant to the authority vested in the Executive Officer by Health and Safety Code Section 39515 and in the Chief, Mobile Source Division by Health and Safety Code Section 39516 and Executive Order G-45-5, the Air Resources Board finds:

1. The Softron model #100 fluid conditioner is an add-on device attached to the fuel line in a motor vehicle.
2. The Softron model #100 fluid conditioner is intended for use with a required motor vehicle pollution control system.
3. The Softron model #100 fluid conditioner by being installed in the engine alters the original design of a motor vehicle pollution control system.
4. The Softron model #100 fluid conditioner is a device subject to the prohibitions of Vehicle Code Section 27156 and an add-on part as defined by 13 CCR Section 1900(b)(1).
5. The Softron model #100 fluid conditioner does not reduce the effectiveness of any required motor vehicle pollution control device.
6. The Air Resources Board, in the exercise of technical judgement, is aware of no basis on which the Softron model #100 fluid conditioner will provide an increase in fuel economy.

7. It has not been determined what effect use of the Softron model #100 fluid conditioner may have on any warranty, either expressed or implied, by the manufacturer of a motor vehicle on which the device is installed.
8. The Softron model #100 fluid conditioner is not a certified motor vehicle pollution control device pursuant to Health and Safety Code Section 43644.
9. The Air Resources Board by granting an exemption to Softron International for the Softron model #100 fluid conditioner does not recommend or endorse in any way the Softron model #100 fluid conditioner for emissions reduction, fuel economy, or any other purpose.

IT IS HEREBY RESOLVED that the Softron model #100 fluid conditioner is exempt from the prohibitions of Vehicle Code Section 27156 for installation on 1991 and earlier model-year vehicles powered with gasoline or diesel internal combustion engines subject to the following conditions:

1. This exemption shall not apply to any device, apparatus, or mechanism advertised, offered for sale or sold with, or installed on, a motor vehicle prior to or concurrent with transfer to an ultimate purchaser.
2. No changes are permitted to the device as described in the application for exemption. Any changes to the device, applicable model year, or other factors addressed in this order must be evaluated and approved by the Air Resources Board prior to marketing in California.
3. Marketing of this device using an identification other than that shown in this Executive Order or marketing of this device for an application other than those listed in the Executive Order shall be prohibited unless prior approval is obtained from the Air Resources Board. Exemption of this product shall not be construed as an exemption to sell, offer for sale, or advertise any component of the product as an individual device.
4. Any oral or written references to this Executive Order or its content by Softron International, its principals, agents, employees, distributors, dealers, or other representatives must include the disclaimer that the Executive Order or the exemption it provides is not an endorsement or approval of any fuel economy or emissions reduction claims for the Softron model #100 fluid conditioner and is only a finding that the device is exempt from the prohibitions of Vehicle Code Section 27156.

5. No claim of any kind, such as "Approved by the Air Resources Board" may be made with respect to the action taken herein in any advertising or other oral or written communication.

Violation of any of the above conditions shall be grounds for revocation of this order. The order may be revoked only after ten day written notice of intention to revoke the order, in which period the holder of the order may request in writing a hearing to contest the proposed revocation. If a hearing is requested, it shall be held within ten days of receipt of the request and the order may not be revoked until a determination after hearing that grounds for revocation exist.

Executed at El Monte, California, this 31st day of July, 1990.

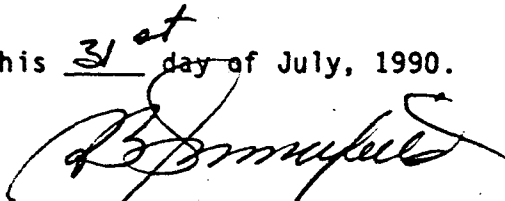

R. B. Summerfield
Assistant Division Chief
Mobile Source Division

TYPICAL INSTALLATION

Unit should be placed after fuel pump and fuel filter *as close as possible* to carburetor or fuel injector

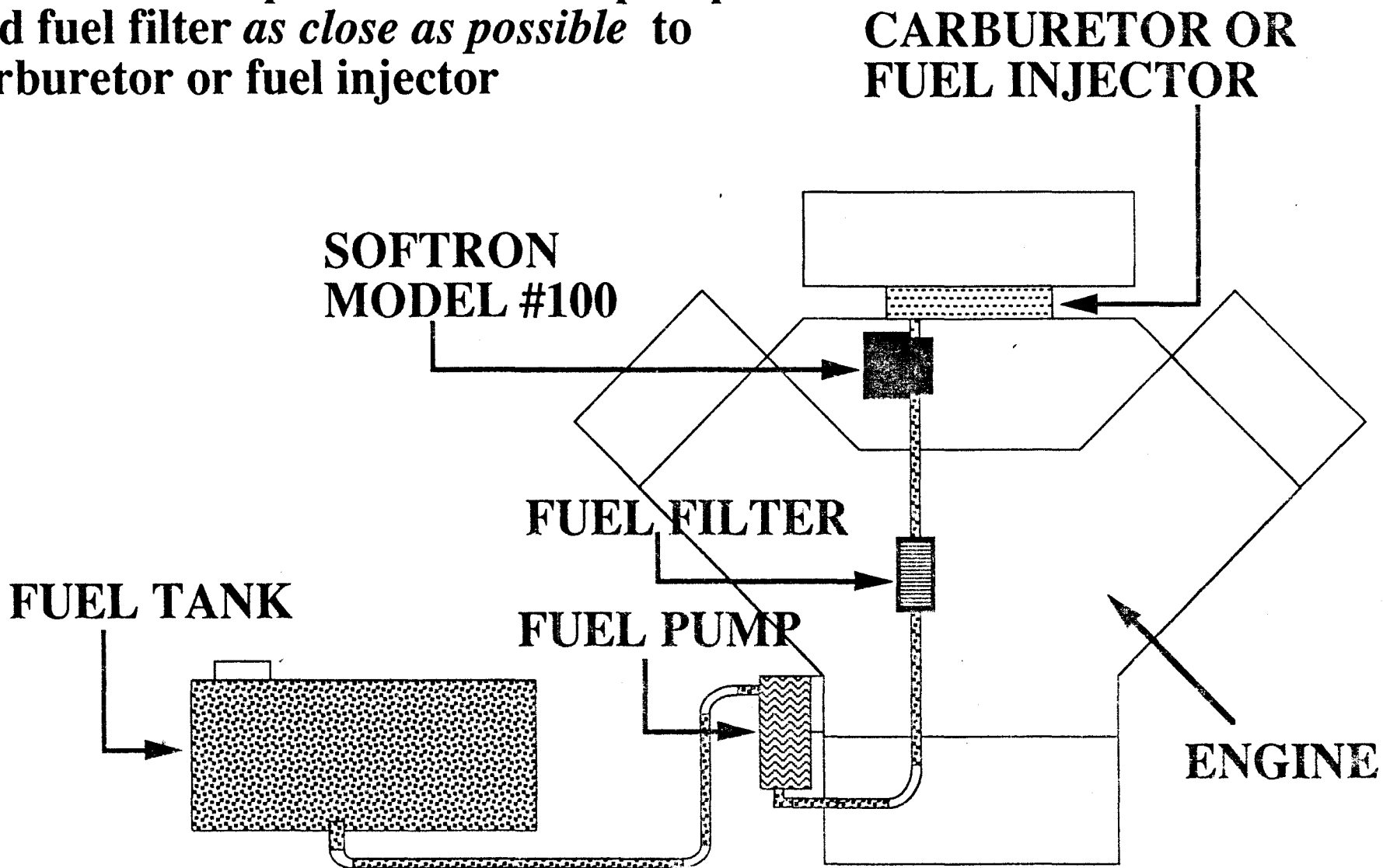

REVISIONS				
ZONE	REV	DESCRIPTION	DATE	APPROVED

APPENDIX A

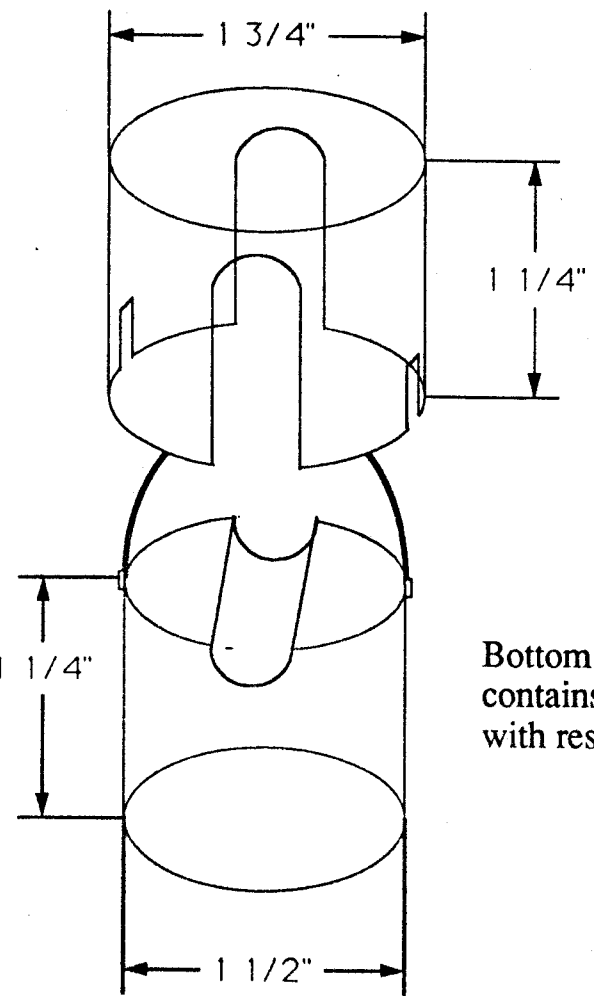

Stainless Steel grade #304
top cover.

Bottom , Stainless Steel grade #304
contains magnet assembly and is filled
with resin.

NOTE: All dimensions in inches unless otherwise noted.

ITEM	QUANTITY	NAME	DESCRIPTION	SIZE
PARTS LIST AND DESCRIPTION				
TOLERANCES		SOFTRON INTERNATIONAL 13757 Seminole Chino CA 91710 <hr/> SOFTRON MODEL #100		
.X	±.015			
.XX	±.010			
.XXX	±.005			
UNLESS OTHERWISE SPECIFIED				
DRAWN	MS	B	FSCM NO.	DWG NO. BB 100-1.LSWR
ISSUED	June 13, '90	SCALE Full	WEIGHT	SHEET 1