

State of California
AIR RESOURCES BOARD

EXECUTIVE ORDER D-242
Relating to Exemptions Under Section 27156
of the Vehicle Code

PROFESSIONAL FLOW TECHNOLOGIES
PRO M MASS AIR FLOW SENSOR

Pursuant to the authority vested in the Air Resources Board by Section 27156 of the Vehicle Code; and

Pursuant to the authority vested in the undersigned by Sections 39515 and 39516 of the Health and Safety Code and Executive Order G-45-5;

IT IS ORDERED AND RESOLVED: That the installation of the Pro M Mass Air Flow Sensor, manufactured by Professional Flow Technologies, 25740 John R, Madison Heights, MI 48071, has been found not to reduce the effectiveness of the applicable vehicle pollution control system and, therefore, is exempt from the prohibitions of Section 27156 of the Vehicle Code for 1988-1991 model-year Ford Mustangs equipped with 5.0L engines and 1990-1992 model-year Ford Thunderbird Super Coupe vehicles equipped with 3.8L engines.

This Executive Order is valid provided that installation instructions for this Pro M Mass Air Flow Sensor will not recommend tuning the vehicle to specifications different from those submitted by Professional Flow Technologies.

Changes made to the design or operating conditions of the Pro M Mass Air Flow Sensor as exempt by the Air Resources Board (ARB), which adversely affect the performance of a vehicle's pollution control system shall invalidate this Executive Order.

Marketing of this Pro M Mass Air Flow Sensor using any identification other than that shown in this Executive Order or marketing of this Pro M Mass Air Flow Sensor for an application other than those listed in this Executive Order shall be prohibited unless prior approval is obtained from the ARB. Exemption of the Pro M Mass Air Flow Sensor shall not be construed as exemption to sell, offer for sale, or advertise any component of the kit as an individual device.

This Executive Order is granted based on a determination that the device would not show an adverse effect in emissions if tested using the Cold-Start CVS-75 Federal Test Procedure. However, the ARB finds that reasonable grounds exist to believe that use of the Pro M Mass Air Flow Sensor may adversely affect emissions of motor vehicles when operating under conditions outside the parameters of the previously prescribed test procedures. Accordingly, the ARB reserves the right to conduct emission tests, in the future, as such tests are developed, that will more adequately measure emissions from all cycle phases. If such test results demonstrate that the Pro M Mass Air Flow Sensor adversely affects emissions during off-cycle conditions (defined as those conditions which are beyond the parameters of the Cold-Start CVS-75 Federal Test Procedure), this Executive Order shall be

effectively rescinded as of the date the test results are validated. Further, if such test results or other evidence provides the ARB with reason to suspect that the Pro M Mass Air Flow Sensor will affect the durability of the emission control system, Professional Flow Technologies shall be required to submit durability data to show that the durability of the vehicle emission control system is not, in fact, affected and/or that the add-on or modified part demonstrates adequate durability.

In addition to the foregoing, the ARB reserves the right in the future to review this Executive Order and the exemption provided herein to assure that the exempted add-on or modified part continues to meet the standards and procedures of Title 13, California Code of Regulations section 2222 et seq.

This Executive Order does not constitute any opinion as to the effect the use of this Pro M Mass Air Flow Sensor may have on any warranty either expressed or implied by the vehicle manufacturer.

THIS EXECUTIVE ORDER DOES NOT CONSTITUTE A CERTIFICATION, ACCREDITATION, APPROVAL, OR ANY OTHER TYPE OF ENDORSEMENT BY THE AIR RESOURCES BOARD OF CLAIMS OF THE APPLICANT CONCERNING ANTI-POLLUTION BENEFITS OR ANY ALLEGED BENEFITS OF THE PROFESSIONAL FLOW TECHNOLOGIES' PRO M MASS AIR FLOW SENSOR.

No claim of any kind, such as "Approved by the Air Resources Board" may be made with respect to the action taken herein in any advertising or other oral or written communication.

Violation of any of the above conditions shall be grounds for revocation of this order. The order may be revoked only after ten day written notice of intention to revoke the order, in which period the holder of the order may request in writing a hearing to contest the proposed revocation. If a hearing is requested, it shall be held within ten days of receipt of the request and the order may not be revoked until a determination after the hearing that grounds for revocation exist.

Executed at El Monte, California, this 20th day of February, 1992.

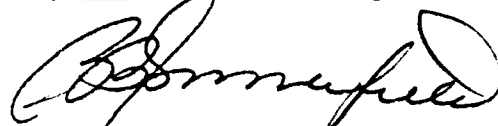

R. B. Summerfield
Assistant Division Chief
Mobile Source Division

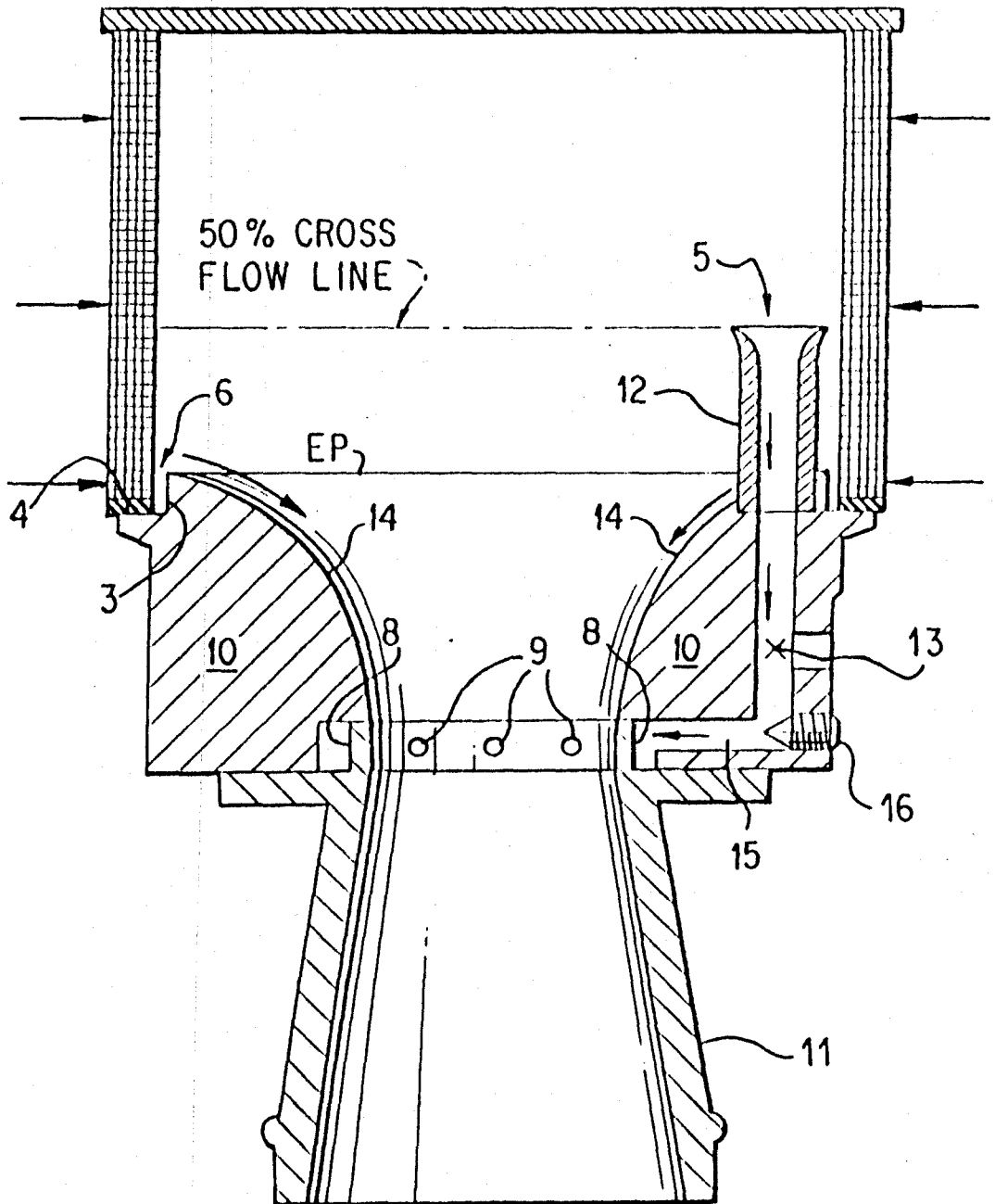

FIG. 6