

State of California  
AIR RESOURCES BOARD

EXECUTIVE ORDER D-447  
Relating to Exemption Under Section 27156  
of the Vehicle Code

FURUTANI TECHNICAL LABORATORY CO., LTD.  
ION TECHNO SHEET/TECHNO FUEL PIPE

WHEREAS, Vehicle Code Section 27156 and Title 13 California Code of Regulations (hereafter "CCR") Section 2222(e), authorize the California Air Resources Board (ARB) and its Executive Officer to exempt add-on and modified parts from the prohibitions of Vehicle Code Section 27156.

WHEREAS, Furutani Technical laboratory Co., Ltd. of 3-3-3, Nishi Yomeshima-cho, Matsue 690 Japan, has applied to the ARB for exemption from the prohibitions of Vehicle Code Section 27156 for the Ion Techno Sheet/Techno Fuel Pipe.

WHEREAS, pursuant to the authority vested in the Executive Officer by Health and Safety Code Section 39515 and in the Chief, Mobile Source Division by Health and Safety Code Section 39516 and Executive Order G-45-9, the ARB finds:

1. The Ion Techno Sheet/Techno Fuel Pipe is an add-on device that is attached to the air cleaner and fuel line, respectively, in a motor vehicle.
2. The air cleaner and fuel line are part of the required motor vehicle pollution control system.
3. The Ion Techno Sheet/Techno Fuel Pipe are intended for use with a required pollution control system.
4. The Ion Techno Sheet/Techno Fuel Pipe by being installed on the air cleaner and fuel line alters the original design of a motor vehicle pollution control system.

5. The Ion Techno Sheet/ Techno Fuel Pipe is a device subject to the prohibitions of Vehicle Code Section 27156 and an add-on part as defined by Title 13, CCR Section 1900(b)(1).
6. The Ion Techno Sheet/Techno Fuel Pipe does not reduce the effectiveness of any required motor vehicle pollution control device.
7. The ARB has not determined the effect the use of the Ion Techno Sheet/Techno Fuel Pipe has on any warranty, either expressed or implied, by the manufacturer or a motor vehicle on which the device is installed.
8. The Ion Techno Sheet/Techno Fuel Pipe is not a certified motor vehicle pollution control device pursuant to Health and Safety Code Section 43644.
9. The ARB by granting an exemption to Furutani Technical Laboratory Co., Ltd. for the Ion Techno Sheet/Techno Fuel Pipe does not recommend or endorse in any way the Ion Techno Sheet/Techno Fuel Pipe for emissions reduction, fuel economy, or any other purpose.
10. Submitted emission test data from an independent laboratory showed the Ion Techno Sheet/Techno Fuel Pipe did not adversely affect exhaust emissions on the two vehicles tested. The test results are shown below.

Automobile Club of Southern California  
Los Angeles, California

1.6L Honda Civic

	<u>HC</u>	<u>CO</u>	<u>NOx</u>
Baseline (g/mi)	0.122	1.792	0.071
Device (g/mi)	0.146	1.823	0.070
Change (g/mi)	+0.024	+0.031	-0.001
Percent Change	+19.67	+1.73	-1.41

4.6L Ford Pickup Truck

	<u>HC</u>	<u>CO</u>	<u>NO<sub>x</sub></u>
Baseline (g/mi)	0.161	1.975	0.083
Device (g/mi)	0.154	1.929	0.075
Change (g/mi)	-0.007	-0.046	-0.008
Percent Change	-4.35	-2.23	-9.64

The change in emissions on the above test results are within the test-to-test variability specified in the "Procedures for Exemption of Add-on and Modified Parts." The same emissions impact is expected when this device is used on the vehicles for which this exemption is requested.

IT IS HEREBY RESOLVED that the Ion Techno Sheet/Techno Fuel Pipe is exempt from the prohibitions of Vehicle Code Section 27156 for installation on 1997 and older model-year gasoline and diesel powered vehicles, excluding those vehicles subject to Ultra-Low Emission Vehicle (ULEV), Low Emission Vehicle (LEV), Transitional Low Emission Vehicle (TLEV) standards or enhanced evaporative emission standards, subject to the following conditions:

1. This exemption shall not apply to any device, apparatus, or mechanism advertised, offered for sale or sold with, or installed on, a motor vehicle prior to or concurrent with transfer to an ultimate purchaser.
2. No changes are permitted to the device as described in the application for exemption. Any changes to the device, applicable model year, or other factors addressed in this order must be evaluated and approved by the ARB prior to marketing in California.
3. Marketing of this device using an identification other than that shown in this Executive Order or marketing of this device for an application other than those listed in this Executive Order shall be prohibited unless prior approval is obtained from the ARB. Exemption of this product shall not be construed as an exemption to sell, offer for sale, or advertise any component of the product as an individual device.

4. Any oral or written references to this Executive Order or its content by Furutani Technical Laboratory Co., Ltd., its principals, agents, employees, distributors, dealers, or other representatives must include the disclaimer that the Executive Order or the exemption it provides is not an endorsement or approval of any fuel economy or emissions reduction claims for the Ion Techno Sheet/Techno Fuel Pipe and is only a finding that the device is exempt from the prohibitions of Vehicle Code Section 27156.
5. No claim of any kind, such as "Approved by the Air Resources Board" may be made with respect to the action taken in any advertising or other oral or written communication.

Violation of any of the above conditions shall be grounds for revocation of this order. The order may be revoked only after a ten-day written notice of intention to revoke the order, in which period the holder of the order may request in writing a hearing to contest the proposed revocation. If a hearing is requested, it shall be held within ten days of receipt of the request and the order may not be revoked until a determination after hearing that grounds for revocation exist.

The Bureau of Automotive Repair will be notified by copy of this order.

Executed at El Monte, California, this 24<sup>th</sup> day of March 1998.

  
R. B. Summerfield, Chief  
Mobile Source Operations Division

State of California  
AIR RESOURCES BOARD

EVALUATION OF FURUTANI TECHNICAL LABORATORY CO., LTD.'S  
ION TECHNO SHEET/TECHNO FUEL PIPE DEVICE FOR  
EXEMPTION FROM THE PROHIBITIONS OF VEHICLE CODE SECTION  
27156 IN ACCORDANCE WITH SECTION 2222, TITLE 13, OF THE  
CALIFORNIA CODE OF REGULATIONS

March, 1998

State of California  
AIR RESOURCES BOARD

EVALUATION OF FURUTANI TECHNICAL LABORATORY CO., LTD'S  
ION TECHNO SHEET/TECHNO FUEL PIPE DEVICE FOR  
EXEMPTION FROM THE PROHIBITIONS OF VEHICLE CODE SECTION  
27156 IN ACCORDANCE WITH SECTION 2222, TITLE 13, OF THE  
CALIFORNIA CODE OF REGULATIONS

by

Mobile Source Operations Division

9528 Telstar Avenue  
El Monte, CA 91734-8001

(This report has been reviewed by the staff of the California Air Resources Board and approved for publication. Approval does not signify that the contents necessarily reflect the views and policies of the Air Resources Board, nor does mention of trade names or commercial products constitute endorsement or recommendation for use.)

## SUMMARY

Furutani Technical Laboratory Co., Ltd., of 3-3-3, Nishi Yomeshima-cho, Matsue 690 Japan, has applied for exemption from the prohibitions in Section 27156 of the California Vehicle Code (VC) for the Ion Techno Sheet/Techno Fuel Pipe. The device is designed for installation on 1997 and older model-year gasoline and diesel powered vehicles, excluding those vehicles subject to Ultra-Low Emission Vehicle (ULEV), Low Emission Vehicle (LEV) and Transitional Low Emission Vehicle (TLEV) standards or enhanced evaporative emission standards.

Test results conducted at an independent laboratory showed that the device met the requirements under California procedures for VC Section 27156 exemption of add-on and modified parts.

Based on the submitted emissions test data, the staff concludes that the Ion Techno Sheet/Techno Fuel Pipe will not adversely affect exhaust emissions from vehicles for which the exemption is requested.

The staff recommends that Furutani Technical Laboratory Co., Ltd. be granted an exemption as requested and that Executive Order D-447 be issued.

## TABLE OF CONTENTS

	Page Number
SUMMARY	i
CONTENTS	ii
I. INTRODUCTION	1
II. CONCLUSION	1
III. RECOMMENDATION	2
IV. DEVICE DESCRIPTION	2
V. DISCUSSION	3
APPENDIX	5
INSTALLATION INSTRUCTIONS	



EVALUATION OF FURUTANI TECHNICAL LABORATORY CO., LTD.'S  
ION TECHNO SHEET/TECHNO FUEL PIPE DEVICE FOR EXEMPTION  
FROM THE PROHIBITIONS OF VEHICLE CODE SECTION 27156 IN  
ACCORDANCE WITH SECTION 2222, TITLE 13, OF THE CALIFORNIA  
CODE OF REGULATIONS

I. INTRODUCTION

Furutani Technical Laboratory Co., Ltd. (Furutani) of 3-3-3, Nishi Yomeshima-cho, Matsue 690 Japan, has applied for an exemption from the prohibitions of Vehicle Code Section (VC) 27156 for the Ion Techno Sheet/Techno Fuel Pipe device, which is designed for installation on 1997 and older model-year gasoline and diesel powered vehicles, excluding those vehicles subject to Ultra-Low Emission Vehicle (ULEV), Low Emission Vehicle (LEV) and Transitional Low Emission Vehicle (TLEV) standards and enhanced evaporative emission standards.

II. CONCLUSIONS

Based on comparative emissions testing conducted at Automobile Club of Southern California (ACSC) laboratory, Los Angeles, California, the staff concludes that Furutani's Ion Techno Sheet/Techno Fuel Pipe will not adversely affect exhaust emissions from the vehicles for which the exemption is requested.

### III. RECOMMENDATION

The staff recommends that Furutani Technical Laboratory Co., Ltd. be granted an exemption for their Ion Techno Sheet/Techno Fuel Pipe for installation on 1997 and older model-year gasoline and diesel powered vehicles, excluding those vehicles subject to Ultra-Low Emission Vehicle (ULEV), Low Emission Vehicle (LEV), Transitional Low Emission Vehicle (TLEV) standards or enhanced evaporative emission standards. The staff also recommends that Executive Order D-447 be issued.

### IV. DEVICE DESCRIPTION

The Ion Techno Sheet/Techno Fuel Pipe is designed to fit in the air filter housing and on the fuel line respectively. The Techno Sheet has a compound (Thorium Oxide) that is melted into the base metal sheet. According to the manufacturer, the Techno Sheet is cut to size (depending on the design of the air cleaner housing) and attached to the inside of the air cleaner housing by means of double-faced adhesive tape. The Techno Fuel Pipe also contains the Thorium Oxide compound which is housed in a stainless steel/copper cylindrical shaped unit. The device also contains small ceramic pellets which the manufacturer claims

interact with the Thorium Oxide creating a better ionization of the fuel as it passes through the device. The Techno Fuel Pipe comes in two different sizes; the engine displacement determines the correct size to be used. The device is narrowed at both ends in order to match the fuel line and is attached to the vehicle's fuel line by the use of two clamps. The device's installation instructions are shown in the Appendix.

V. DISCUSSION

Furutani claims that using their device will decrease exhaust emissions and improve fuel economy. Furutani submitted data from testing conducted at ACSC laboratory in Los Angeles, California. Comparative emissions tests (stock vs modified) were conducted on two California certified vehicles: a 1997 1.6L Honda Civic and a 1997 4.6L Ford F-150 Pickup truck. Data from the tests are shown below.

Automobile Club of Southern California  
Los Angeles, California

1.6L Honda Civic

	<u>HC</u>	<u>CO</u>	<u>NOx</u>
Baseline (g/mi)	0.122	1.792	0.071
Device (g/mi)	0.146	1.823	0.070
Change (g/mi)	+0.024	+0.031	-0.001
Percent Change	+19.67	+1.73	-1.41

4.6L Ford F150 Pickup Truck

	<u>HC</u>	<u>CO</u>	<u>NOx</u>
Baseline (g/mi)	0.161	1.975	0.083
Device (g/mi)	0.154	1.929	0.075
Change (g/mi)	-0.007	-0.046	-0.008
Percent Change	-4.35	-2.23	-9.64

The emission increases shown on the above test results are within the acceptable limits as specified in the "Procedures for Exemption of Add-on and Modified Parts."

The ARB did not perform testing to confirm the emission test results submitted by the applicant; however, ARB staff evaluated the impact of the Ion Techno Sheet/Techno Fuel Pipe on the On-Board Diagnostic II (OBD II) system. Scan tool testing confirmed that the device did not affect the vehicle's ability to perform OBD II system operation.

Staff concludes that the installation of the Ion Techno Sheet/Techno Fuel Pipe will not have an adverse effect on exhaust emissions from vehicles for which the exemption is requested. Furutani Technical Laboratory Co., Ltd. has submitted all the required information and fulfilled the requirements for exemption.

APPENDIX

# INSTALLATION MANUAL

**IONTECHNO SHEET and FUEL PIPE must installed by authorized dealers only.**

## INSTALLATION of IONTECHNO SHEET

1. Stop the engine before install the Iontechno Sheet.
2. Take the lid off the canister of the air cleaner.
3. Take out the air filter component.
4. Clean inside of canister completely. Make sure dust and oil are removed.
5. Cut the Iontechno Sheet to the size of inner part of the air cleaner canister. (picture A)
6. Attach them inside wall of canister with the double-faces adhesive tape. (picture B)  
Check the tape for the perfect attachment. (picture B)  
Use rivet to attach the sheet for a large size air filter canister.
7. Put the air filter back and cover the lid.

(picture A)

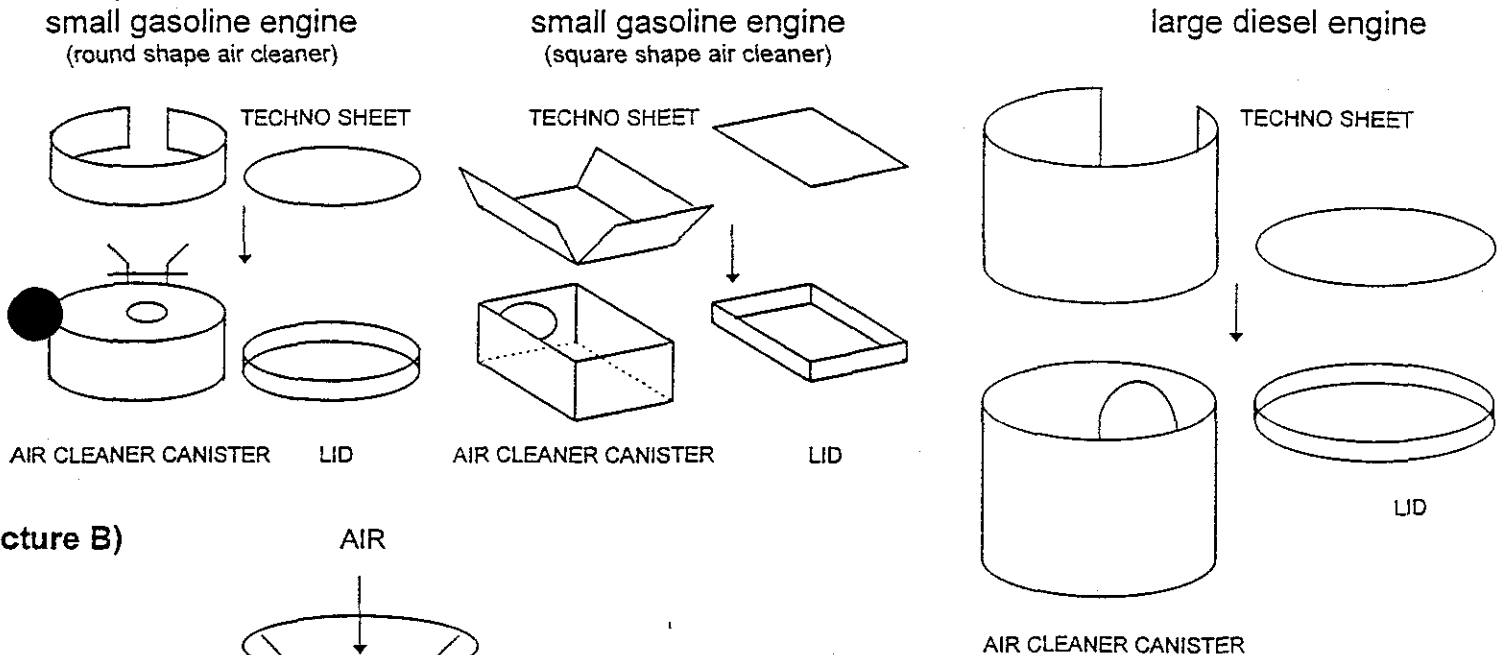

(picture B)

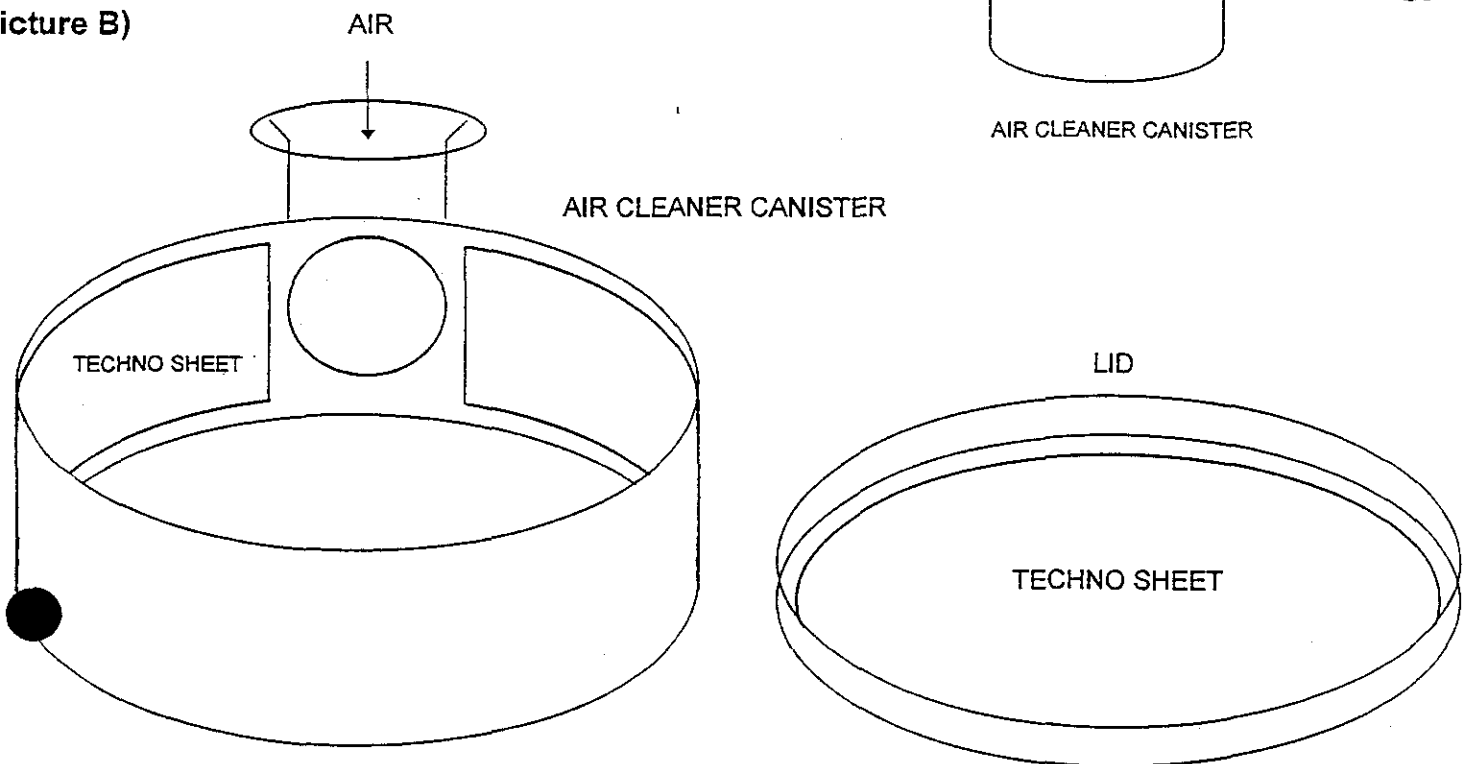

## INSTALLATION of IONTECHNO FUEL PIPE

### DO NOT INSTALL FUEL PIPE WHILE ENGINE IS HOT

1. Stop the engine before the installation of the IONTECHNO FUEL PIPE.  
(Start installation after the engine is cool down.)
2. Choose the place where the IONTECHNO FUEL PIPE is placed. Usually, it is best to install it close to the fuel injection or the carburetor in engine room.
3. Before cut a fuel line, use locking clamp on the both side of cut off position. This will prevent from excessive amount of fuel flash out from fuel line.
4. Install IONTECHNO FUEL PIPE, then use round clamp to tighten up both side of fuel pipe.  
(picture C & D)

(picture C)

CORRECT

INCORRECT

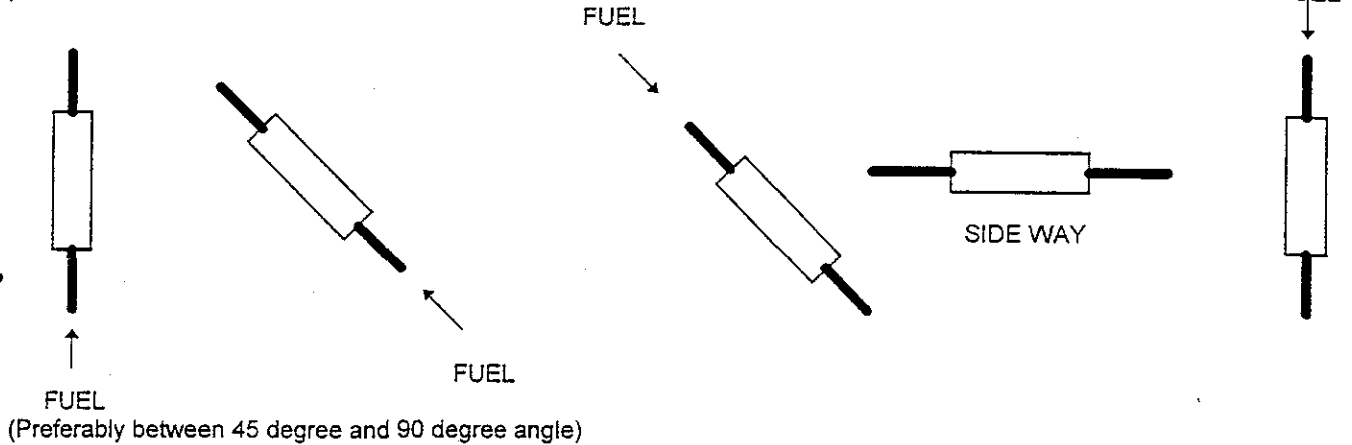

(picture D)

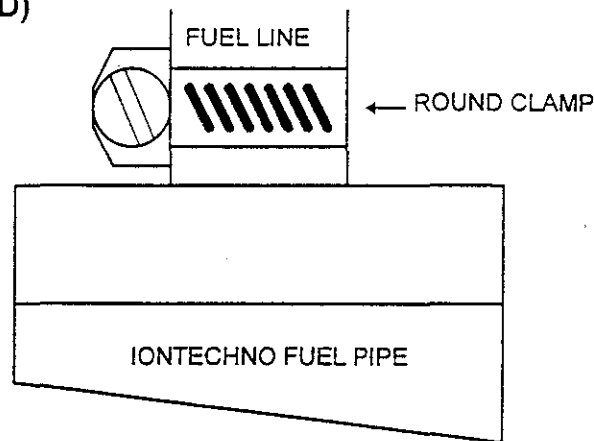

5. Tied IONTECHNO FUEL PIPE to any part of engine room where does not interfere the operation of the vehicle. (picture E)

(picture E)

