

State of California
AIR RESOURCES BOARD

EXECUTIVE ORDER D-49
Relating to Exemptions under Section 27156
of the Vehicle Code

SEARS, ROEBUCK AND CO.
"SEARS PENSKE CAPACITIVE DISCHARGE ELECTRONIC IGNITION SYSTEM, NO. 8205"
"SEARS PENSKE BREAKERLESS CONVERSION KIT, NO. 8206"

Pursuant to the authority vested in the Air Resources Board by Section 27156 of the Vehicle Code; and

Pursuant to the authority vested in the undersigned by Section 39023 of the Health and Safety Code;

IT IS ORDERED AND RESOLVED: That the installation of the "Sears Penske Capacitive Discharge Electronic Ignition System, No. 8205" and "Sears Penske Breakerless Conversion Kit, No. 8206" systems manufactured by Auto Start/Systematic, Inc., 547 North Wheeler Street, Saint Paul, Minnesota 55014 and marketed by Sears, Roebuck and Co., Pacific Coast Buying Office, Dept. 733 P.C.B., 900 South Fremont Avenue, Alhambra, California 91802, having been found to not reduce the effectiveness of the required motor vehicle pollution control devices and therefore, are exempt from the prohibitions of Section 27156 of the Vehicle Code for the following applications :

- (1) The "Sears Penske Capacitive Discharge Electronic Ignition System, No. 8205" can be installed on all 1974 and older model-year vehicles except those vehicles originally equipped with a breakerless or electronic ignition system.
- (2) The "Sears Penske Breakerless Conversion Kit No. 8206" can be installed on all 1974 and older model-year Ford and General Motors Corporation vehicles equipped with 8 cylinder engines except those vehicles originally equipped with a breakerless or electronic ignition system.

The electronic circuit of the 8205 system consists of a power transformer, capacitors, resistors, diodes and a silicon controlled rectifier. The 8206 system consists of a magnetic pick-up unit, E.D.M. module, and the 8205 system.

This Executive Order is valid provided that installation instructions for this device will not recommend tuning the vehicle to specifications different than those listed by the vehicle manufacturer.

Changes made to the design or operating conditions of the device as originally submitted to the Air Resources Board for evaluation that adversely affect the performance of the vehicle's pollution control devices shall invalidate this Executive Order.

"SEARS PENSKE CAPACITIVE DISCHARGE ELECTRONIC IGNITION SYSTEM, NO. 8205

"SEARS PENSKE BREAKERLESS CONVERSION KIT, NO. 8206"

EXECUTIVE ORDER D-49

Marketing of this device using an identification other than that shown in this Executive Order or marketing of this device for an application other than those listed in this Executive Order shall be prohibited unless prior approval is obtained from the Air Resources Board.

This Executive Order does not constitute any opinion as to the effect that the use of this device may have on any warranty either expressed or implied by the vehicle manufacturer.

THIS EXECUTIVE ORDER DOES NOT CONSTITUTE A CERTIFICATION, ACCREDITATION, APPROVAL, OR ANY OTHER TYPE OF ENDORSEMENT BY THE AIR RESOURCES BOARD OF ANY CLAIMS OF THE APPLICANT CONCERNING ANTI-POLLUTION BENEFITS OR ANY ALLEGED BENEFITS OF THE "SEARS PENSKE CAPACITIVE DISCHARGE ELECTRONIC IGNITION SYSTEM, NO. 8205 AND SEARS PENSKE BREAKERLESS CONVERSION KIT, NO. 8206" DEVICES.

No claim of any kind, such as "Approved by Air Resources Board" may be made with respect to the action taken herein in any advertising or other oral or written communication.

Section 17500 of the Business and Professions Code makes unlawful, untrue or misleading advertising, and Section 17534 makes violation punishable as a misdemeanor.

Sections 39130 and 39184 of the Health and Safety Code provide as follows:

"39130. No person shall install, sell, offer for sale, or advertise, or, except in an application to the board for certification of a device, represent, any device as a motor vehicle pollution control device unless that device has been certified by the board. No person shall sell, offer for sale, advertise, or represent any motor vehicle pollution control device as a certified device which, in fact, is not a certified device. Any violation of this section is a misdemeanor."

"39184. (a) No person shall install, sell, offer for sale, or advertise, or, except in an application to the board for accreditation of a device, represent, any device as a motor vehicle pollution control device for use on any used motor vehicle unless that device has been accredited by the board. No person shall sell, offer for sale, advertise, or represent any motor vehicle pollution control device as an accredited device which, in fact, is not an accredited device. Any violation of this subdivision is a misdemeanor."

Any apparent violation of the conditions of this Executive Order will be submitted to the Attorney General of California for such action as he deems advisable.

Executed at Sacramento, California, this 20th day of February, 1975.

WILLIAM SIMMONS
Executive Officer

State of California

AIR RESOURCES BOARD

Staff Report

January 28, 1975

Evaluation of the Sears, Roebuck and Co., "Sears Penske Capacitive Discharge Electronic Ignition System, No. 8205" and "Sears Penske Breakerless Conversion Kit, No. 8206" for Compliance with the Requirements of Section 27156 of the California Motor Vehicle Code

I. Introduction

Sears, Roebuck and Co., Pacific Coast Buying Office, Dept. 733 P.C.B., 900 South Fremont Avenue, Alhambra, California 91802 has submitted an application requesting an exemption from the prohibitions of Section 27156 of the motor vehicle code for the "Sears Penske Capacitive Discharge Electronic Ignition System, No. 8205" and "Sears Penske Breakerless Conversion Kit, No. 8206" (Reference Exhibit A). Vehicle Code Section 27156 prohibits the installation of any device or mechanism which reduces the effectiveness of the emission control system. The Air Resources Board has been granted the authority under this vehicle code section to exempt devices from this prohibition if a finding shows the device does not reduce the effectiveness or performance of the emission control system. The applicant is requesting the installation of the 8205 system on all 1974 and older model-year vehicles equipped with conventional point system and the 8206 system on 1974 and older model-year Ford and General Motor Corporation vehicles equipped with an eight cylinder engine and a breakerpoint type distributor.

January 28, 1975

II. System Description

The 8205 system is a capacitive discharge system which is installed into the ignition system. The 8206 system replaces the breaker-points with a magnetic pick-up unit and requires the use of an E.D.M. module and the 8205 system. Both systems are manufactured for Sears, Roebuck Co. by Auto Start/Systematics, Inc., 547 North Wheeler Street, Saint Paul, Minnesota 55104. Exhibit B shows the electrical schematic and installation instructions for the device.

The 8205 system consists of the triggering, energy transfer, storage and discharge circuits. After the discharge circuit is activated, saturation of the transformer within the C. D. unit is accomplished. This energy is transferred from the transformer secondary through two rectifiers to a storage capacitor. The storage and discharge circuit releases this energy to the primary side of the ignition coil. When the distributor points open, this causes the silicon controlled rectifier to stop current flow to the ignition coil which causes the spark plug to fire.

For the 8206 system a magnetic-pick-up is mounted in place of the distributor points. This unit consists of a coil core and a permanent magnet. The coil core is placed near the existing distributor cam lobe. When the high point of the cam moves passed the coil core, a signal is generated which is transferred to the E.D.M. module. The module amplifies and filters the signal by producing

January 28, 1975

a square-wave signal which is identical to the signal caused by point opening. This square-wave signal is sent to the triggering circuit of the capacitive discharge system.

- According to the applicant, these systems are designed to reduce servicing of the ignition system by decreasing the number of tuneups.

III. System Evaluation

The Air Resources Board staff's evaluation of these two devices was based on a consideration of the method used to mount the magnetic-pick-up unit and the electrical output of the devices.

The vehicles used in this test program are described below:

Vehicle I

Make and Model-Year	1974 American Motors Ambassador Station Wagon
Engine	360 Cubic Inch Displacement
Carburetor	Two Barrel
Transmission	Automatic
Emission Control System	AI-EGR-EM

Vehicle II

Make and Model-Year	1974 Pontiac Grand Prix
Engine	400 Cubic Inch Displacement
Carburetor	Four Barrel
Transmission	Automatic
Emission Control System	EM-EGR

January 28, 1975

Since the magnetic pick-up unit used on the GM Delco distributor application is held down by two cotter pins, it was necessary to determine if this installation was adequate to prevent lateral movement of the magnetic pick-up unit. The device was installed on the Pontiac per the installation instructions. This vehicle was driven several times on the dynamometer using the Hot CVS-1 driving procedure. After completion of the testing, a feeler gauge was used to measure the gap between the cam lobe and the magnetic pick-up. The magnetic pick-up did not move during the test.

The next set of tests consists of measuring the electrical output of the device. The following table summarizes the results of the baseline, No. 8205 and No. 8206 systems.

Centrifugal Spark Advance

(Crankshaft Degrees)

Engine RPM	<u>1974 Pontiac</u>			<u>1974 Ambassador</u>		
	<u>Baseline</u>	<u>8205</u>	<u>8206</u>	<u>Baseline</u>	<u>8205</u>	<u>8206</u>
Idle	0	0	0	0	0	0
1000	0	0	0	6	5	5
1500	8	8	8	13	13	13
2000	11	12	12	15	15	15
2500	13	14	14	18	18	18
3000	16	16	16	21	20	20

Evaluation of the Sears, Roebuck and Co., "Sears Penske Capacitive Discharge Electronic Ignition System, No. 8205" and "Sears Penske Breakerless Conversion Kit, No. 8206" for Compliance with the Requirements of Section 27156 of the California Motor Vehicle Code

January 28, 1975

Vacuum Spark Advance
(Crankshaft Degrees)

<u>Vacuum (in Hg.)</u>	<u>1974 Pontiac</u>			<u>1974 Ambassador</u>		
	<u>Baseline</u>	<u>8205</u>	<u>8206</u>	<u>Baseline</u>	<u>8205</u>	<u>8206</u>
0	0	0	0	0	0	0
5	0	0	0	2	2	2
10	2	2	2	12	12	12
15	17	17	17	15	15	15
20	19	19	19	15	15	15

Spark Duration
(Microseconds)

<u>Engine RPM</u>	<u>1974 Pontiac</u>			<u>1974 Ambassador</u>		
	<u>Baseline</u>	<u>8205</u>	<u>8206</u>	<u>Baseline</u>	<u>8205</u>	<u>8206</u>
0	1200	230	230	1300	220	220
1200	1200	230	230	1200	220	220
2000	1200	230	230	1200	220	220
3000	1200	230	230	900	220	220

Rise Time
(Microseconds)

<u>Engine RPM</u>	<u>1974 Pontiac</u>			<u>1974 Ambassador</u>		
	<u>Baseline</u>	<u>8205</u>	<u>8206</u>	<u>Baseline</u>	<u>8205</u>	<u>8206</u>
Idle	60	25	25	50	30	30
1200	60	25	25	50	30	30
2000	60	25	25	50	30	30
3000	60	25	25	50	30	30

Evaluation of the Sears, Roebuck and Co., "Sears Penske Capacitive Discharge Electronic Ignition System, No. 8205" and "Sears Penske Breakerless Conversion Kit, No. 8206" for Compliance with the Requirements of Section 27156 of the California Motor Vehicle Code

January 28, 1975

Secondary Voltage Available

(Kilo volts)

<u>Engine RPM</u>	<u>1974 Pontiac</u>			<u>1974 Ambassador</u>		
	<u>Baseline</u>	<u>8205*</u>	<u>8206*</u>	<u>Baseline</u>	<u>8205</u>	<u>8206</u>
Idle	28	40	40	29	30	31
1200	28	40	40	30	31	31
2000	30	40	40	31	32	32
3000	25	40	40	29	31	31

*Data questionable, reading too high maybe due to reading errors or malfunctioning oscilloscope.

Secondary Voltage Required

(Kilo volts)

<u>Engine RPM</u>	<u>1974 Pontiac</u>			<u>1974 Ambassador</u>		
	<u>Baseline</u>	<u>8205</u>	<u>8206</u>	<u>Baseline</u>	<u>8205</u>	<u>8206</u>
Idle	14	14	14	14	12	12
1200	15	14	14	14	13	13
2000	10	10	10	13	10	10
3000	9	9	9	11	10	10

The above results generally show changes in spark duration, rise time, and secondary available voltages when the device tests are compared to baseline. The 7% increase in available voltage is within a range not considered detrimental to the O.E.M. ignition system. Likewise the reduction in spark duration to 220 u sec. is not expected to cause a measurable affect on exhaust emissions. The increase in rise rate and voltage level generally means a higher intensity spark will be produced. The above results indicate the installation of the 8205 or 8206 systems would not have any significant effect on the emission control system.

January 28, 1975

IV. Conclusion and Recommendation

The staff believes the installation of these two devices would not reduce the effectiveness of the emission control system.

Therefore, the staff recommends that Sears, Roebuck and Co. be granted an exemption from the prohibitions of Section 27156 for the Sears Penske Capacitive Discharge Electronic Ignition Unit, No. 8205 and Sears Penske Breakerless Conversion Kit, No. 8206 for the following applications:

1. The "Sears Penske Capacitive Discharge Electronic Ignition system No. 8205" can be installed on all 1974 and older model-year vehicles except those vehicles originally equipped with breakerless or electronic ignition system.
2. The "Sears Penske Breakerless Conversion Kit No. 8206" can be installed on 1974 and older model-year Ford Motors and General Motors Corporations vehicles equipped with eight cylinder engines except those vehicles originally equipped with breakerless or electronic ignition system.

Exhibit A

Application

Sears, Roebuck and Co.

PACIFIC COAST BUYING OFFICE

900 SOUTH FREMONT AVENUE

ALHAMBRA, CALIFORNIA 91802

Dept 733PCB

November 18, 1974

Mr. Robert Weis
California State Air Resource Board
9528 Telstar
El Monte, California 91731

Dear Mr. Weis:

Enclosed are completed application forms, Owner's Manual and write-up covering the Sears #8205 Capacitive Discharge Electronic Ignition Unit and #8206 Breakerless Conversion Kit.

Along with these papers are samples of the two items for your evaluation and testing. If you need anything else to complete your evaluation, please call me at (213) 576-4186.

If you have any technical questions regarding these units, please contact Andy Kuehn at Systematics Inc., 547 North Wheeler Street, St. Paul, Minnesota 55104. His phone number is (612) 645-5529.

I would greatly appreciate your help in getting these items tested and approval granted as quickly as possible. They have been pulled off sale from our catalogs and retail stores and we are anxious to resume sales. We were unfortunately lead to believe by someone in another department of the California State Government that no approval was needed on products of this type.

Very truly yours,



Chuck Hattersley

CH:adm

cc: Kinglsey Macomber, Air Resources Board
Andrew Kuehn, Systematics, Inc.
Roger Stam, D/628
D. J. Goerke, D/156-28, LACO
R. Varie, D/733PCB

TOOLS NEEDED:

STEP I CAPACITIVE DISCHARGE

IGNITION:

- Screw Driver
- Drill with 9/64" bit
- 3/8" Hex and 11/32 Hex Nut Driver or
- Pliers for coil terminals
- Pliers for battery cable
- Wrench as required for battery terminals.

INSTALL STEP I SYSTEM

NOTE:

- A. *The CAPACITIVE DISCHARGE IGNITION can be used only on a 12 volt negative ground electrical system. Observe battery polarity to prevent damage to this system.*
- B. *If both STEP I CAPACITIVE DISCHARGE UNIT and STEP II BREAKERLESS CONVERSION KIT are to be installed together, it is recommended first install the STEP I unit fully, and test system with conventional points before installing STEP II BREAKERLESS SYSTEM.*

(1) LOCATE IGNITION AMPLIFIER.

Locate mounting area near front end of engine well, preferably on front cross-member to one side of radiator, or on side of engine well—locate on metal surface if possible.

Amplifier unit may be mounted in front of radiator if wire cable is fully protected in passing through front panels of engine well. (Never cut and splice cabling).

Always mount unit where air can flow to the unit.

Locate position so that wires will be near bottom of unit.

Use Amplifier as template, mark location for three screws.

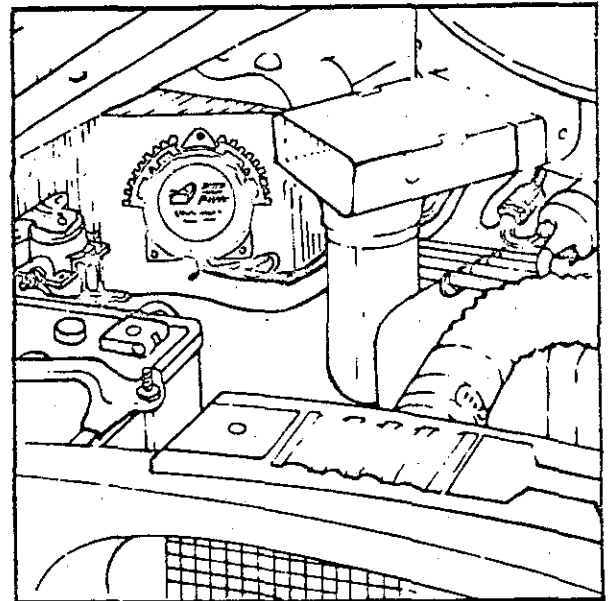
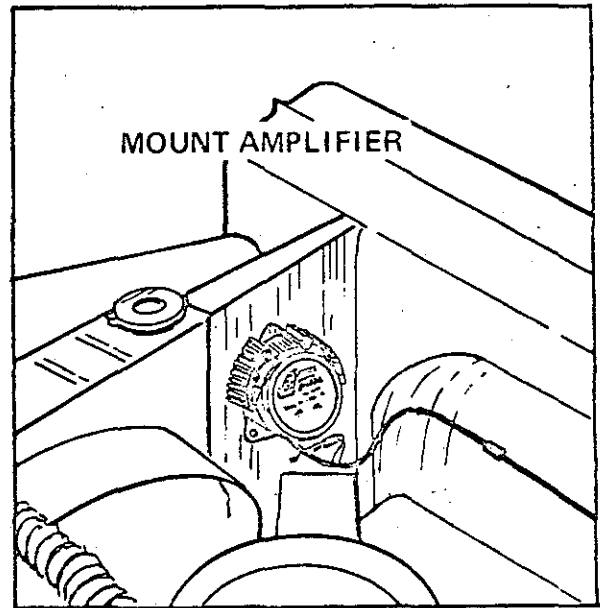

(2) MOUNT AMPLIFIER.

Drill three 9/64" holes. Mount with self-tap screws provided. Do not distort base; partially flatten mounting area if steeply curved.

(3) ROUTE CABLE TO COIL.

Route along existing cabling if possible; protect from sharp surfaces or objects. Do not cut this cable (coil up excess wire near Amplifier if necessary).

Keep wires away from hot manifold.
Keep cables away from moving linkages.

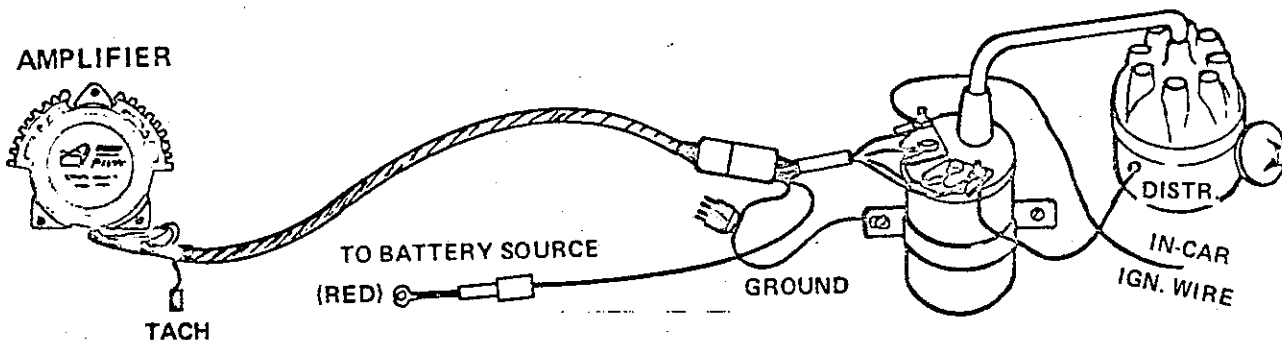

(4) FASTEN WIRES TO COIL.

(a) Remove wires from POS. (+ or BAT) terminal of coil. Fasten Retainer with WHITE wire terminal to POS. (+ or BAT) post on coil. Screw down firmly. Be sure condenser wire is removed from coil.

(b) Fasten in-car wire (removed from POS. post including exposed condenser wire if used) to Orange wire screw on Retainer. Tighten securely. **NOTE: DO NOT connect any condenser wire to coil POS. (+ or BAT) post.**

(c) Remove wire from NEG. (- or DIST) terminal of coil. Fasten Retainer with GREEN wire terminal to NEG. (- or DIST) post on coil. Screw down firmly.

(d) Fasten in-car wire (removed from NEG. (- or DIST) post of the coil) to BLUE wire screw on Retainer. Tighten securely.

NOTE: If the coil position causes Coil Harness or Retainer to press against nearby obstructions, loosen coil bracket and rotate coil. Retighten coil bracket.

Retainer screws **MUST** always point outward, away from top of coil.

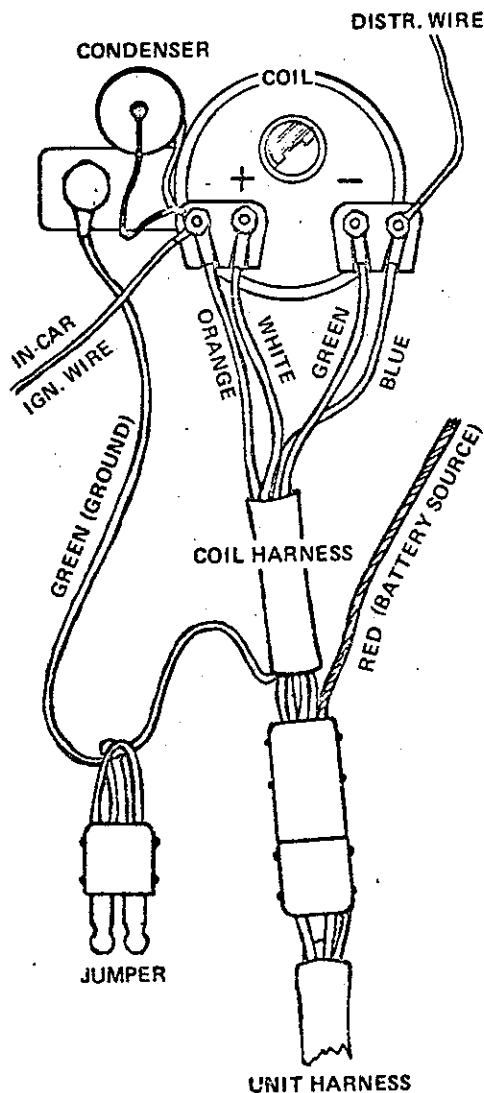

NOTE ON FORD IGNITION: Ford coil connections may be push-on connections. These connectors may be pressed onto the BLUE and ORANGE wire screws on the Retainers. Use 10-32 nut and #10 lockwasher on coil terminals.

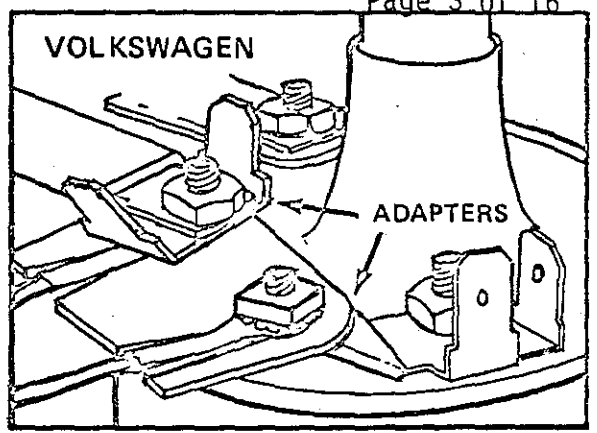
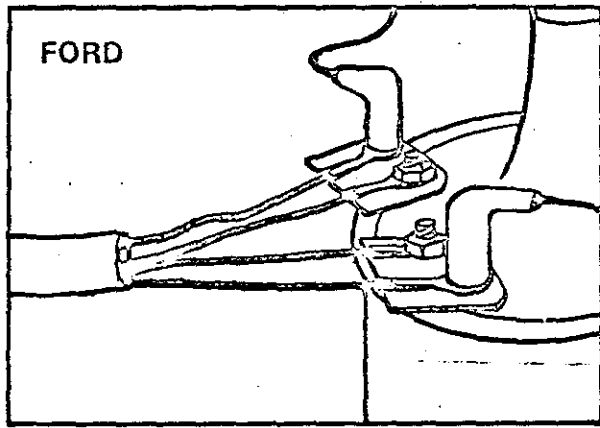

NOTE ON VOLKSWAGEN IGNITION: VW coil terminals usually have blade terminals. Add Adapters to Retainer; use 6-32 screw set to mount female adapter to White and Green eyelets. Mount male blade adapters to Blue and Orange wire screws. Plug Retainers to coil blades; plug in-car wires to adapters on Retainers. Be sure **NO** in-car wire is left on coil blade.

(5) ROUTE RED WIRE TO A BATTERY SOURCE.

Route Red wire to a battery source nearest to battery. Here are some suggestions:

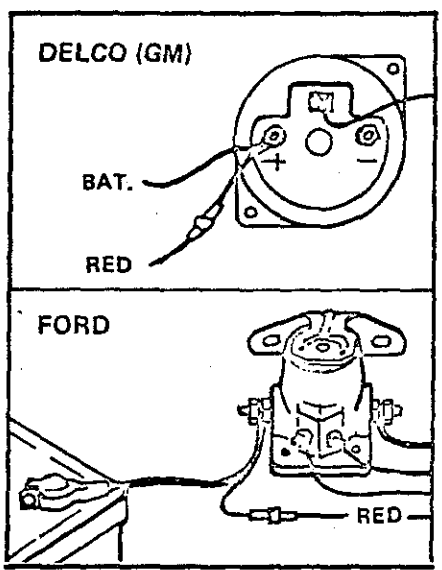

Volkswagen Cars:

Red wire may be attached to Orange wire screw on Retainer when mounting Adapters. Higher output is available if Red wire is attached to battery circuit at Voltage Regulator or other direct battery source.

General Motors Cars:

Use battery post on fender, if available, or Use battery post on horn relay, or Use output terminal on Alternator.

Ford Motor Cars:

Use battery post on starter (solenoid) relay (this has heavy wire going directly to POS. (+) post of battery).

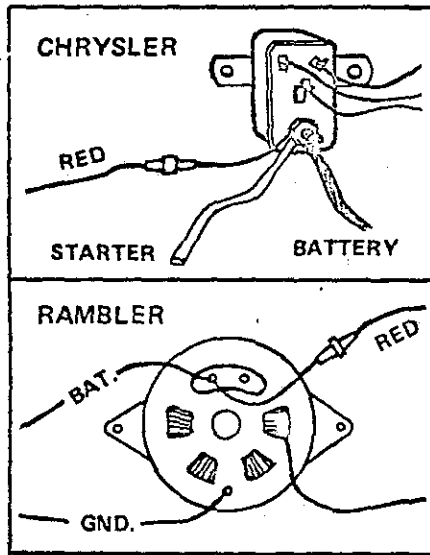

Chrysler Motor Cars:

Use battery post on starter relay. (This is large post with battery wire).

Rambler Cars:

Use battery output on terminal on Alternator, or

Use "B" terminal on Voltage Regulator with generator-equipped cars.

Other Engines:

Follow applicable suggestions noted above.

(6) FASTEN RED WIRE.

Remove one wire terminal from battery.

Carefully route Red wire through existing cable loops if possible. Be sure that wire is protected from sharp surfaces and is held away from hot exhaust manifold.

Do not press wire against any sharp metal surface. Choose short wire harness that has proper terminal for connection to battery source (one has 1/4" ring terminal, the other has 5/16" or 3/8" ring terminal).

Remove nut from battery source. Place on short wire. Replace nut and tighten securely.

Thread short wire through any protective (rubber) cover that covers battery source connection.

Push onto Red wire. Be sure blade and plug mesh fully.

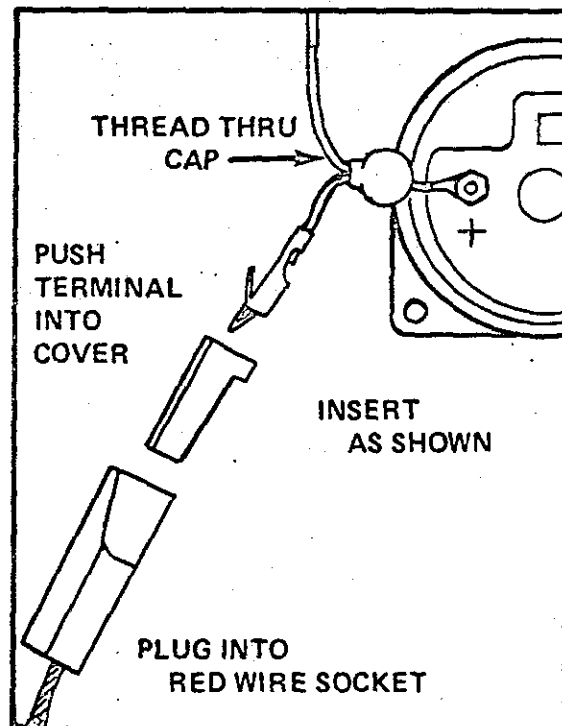

(7) ATTACH GROUND WIRE.

Ground wire is Green wire with ring terminal. Route this terminal to a convenient screw or bolt on the engine block; preferred location is to the bracket at the coil or to a bolt on engine for grounding strap to the firewall.

Loosen bolt or screw, insert ground terminal, retighten securely.

If terminal is too large for screw, snip open end of terminal and squeeze together with pliers before inserting under screw.

NOTE: DO NOT place the ground terminal under a screw for cylinder cover, carburetor, or any bolt that is normally removed for maintenance. Volkswagen—Attach Green wire to bolt on engine block; do not ground to shroud holding coil.

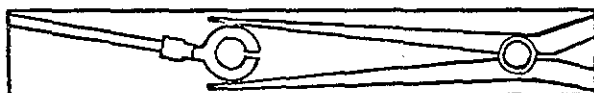
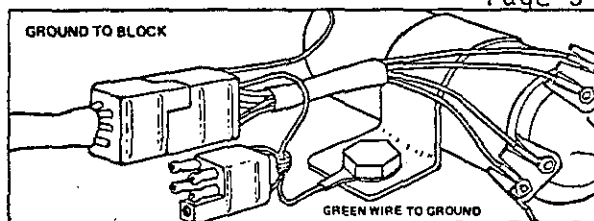
**(8) CHECK WIRING.**

Trace all wires and compare to wiring schematic.

Tape back all wires and cables from hot manifold and sharp edges.

Do not route wires or cables near or over any moving linkages!

For high RPM operation (Racing), tie back all wires and cables securely to prevent wire breakage.

Use wire ties provided to hold wires in place.

Be sure no connector touches any exposed surfaces; tape connections if necessary.

Be sure battery wire connector does not touch ground.

Be sure there is no connection to coil POS. (+ or BAT) terminal except White wire of cable.

When visual check is completed, restore battery cable to battery post.

(9) TEST IGNITION SYSTEM.

- (a) Turn on ignition switch to "Start".
If engine does not fire as it would normally, turn off and recheck wiring
- (b) Check out ignition bypass.
Disconnect cable at connector near Ignition Coil.
Push Jumper Plug into Coil Harness Socket.

NOTE: Red wire to battery is automatically removed for conventional ignition operation.

- (c) Restore Ignition Amplifier: Reverse procedure in (B) above.

NOTE: Use Ignition Bypass whenever it is desired to operate with Conventional Ignition. Always use conventional ignition when tuning engine unless timing light and meters are protected from high discharge of this system.

Ignition Bypass cannot be used with STEP II BREAKERLESS IGNITION.

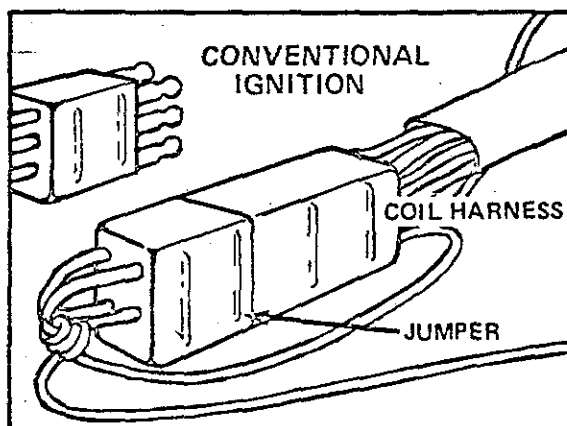
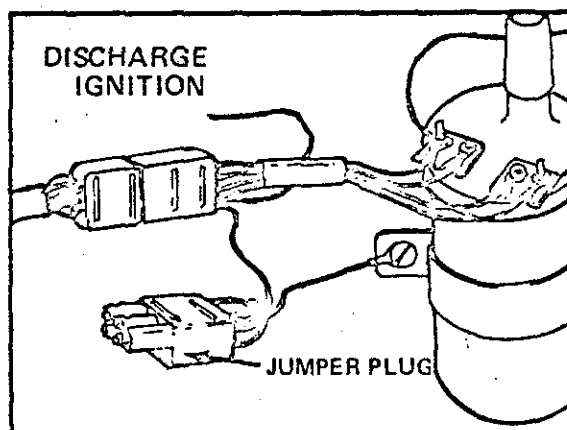

INSTALLATION

TOOLS NEEDED:

- Screwdriver
- Wrench as required for distributor hold-down clamp.

INSTALL STEP II BREAKERLESS CONVERSION KIT

NOTE:

- (A) Always install and test STEP I before installing the breakerless components.
- (B) The Magnetic Pick-Up Unit must be mounted in the distributor at a location that will maintain the proper alignment of the rotor electrode to the distributor cap electrodes. The coil, therefore, must be mounted at the approximate location where the breaker points were removed, but offset in a direction opposite to the direction of cam rotation. With the proper offset, the core will align with the high point of the cam where this point would be at the instant the breaker points would open.

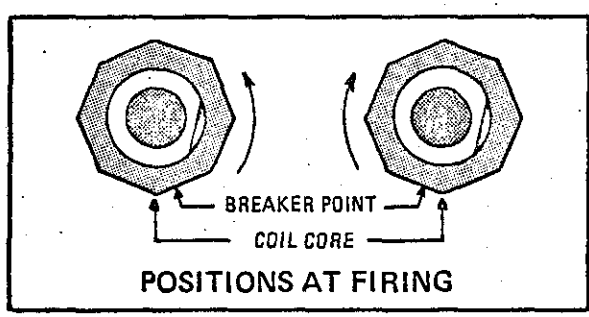

Therefore, it is important that the Magnetic Pick-Up Unit be located accurately for proper performance of the engine.

- (C) The gap between the coil core and the high point of the cam determines the sensitivity of the system. The smaller the gap, the more accurate and consistent firing at low RPM; for instance, during cranking in cold weather. The gap cannot be less than that allowed by the wear characteristics of the distributor shaft (wobble), and by the possible reduction of gap with the vacuum advance system of an eccentric advance distributor (Ford).

The coil core should never touch the distributor cam.

CAUTION:

The Magnetic Pick-Up Unit contains a powerful magnet which will attract iron objects. DO NOT set the unit near a file or on a bench where there are iron filings. Filings will readily stick to the core and cause erratic firing when mounted in distributor. If iron objects or filings stick to the Magnetic Pick-Up Unit in the distributor. A stiff, clean fiber brush is the best means of flicking off filings.

INSTALL AS FOLLOWS:

1. Remove cap from distributor and remove rotor.
2. Disconnect distributor wire from retainer at coil.
3. Remove breaker point set and condenser from distributor breaker plate.

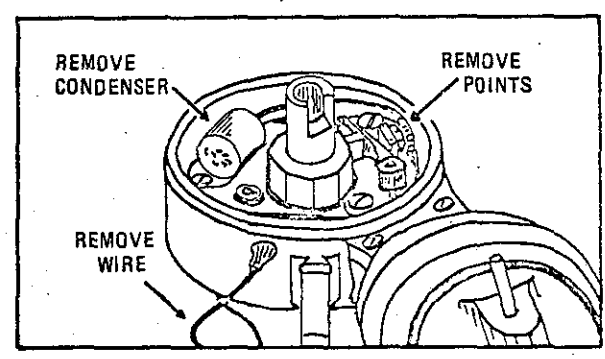

4. Use illustrations to locate Pick-Up Unit and Tie-downs. Mount Tie-downs loosely in holes shown (Note: Three sizes of Tie-down are provided; choose proper Tie-down as noted in illustrations). Be sure that screw and lockwasher are oriented with Tie-downs as follows:

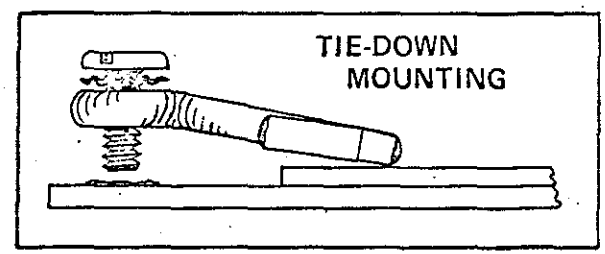

5. Mount Magnetic Pick-Up Unit in distributor:

A. Delco-Remy V-8 (General Motors, American Motors, Checker and International Harvester). Swing Tie-downs to outside. Place Magnetic Pick-Up Unit onto distributor plate by holding its base at cam level and dropping over ring on distributor plate. Rotate Pick-Up Unit until it is positioned with respect to locating pin (a locating protrusion) on distributor plate:

(1) Clockwise cam rotation distributor (Chevrolet, Buick, Cadillac) — (Vacuum advance leaves distributor case in counter clockwise direction): Rotate Pick-Up Unit until locating pin is touching outer stop on notch on Pick-Up Unit base.

(2) Counter clockwise cam rotation distributor (Oldsmobile, Pontiac) — (Vacuum advance leaves distributor case in clockwise direction): Rotate Pick-Up Unit until locating pin is snug in corner of notch near coil.

Place gap depth gauge around cam. Squeeze together to form rounded surface. Swing in Tie-downs, push base plate against ring and coil core against gap gauge, and tighten one Tie-down (it may be necessary to put pressure on Tie-down to prevent rotating out during tightening). Position and hold other Tie-down on base plate and tighten screw. Be sure base of Pick-Up Unit is flat on distributor breaker plate. Remove gauge after tightening.

NOTE: (a) Distributor wire need not be removed; but it must be taped out of the way.

(b) Route coil wires to where gap is at bottom of distributor cap when re-installed.

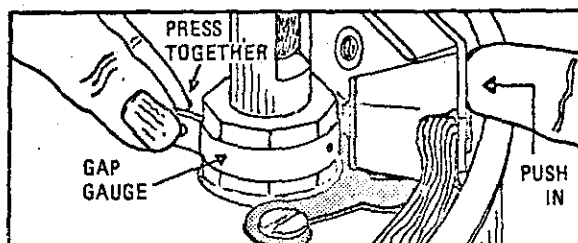
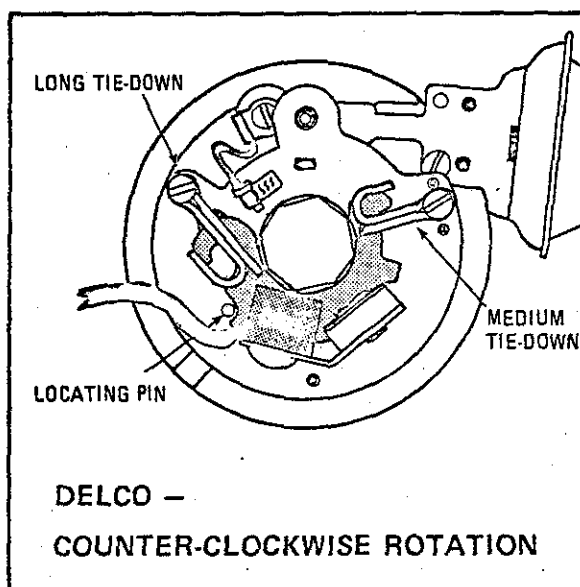
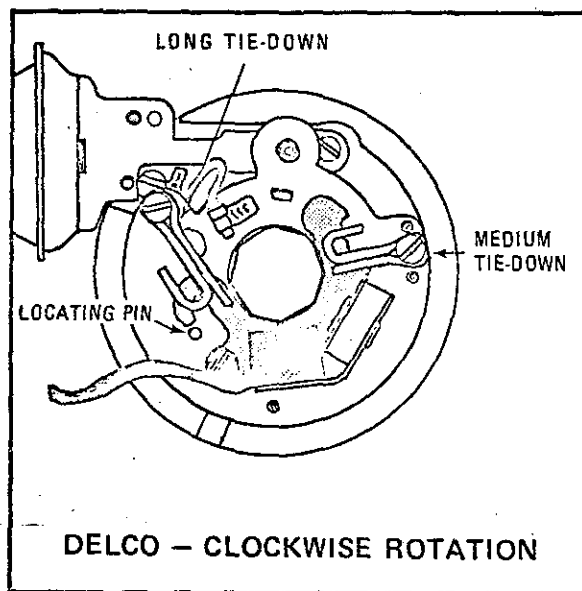

- B. Ford V-8 (Auto-Lite and Motorcraft)
—Swing long Tie-down to outside. Place Magnetic Pick-Up Unit onto distributor plate in a position aligning hook notch over screw hole on vacuum advance side. Install screw with lockwasher, but do not tighten. Place gap depth gauge around cam. Squeeze together to form rounded surface. Rotate coil inward until core coil touches gap gauge. Tighten screw. Swing in long Tie-down over base of Pick-Up Unit and tighten its screw (keep clearance between Tie-down and cam).

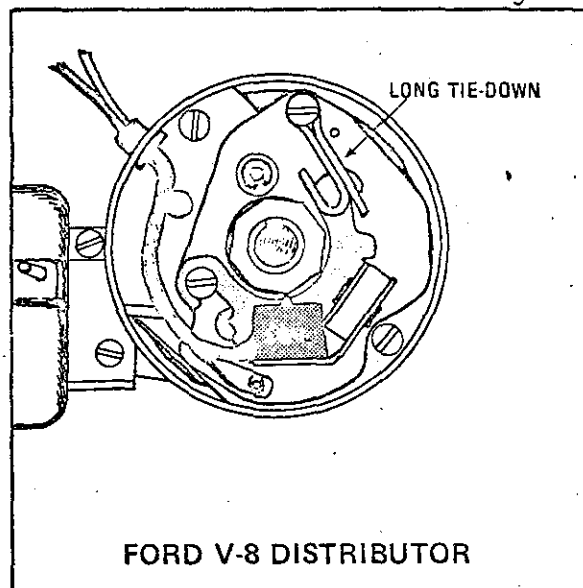

- C. Mallory—NOTE: Put Pick-Up Coil assembly on plate before mounting Tie-downs.

Remove terminal screw and insulators going through the hole in the casting. Locate coil approximately opposite to this hole. For counter-clockwise rotating cam, swing coil in counter-clockwise direction until snug to brass pins. For clockwise rotating cam, swing coil in clockwise direction until snug. Place special washer (external tooth) and stud fastener on the brass pin that is nearest the magnet. Orient the special washer to be as flat as possible. Then press down stud fastener with pliers, pushing down both sides evenly. Press down firmly. Place Tie-down over other brass pin and put in screw. Place gap gauge over cam and squeeze. Push coil core to gap gauge and tighten screw on Tie-down. If the base plate can be moved, press down on stud fastener with a screwdriver or pliers and retighten. Repeat adjustment of coil to cam. Thread wires through hole in casting. Use rubber sheeting to form grommet, wrap on wires next to bushing, and pull into hole with wires.

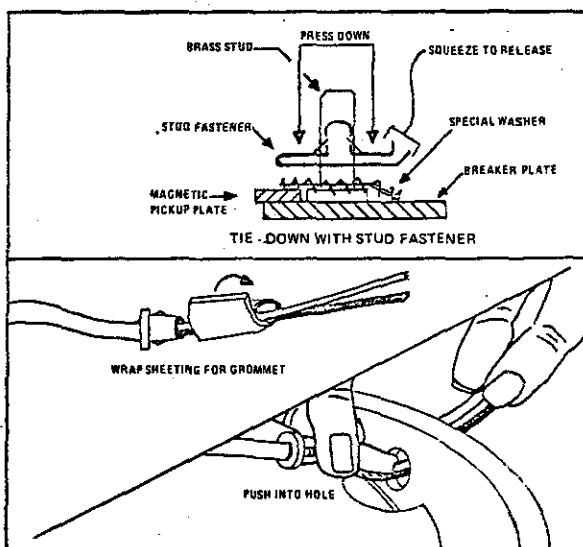
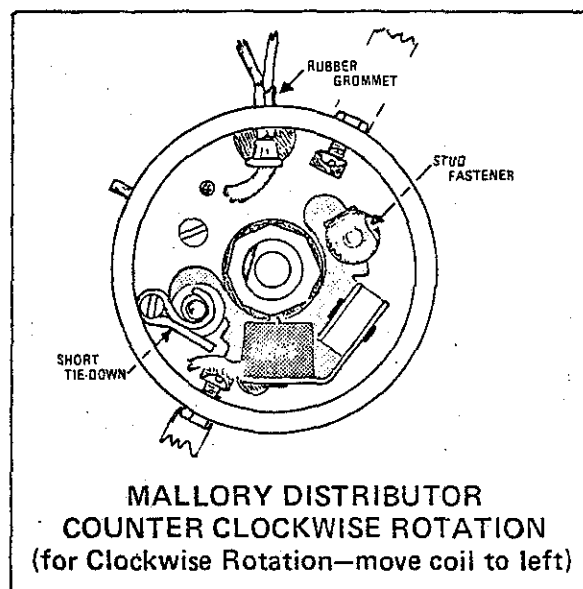

- Place coil wire terminals into plastic cover—be sure to place RED wire terminal in "V" side of plastic cover.

Push in pins until seated. The pins can be released from the plastic cover by squeezing in latches on terminals with a tweezer and pulling on wires.

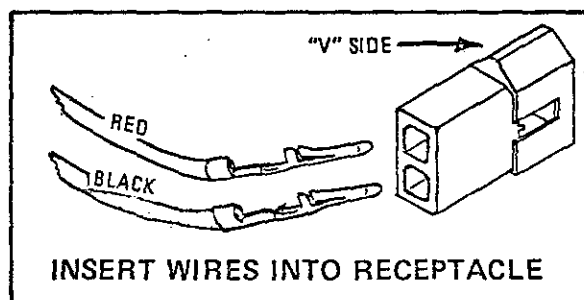

- Install Amplifier Module; remove resistor wire plug from cable plug near basic unit. Place E.D.M. Module wires into plug. Mount E.D.M. in top of heat sink.

Route Grey cable to distributor. Carefully route and fasten down this cable to prevent damage by cutting at sharp edges or burning on engine block or manifold. Plug Grey cable connector into receptacle from Magnetic Pick-Up Unit.

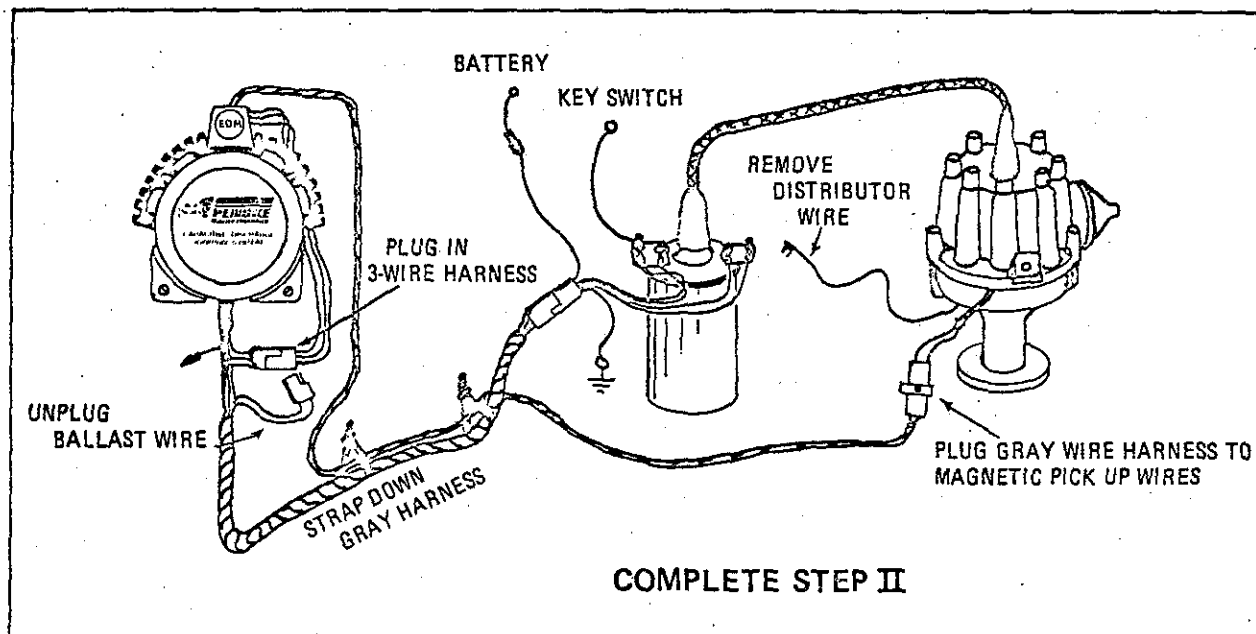
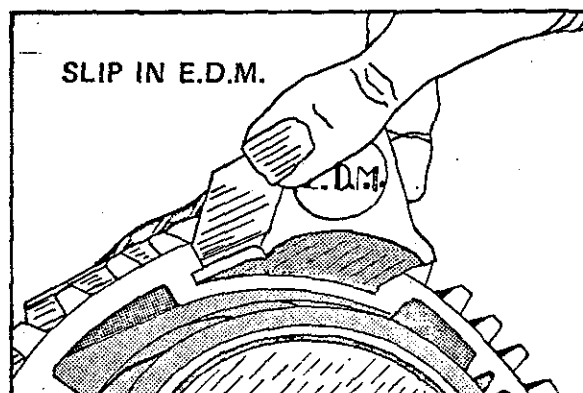

- Replace rotor and distributor cap. Be sure Magnetic Pick-Up wires do not touch rotor, or do not interfere with fit of cap.
- Start engine. Check timing with timing light (do not use neon timing light). Follow car manufacturer's instruction and set timing advance to that required. DO NOT over-advance timing from manufacturer's recommendation.



SYSTEMATICS, INC.

547 NORTH WHEELER STREET / SAINT PAUL, MINNESOTA 55104 / 612-645-5529

January 14, 1975

Mr. George Lew
California State Air Resources Board
9528 Telstar
El Monte, California 91731

Dear Mr. Lew:

I wish to thank you for the information you gave me in our phone conversation of January 9th. As a result we have tested the Carter Emission Reduction Kit on the bench and found that the enclosed recommended procedure does properly activate the speed sensing circuit.

We reviewed the compatibility problem with the Lana (Perfect Circle) people, both in California and in Indiana. Their recommendation was to have the user convert to the Vacuum Delay Valve if the unit was already equipped with the electronic switch. They indicated that the electronic approach was to be limited to the initial stocks in the field, and eventually would be a minor factor in the number of installations. The Vacuum approach does not need a signal from the ignition system.

However, the DANA people in Indiana indicated that they were preparing for their California dealers a set of instructions for dealer modification of the electronic speed switch to separate the power and tach signal so that it would be compatible with C.D. ignition. The instructions are now being printed. We discussed the recommendations they would make and prepared our insert accordingly.

Therefore, we are submitting the following format for instructions to be inserted on Page 10 of the Sears' OWNERS Manual for all units shipped to California.

We certify that the Sears' Penske Capacitive Discharge Ignition Unit (28.8205) will properly trigger the Carter Emission Reduction Kit when wired per these instructions. As the signal used (the TACH signal from the Amplifier Unit) is available in the same form for both the 28.8205 installation and for breakerless conversion with the 28.8206 Breakerless Conversion Kit, we certify the compatibility for both Sears' items.

As the Vacuum Delay Valve form of the DANA RETRONOX Kit does not use an ignition signal, no certification is required.

As the Electronic Speed Switch version of the DANA RETRONOX Kit is being ana-

Mr. George Low
Page 2

January 14, 1975

lyzed and proper recommendation being prepared by DANA, we can certify only that we produce a signal compatible with their indicated requirements when wired as shown in their instructions and by the enclosed instructions.

Please contact us if changes are required in the enclosed insert.

Sincerely,

SYSTEMATICS, Inc.

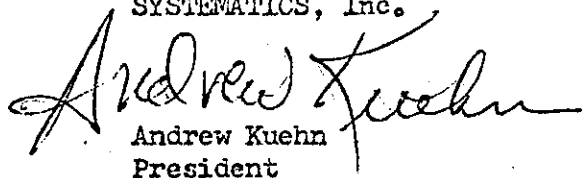

Andrew Kuehn
President

AK/dhm

Enclosure: Form No. 101 018, 1-13-75.

cc-Mr. C. Hattersley, Los Angeles

ALL CARS 1966 to 1970:

CARTER EMISSION REDUCTION KIT:

Wire as follows:

1. Route kit GREEN lead wire (for Negative side of coil) to Ignition Amplifier.
2. Attach to TACH connection (Black Wire Stub) with a 1/4" male Faston terminal (supplied). (See illustration ELECTRONIC TACHOMETER on P. 20.)

DANA RETRONOX KIT:

1. Kit with VACUUM DELAY VALVE (52B0198), no additional wiring is necessary. When retrofitting with a Dana RETRONOX system, ask for the system with the VACUUM DELAY VALVE.
2. Kit with ELECTRONIC SPEED SENSOR, where possible, replace Electronic Speed Sensor with Vacuum Delay Valve (Part No. 52B0198 - available from Dana dealer).

NOTE: If your engine requires the Electronic Speed Sensor due to limitations in vacuum porting, have DANA dealer modify the Electronic Speed Switch assembly per Dana instructions; wire original wire for coil to the Orange wire screw of Retainer at coil; wire added tach signal wire to TACH terminal at the Ignition Amplifier (do NOT wire to COIL + as noted in the Dana instructions).

Form No. 101 018
1-13-75

STEP I—CAPACITIVE DISCHARGE IGNITION UNIT—MODEL No. 243-8205

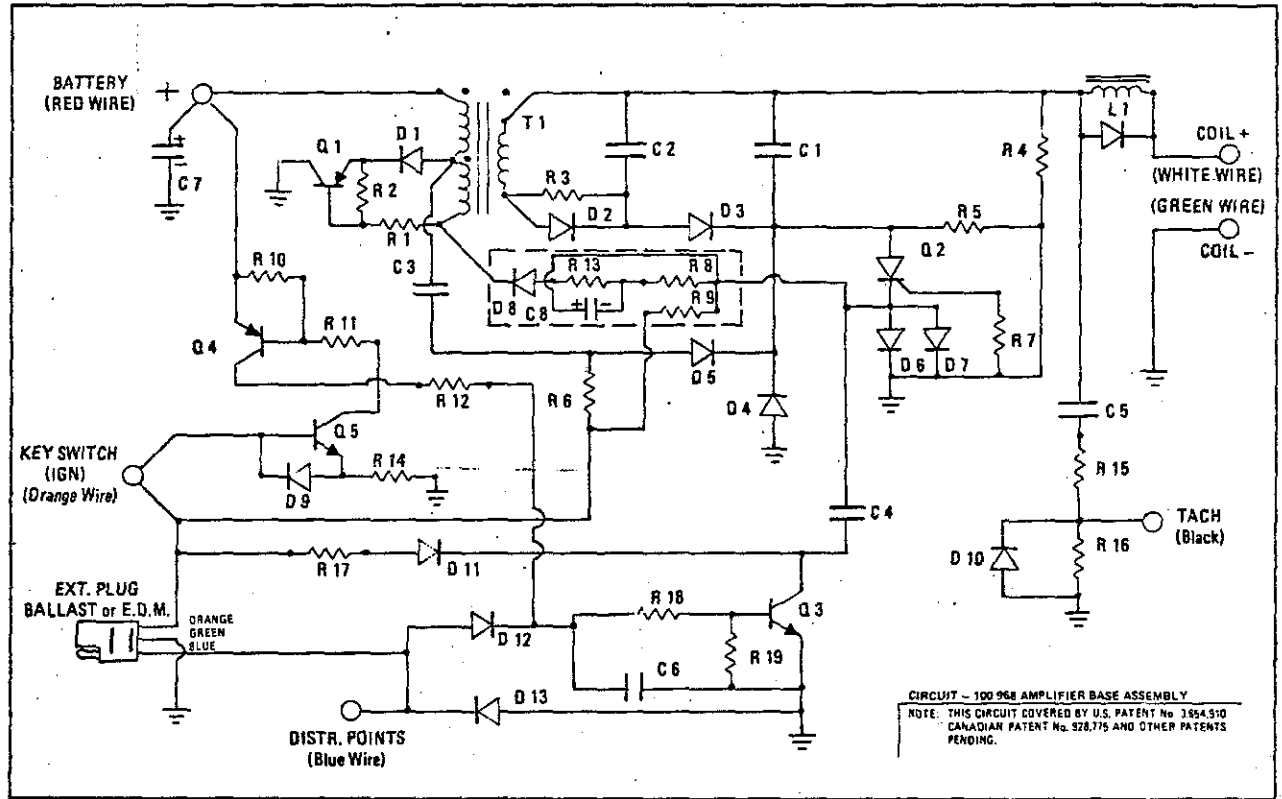

Key No.	Part No.	Description	Key No.	Part No.	Description
T 1	100 858-X	TRANSFORMER (Selected) *	R 5	100 143-6.8M	RESISTOR - 6.8 meg ohm 1/2 W - 10%
Q 1	100 708-X	TRANSISTOR (Selected) *	R 6	100 143-2.2K	RESISTOR - 2.2K ohm 1/2 W - 10%
Q 2	100 900	SCR ASSEMBLY	R 7	100 143-33	RESISTOR - 33 ohm 1/2 W - 10%
Q 3	100 937-1	TRANSISTOR - NPN	R 8	100 143-680	RESISTOR - 680 ohm 1/2 W - 10%
Q r	100 754	TRANSISTOR - PNP	R 9	100 143-4.7K	RESISTOR - 4.7K ohm 1/2 W - 10%
Q 5	100 937-2	TRANSISTOR - NPN	R 10	100 143-1.5K	RESISTOR - 1.5K ohm 1/2 W - 10%
R 1	100 650-X	RESISTOR - 15 W - (Selected) *	R 11	100 143-10K	RESISTOR - 10K ohm - 1/2 W - 10%
D 1	100 844	RECTIFIER - 18A - 50 PIV	R 12	100 143-1K	RESISTOR - 1K ohm 1/2 W - 10%
D 2 - D 5	100 590-1	DIODE - 1 a 750 PIV	R 13	100 143-100	RESISTOR - 100 ohm 1/2 W - 10%
D 6 - D 13	100 590-2	DIODE - 1 a 400 PIV	R 14	100 143-470	RESISTOR - 470 ohm - 1/2 W - 10%
C 1	100 985	CAPACITOR - 1.25 uf - 400V - 10%	R 15	100 143-100	RESISTOR - 100 ohm - 1/2 W - 10%
C 2	100 712	CAPACITOR - .05 uf - 400V - 10%	R 16	100 143-10K	RESISTOR - 10K ohm 1/2 W - 10%
C 3	100 810	CAPACITOR - .33 uf - 100V - 10%	R 17	100 143-330	RESISTOR - 330 ohm 1/2 W - 10%
C 4, C 6	100 711	CAPACITOR - .22 uf - 100V - 10%	R 18	100 143-1.5K	RESISTOR - 1.5K ohm 1/2 W - 10%
C 5	100 827	CAPACITOR - .01 uf - 1000V	R 19	100 143-470	RESISTOR - 470 ohm 1/2 W - 10%
C 7	100 870	CAPACITOR - ELECTROLYTIC 100 uf - 50V	L 1	100 962	INDUCTOR ASSEMBLY
C 8	100 963	CAPACITOR - TANTALUM - 4.7 uf - 10 V - 20%			
R 2	100 143-10	RESISTOR - 10 ohm 1/2 W - 10%			
R 3	100 143-18K	RESISTOR - 18K ohm 1/2 W - 10%			
R 4	100 143-10K	RESISTOR - 10K ohm 1/2 W - 10%			

*GIVE SERIAL NUMBER ON TRANSFORMER WHEN REPLACING ANY ONE OF THE SELECTED PARTS (T1, Q1, or R1).

REPAIR PARTS

STEP 1—CAPACITIVE DISCHARGE IGNITION UNIT—MODEL No. 243-8205

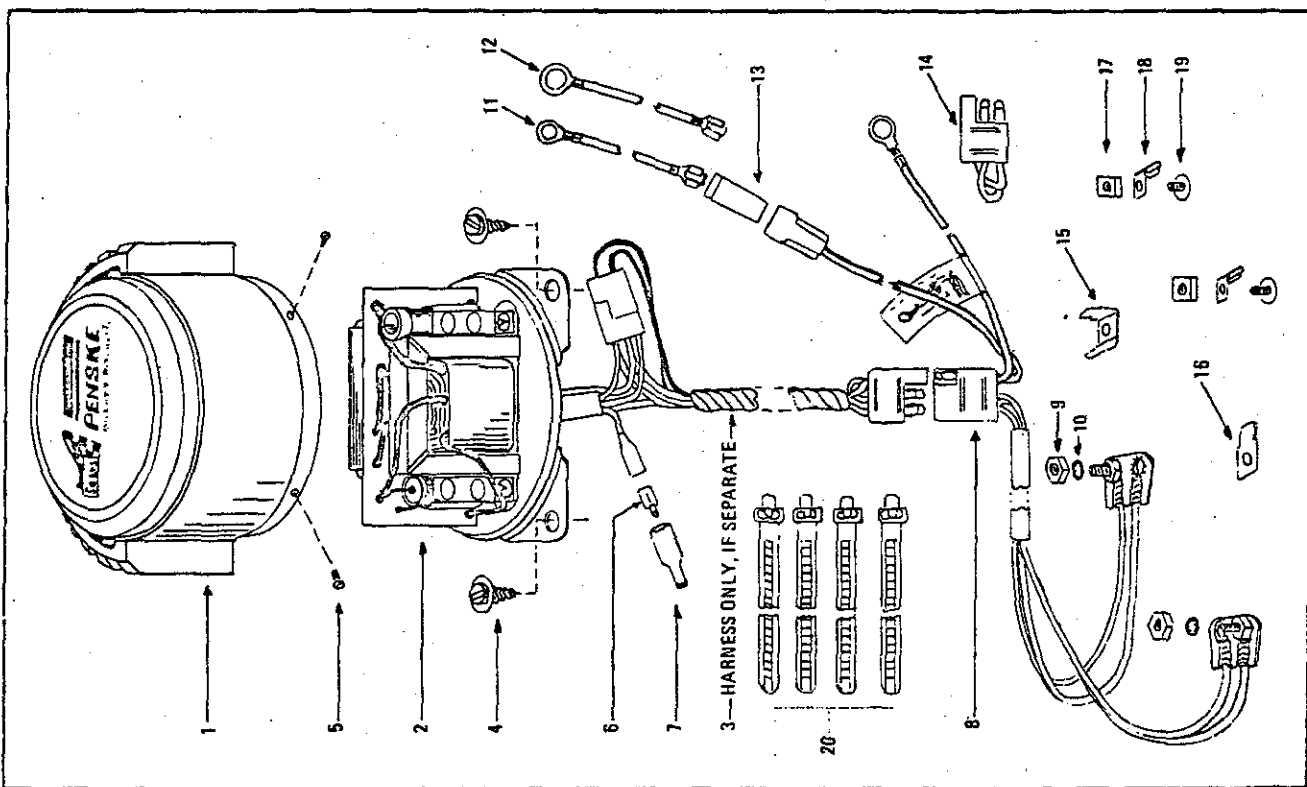
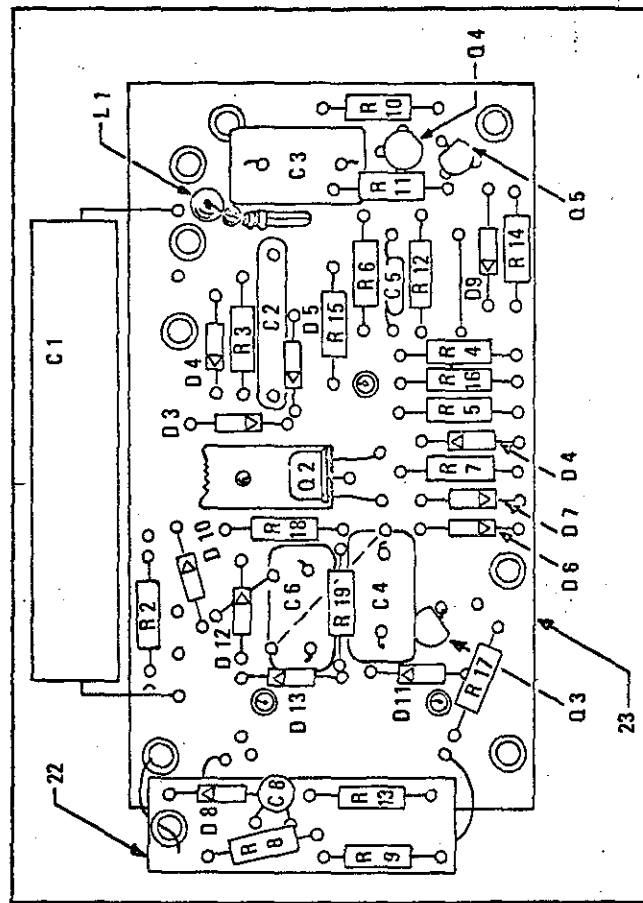
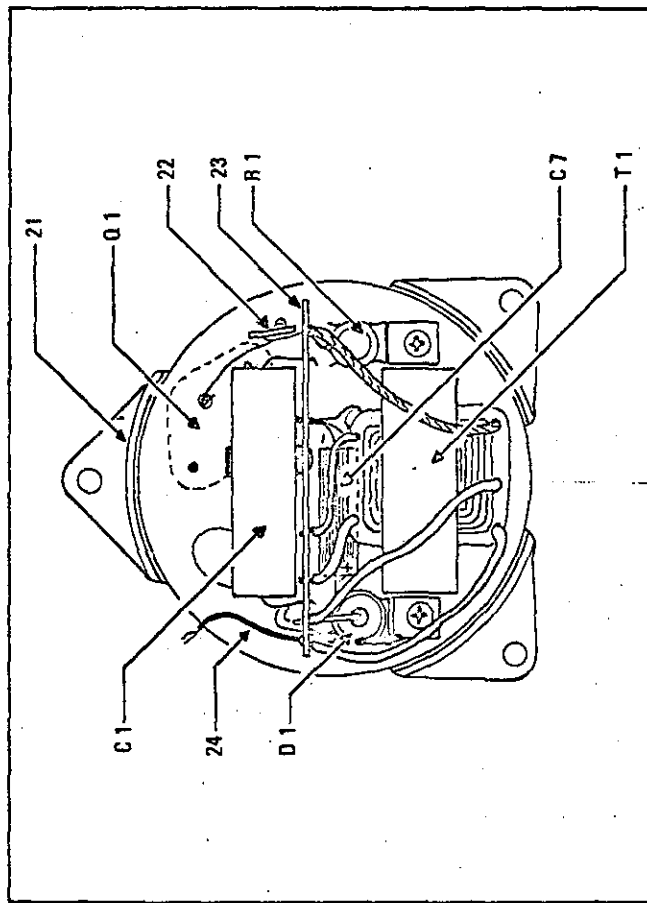

STEP I—CAPACITIVE DISCHARGE IGNITION UNIT—MODEL No. 243-8205

Key No.	Part No.	Description
1	100 911	COVER
2	100 968	BASE ASSEMBLY
3	100 944	UNIT HARNESS (if separate)
4	STD 611005	10 x 1/2 SELF TAP SCREW (3 required)
5	STD 600602	6-32 x 1/4 TAPPING SCREW (3 required)
6	100 530	BLADE TERMINAL — 1/4 MALE
7	100 522	TERMINAL COVER
8	100 817	COIL HARNESS
9	STD 541110	10-32 HEX NUT (2 required)
10	STD 551110	#10 LOCKWASHER (2 required)
11	100 818	SHORT HARNESS — 1/4" TERMINAL
12	100 819	SHORT HARNESS — LARGE TERMINAL
13	100834	TERMINAL COVER
14	100 821	JUMPER PLUG
15	100 841	MALE ADAPTER — double
16	100 836	MALE ADAPTER — single
17	STD 541106	6-32 NUT (2 required)
18	100 835	FEMALE ADAPTER (2 required)
19	STD 510603	6-32 x 3/8 SCREW (2 required)
20	100 959	CABLE TIE (4 required)
21	100 991	BASE PLATE UNIT
22	100 957	FEEDBACK CIRCUIT
23	100 961	POWER BOARD
24	100 782	FUSING WIRE (1.5 in. 24 AWG Insulated Wire)